

## Rooftop Air Conditioner

***Instruction Manual***

**Model:**

FACR13SA-PS/FACR13SA-BL  
FACR14SA-PS/FACR14SA-BL  
FACR15SA-PS/FACR15SA-BL

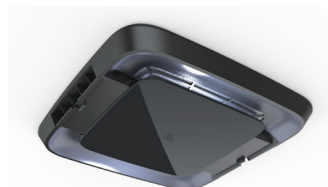

FACT12LA-PS/FACT12LA-BL  
FACT12SA-PS/FACT12SA-BL  
(Sold Separately)

Thank you for purchasing this Furrion® Chill™ Rooftop Air Conditioner. Before operating your new product, please read these instructions carefully. This will ensure safe use and reduce the risk of injury. This instruction manual contains information for installation, operation, maintenance of the product and safe use.

Please keep this instruction manual in a safe place for future reference. Be sure to pass on this manual to any new owners of this product.

The manufacturer does not accept responsibility for any damages due to not observing these instructions.

# Contents

<b>Contents</b> .....	<b>1</b>
<b>Important Safety Instructions</b> .....	<b>2</b>
Handling the Device .....	2
Handling Electrical Cables .....	3
<b>Before Installing</b> .....	<b>4</b>
What's in the Box .....	4
Choosing Proper Location for the Air Conditioner .....	4
Roof Preparation .....	6
Air Distribution Duct Sizing and Design .....	7
Air Distribution System Installation .....	8
Laying the Connecting Cables .....	9
<b>Installation</b> .....	<b>10</b>
Installing the Rooftop Unit .....	10
Installing the Wall Thermostat (model: FACW12SA-BL/FACW12PA-BL/FACW12ZA-BL, sold separately) .....	10
Installing the Air Distribution Box (for FACT12LA-PS/FACT12LA-BL/FACT12SA-PS/FACT12SA-BL models only, same for both ducted and non-ducted models, sold separately) .....	11
<b>Cleaning and Maintenance</b> .....	<b>16</b>
<b>Troubleshooting</b> .....	<b>17</b>
<b>Specifications</b> .....	<b>18</b>
<b>Wiring Diagram</b> .....	<b>19</b>
Multi Zone Wiring Diagram .....	20

# Important Safety Instructions

This manual has safety information and instructions to help users eliminate or reduce the risk of accidents and injuries. Please read this instruction manual carefully before installation and start-up, and store it in a safe place for future reference. If you pass on the device to another person, hand over this instruction manual along with it.

- The manufacturer accepts no liability for damage in the following cases:
  - Faulty assembly or connection
  - Damage to the product resulting from mechanical influences and excess voltage
  - Alterations to the product without express permission from the manufacturer
  - Use for purposes other than those described in the operating manual
- The following basic safety information should be heeded when using electrical devices to protect against:
  - Electric shock
  - Fire hazards
  - Injury
- All Furrion product referenced in this manual is to be installed in accordance with local and national codes, including the latest editions of the following standards:

## USA:

- NFPA 1192
- NFPA 70

## Canada:

- C22.1
- CSA Z240

## Handling the Device

### **WARNING**

- Installation and repair of the rooftop air conditioner must only be carried out by qualified personnel who are familiar with the risks involved and the relevant regulations. Inadequate repairs may cause serious hazards.
- Electrical devices are not toys. Keep electrical devices out of reach of children or elderly persons. Do not allow them to use electrical devices without supervision.
- Prevent inexperienced people from using the device without supervision.
- Do not undo the upper cover of the rooftop air conditioner in the event of a fire. Use approved extinguishing agents instead. Do not use water to extinguish fires.

## **⚠ CAUTION**

- The rooftop air conditioner must be installed securely so that it cannot fall down.
- Only operate the rooftop air conditioner if you are certain that the housing and the cables are not damaged.
- Do not use the rooftop air conditioner near flammable fluids or in closed rooms.
- Make sure no combustible objects are stored or installed near the air outlet. A distance of at least 20" must be kept.
- Do not reach into air outlets or insert any foreign objects into the device.

- Only use the device as intended.
- Do not make any alterations or conversions to the device.
- If faults occur in the refrigerant circuit, the system must be checked by a certified service technician and repaired properly. The refrigerant must never be released into the air.

## **Handling Electrical Cables**

### **⚠ WARNING**

The electrical power supply must only be connected by a qualified electrician.

### **⚠ CAUTION**

- Refer to NEC (National Electric Code) for proper sizing of wire gauge (awg) based on cable length and overcurrent protection rating that is supplying power to the air conditioner.
  - See rooftop unit nameplate for proper overcurrent protection sizing.
  - Attach and lay the cables so that they cannot be tripped over or damaged.
- 
- Only a qualified electrician should connect the rooftop air conditioner to electrical power.
  - Do not lay loose or bent cables next to electrically conductive materials.
  - Do not pull on the cables.
  - Use cable ducts to lay cables through walls with sharp edges.
  - Refer to rooftop unit nameplate and NEC for proper power supply rating.

# Before Installing

Read this installation manual completely before installing the rooftop air conditioner.

The following tips and instructions must be observed while installing the rooftop air conditioner.

## What's in the Box

Open the box and remove the components from carton. Make sure you have all the following items included in the packaging, if any item is missing, contact your dealer.

### Rooftop Air Conditioner:

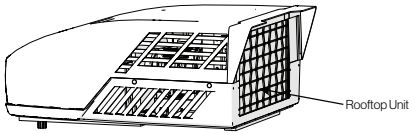

- Rooftop unit x 1
- Warranty Leaflet x 1

### Air Distributor Box (sold separately):

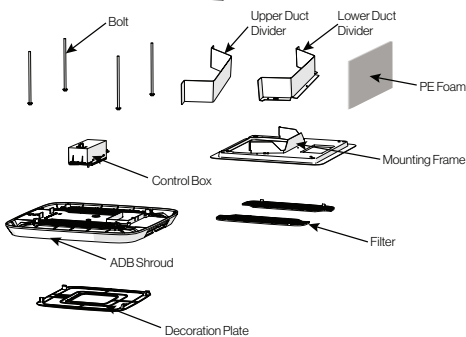

- Upper Duct Divider x 1
- Lower Duct Divider x 1
- Bolt x 4
- Mounting Frame x 1
- Control Box (sold separately) x 1
- Air Distribution Box (ADB) Shroud x 1

- Filter x 2
- Decoration Plate x 1
- Self-tapping Screws x 6
- PE foam x 1
- Instruction Manual x 1

## Choosing Proper Location for the Air Conditioner

**IMPORTANT:** The roof must be designed to support the weight of the rooftop unit and the weight of 2 installers standing on the roof.

There are two ways of installing the rooftop air conditioner:

- Using the existing roof vent opening in the vehicle roof.
- Making a new opening. In this case the opening should be reinforced by an appropriate frame as required.

## Existing Roof Vent Opening

The air conditioner is designed to fit over an existing 14" roof vent opening.

## New Opening

When no roof vent is available or another location is desired, the following is recommended:

- For one unit installation - the air conditioner should be mounted slightly forward of center (front to back) and centered from side to side.
- For two unit installations, install one air conditioner one third from the front of the RV and the other air conditioner two thirds from the front of the RV, aligned in the center.

It is preferred that the air conditioner be installed on a relatively flat and horizontal roof section measured when the RV is parked on a level surface.

**NOTE:** A 15° slant to either side or front to back is acceptable for all units. If the roof exceeds 15° please use an exterior leveling shim to make air conditioner level.

## After the Location Has Been Selected:

- Check for obstructions in the area where the air conditioner will be installed.

- Check the inside of the RV for return air kit obstructions. (i.e. door openings, room dividers, curtains, ceiling fixtures, etc.) Allow 6" (152mm) space from the opening to account for any potential return air kit obstructions.

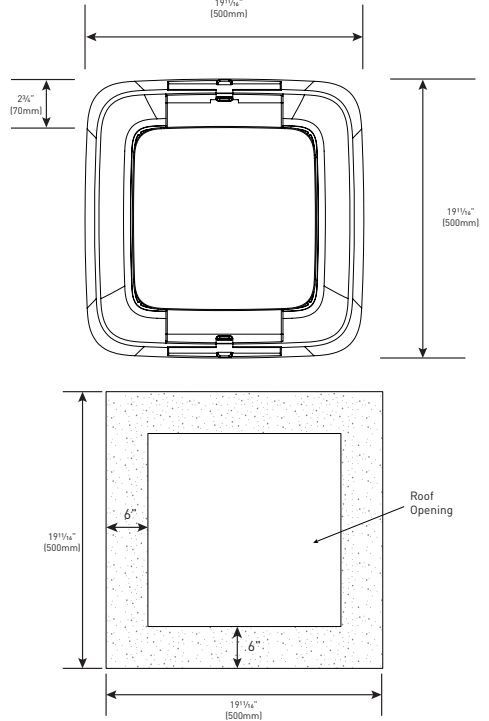
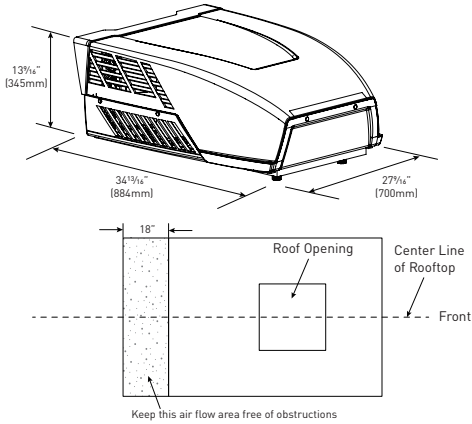

# Roof Preparation

Opening Requirements - Before preparing the ceiling opening, decide on the type of system options. Read all of the following instructions before beginning the installation.

## **⚠ WARNING**

### **Fire/Electric Shock Hazard**

- Make sure there are no obstacles inside the RV roof, floor and walls, such as wires and pipes.
- Shut off the gas supply and disconnect the 115VAC power from the RV before drilling or cutting into the RV. Failure to obey these warnings could result in death or serious injury.

## Roof Thickness

The installation of air conditioner suits for roof thickness from 3" (75mm) to 6" (152mm). For other thickness, please contact Furrion or Furrion authorized service agent.

## Installing in an Existing Opening

1. Unscrew and remove the roof vent.
2. Remove all caulking compound around the opening.
3. If the opening exceeds 14 $\frac{1}{4}$ " x 14 $\frac{1}{4}$ " (+ $\frac{1}{2}$ " ), it will be necessary to resize the opening to 14 $\frac{1}{4}$ " x 14 $\frac{1}{4}$ " (+ $\frac{1}{2}$ " ). If the opening is less than 14 $\frac{1}{4}$ " x 14 $\frac{1}{4}$ " (+ $\frac{1}{2}$ " ), it must be enlarged.

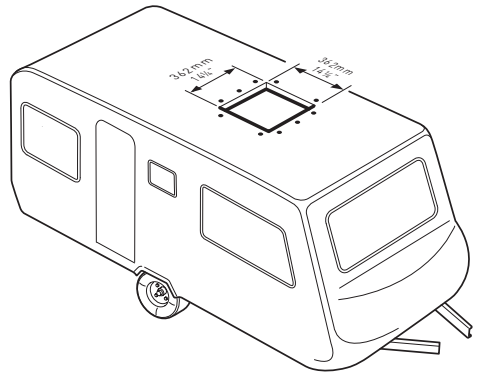

## Making a New Opening

If a roof vent opening will not be used, a 14 $\frac{1}{4}$ " x 14 $\frac{1}{4}$ " (+ $\frac{1}{2}$ " ) (362mm x 362mm) opening must be cut through the roof and ceiling of the RV. This opening must be located between the roof reinforcing members.

The 14 $\frac{1}{4}$ " x 14 $\frac{1}{4}$ " (+ $\frac{1}{2}$ " ) opening is part of the return air system of the air conditioner and must be finished in accordance with NFPA Standard 501C Section 2.7.2.

1. Mark a 14 $\frac{1}{4}$ " x 14 $\frac{1}{4}$ " (+ $\frac{1}{2}$ " ) square on the roof and carefully cut an opening.

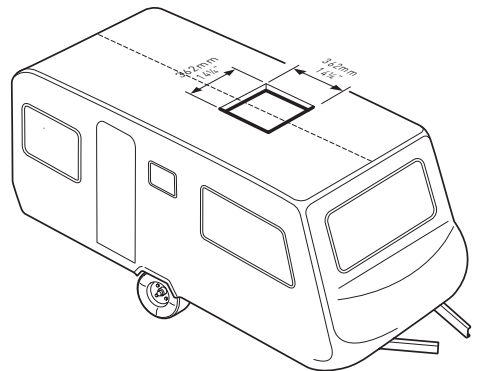

- Using the roof opening as a guide, cut a matching hole in the ceiling.  
**NOTE:** Maintain structural integrity. Otherwise damage to product and/or RV could occur. Always observe the following guidelines while structuring the opening.

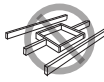

Do not cut roof structure or rafters

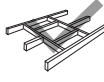

Good: rafters supported by cross beams

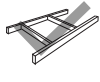

Good: location between roof rafters

- The opening created must be framed to provide adequate support and prevent air from being drawn from the roof cavity.
- Lumber  $\frac{3}{4}$ " or more in thickness must be used. Remember to provide an entrance hole for power supplies, wall thermostat and furnace wiring for connections. Leave 15" (381mm) minimum at the front of the opening.

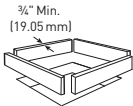

$\frac{3}{4}$ " Min.  
(19.05 mm)

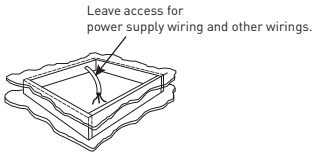

Leave access for power supply wiring and other wirings.

## Air Distribution Duct Sizing and Design

The installer of this system must design the air distribution system for their particular application.

**NOTE:** Make sure ductwork will NOT bend or collapse during and after installation, and that it is correctly insulated and sealed. Otherwise, damage to roof structure and ceiling could occur. The following requirements must be met for properly operate the unit:

Roof Cavity Depth	3"-6" (75mm-152mm)	
Duct Cross Sectional Area	21 Sq. In. Min.	
Duct Size	Depth	1½" Min. - 2½" Max. (38mm Min. - 63.5mm Max.)
	Width	7" Min. - 10" Max. (178mm Min. - 254mm Max.)
	Total Duct Length	15Ft. Min. - 40Ft. Max. (4.5m - 13m)
	Duct Length (short run)	½ Total Duct Length
Register Requirements per A/C Unit	Number Required	4 Min. - 8 Max.
	Supply Register Free Air Area	14 Sq. In. (90 sq. cm)
	Return Register Free Air Area	40 Sq. In. (258 sq. cm)
	Distance From Duct End	5" Min. - 8" Max. (127mm Min. - 203mm Max.)
	Distance From Elbow	15" (381mm)
Total System Static Air Pressure	Blower at High Speed, Filter & Grille In Place	0.55 - 1.10 In. W.C.

- Properly insulate and seal all discharge air ducts to prevent condensation from forming on their surfaces or adjacent surfaces during operation of the unit. This insulation must be R-7 minimum.



TOP VIEW  
(BACK OF RV)

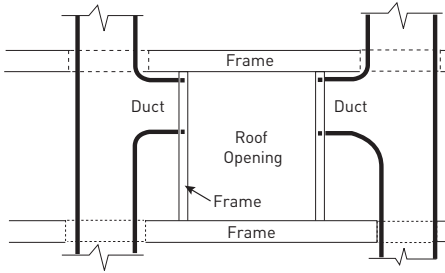

SIDE VIEW  
(TOWARD BACK OF RV)

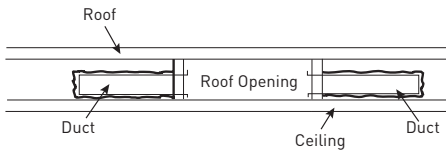

- Return air openings must have 80 square inches (516 square centimeters) minimum free area including the filter.
- Return air to the unit must be filtered to prevent dirt accumulation on the unit cooling surface.

## Air Distribution System Installation

It is the responsibility of the installer to review each RV floor plan to determine the following items in conjunction with "Air Distribution Duct Sizing and Design" section on Page 8.

**NOTE:** Alternate configurations and methods may be used which will allow the unit to operate properly, however, these alternate configurations and methods **MUST** be approved by Furrion in writing.

- Duct size
- Duct layout
- Register size
- Register location
- Thermostat location
- Indoor temperature sensor location (if applicable)

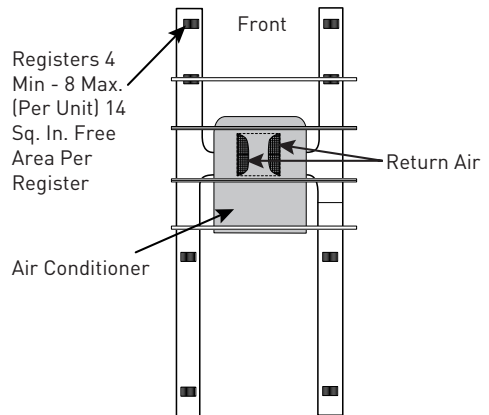

# Laying the Connecting Cables

The rooftop air conditioner must be connected to an electric circuit which is able to supply the required power supply (see chapter "Specification").

**NOTE:** The supply wire must be located in the front portion of the roof opening. The power supply must be equipped with a time delay fuse or circuit breaker. See rooftop unit nameplate for rating.

## DANGER

### Electrical Shock Hazard

- Disconnect power before servicing. Failure to obey this warning could result in death or serious injury.
- Provide grounding in compliance with all applicable electrical codes. Failure to obey this warning could result in death or serious injury.

1. Refer to the applicable electric code guidelines for sizing the appropriate wire gauge, length and type.
2. Route a 115VAC supply wire with ground wire from the time delay fuse or circuit breaker box to the roof opening.  
**NOTE:** Refer to rooftop unit nameplate and applicable code for proper installation.
3. Use approved method to protect the wire where it passes through the opening.
4. Feed the 115VAC cable through the opening into the vehicle interior. Make sure at least 15" (381mm) of supply wire extends into the roof opening. This ensures an easy connection at the control box.

# Installation

## Installing the Rooftop Unit

### **⚠ CAUTION**

- The rooftop unit weighs approximately 100 pounds (45 kg). To prevent back injury, use a mechanical hoist when lifting or moving the unit. Failure to obey this warning could result in injury.
- Do not slide unit. It may damage the gasket at the bottom of the rooftop unit and cause leakage.
- Do not grasp the ventilation slots to lift the rooftop unit up.

1. Grasp the bottom of two sides of the unit, lift and position the rooftop unit into the prepared opening using the gasket at the bottom of the rooftop unit as a guide. (Fig. 1)

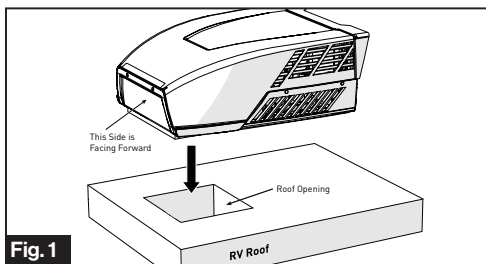

This completes the outside installation of the rooftop unit. Minor adjustments can be done from inside of the RV if required.

## Installing the Wall Thermostat (model: FACW12SA-BL/ FACW12PA-BL/ FACW12ZA-BL, sold separately)

There are 3 types of wall thermostat for you to select.

- FACW12SA-BL: Single zone basic wall thermostat
- FACW12PA-BL: Single zone premium wall thermostat
- FACW12ZA-BL: Multi zone wall thermostat

Based on the wall thermostat version you selected. Please refer to the separate instruction manual on how to install the wall thermostat to the RV.

# Installing the Air Distribution Box (for FACT12LA-PS/FACT12LA-BL/FACT12SA-PS/FACT12SA-BL models only, same for both ducted and non-ducted models, sold separately)

The rooftop unit is fixed on the RV roof using 4 long bolts through the mounting frame from the interior of the RV ceiling.

1. Check the gasket alignment of the rooftop unit inside the RV over the roof opening and adjust as necessary by lifting and moving slightly. (Fig. 2)

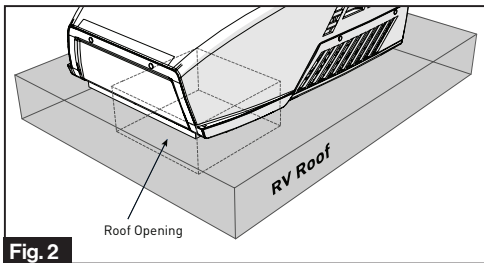

**Fig. 2**

2. Reach up into the return air opening and pull the rooftop unit electric cord, 115VAC power cord, ±12VDC and thermostat wires. (Fig. 3)

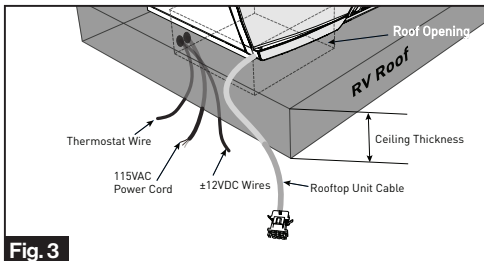

**Fig. 3**

3. Install the assembled mounting frame and the lower duct divider into the rooftop opening. Make sure the "THIS WAY FRONT" mark is facing front (the direction of the vehicle) while installing. (Fig. 4)

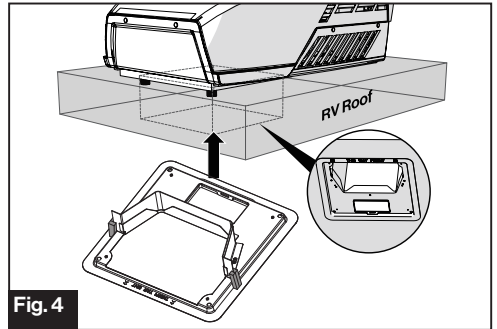

**Fig. 4**

4. Fix the assembled mounting frame and lower duct divider into the rooftop unit using 4 bolts provided. (Fig. 5)

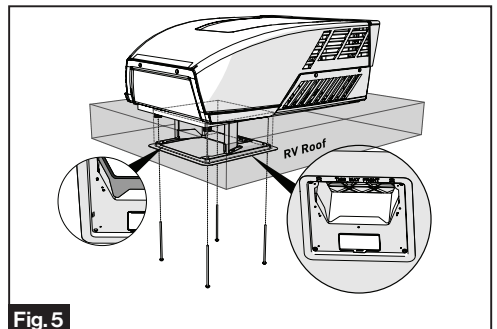

**Fig. 5**

**NOTE:** If bolts are left loose there may not be an adequate roof seal or if over tightened, damage may occur to the rooftop base or mounting frame. Evenly tighten the four bolts to a torque of 40 to 50 inch pounds. This will compress the roof gasket to approximately  $\frac{1}{16}$ ".

- Pull to remove the film off the double sided sticky tape on the inner side of the lower duct divider. (Fig. 6)

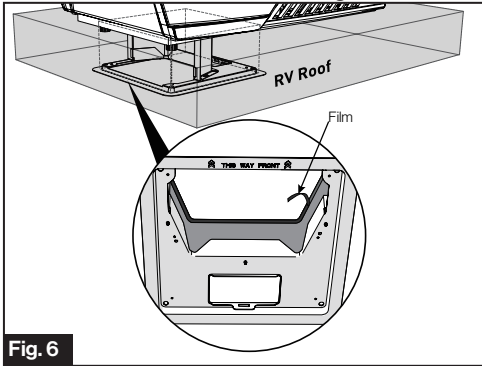

Fig. 6

- Stick the upper duct divider into the assembled mounting frame.  
**NOTE:** Make sure the upper duct divider is compressing the top foam on the base of the unit, and compress to doubled sided tape on the lower duct divider to ensure a positive retention. (Fig. 7)

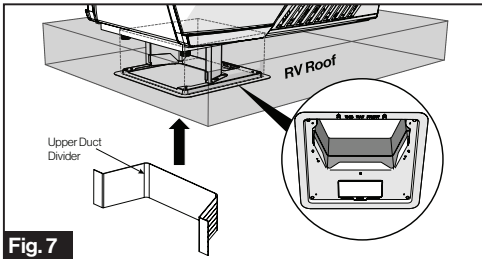

Fig. 7

- Peel to remove the release paper from the PE foam, overlap the sticky side over all gaps and compress to seal and insulate the entire section. (Fig. 8)

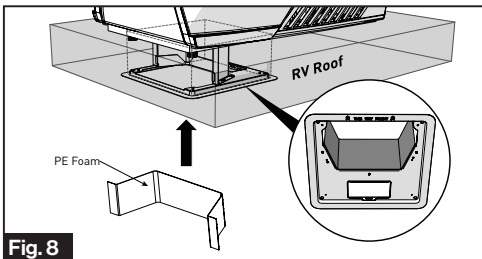

Fig. 8

- Use self adhesive foil tape to seal all remaining gaps around the duct divider, PE foam and roof opening, completely sealing duct edges as required.
- Remove the cable compartment cover using a Phillips screw driver. (Fig. 9)

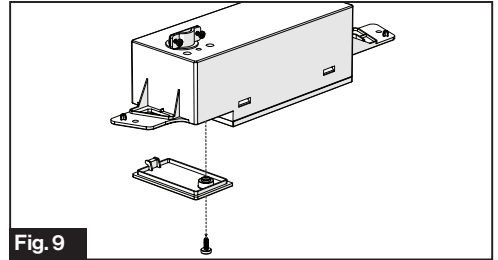

Fig. 9

## ⚠ DANGER

### Electrical Shock Hazard

- Disconnect power before servicing. Failure to obey this warning could result in death or serious injury.
- Provide grounding in compliance with all applicable electrical codes. Failure to obey this warning could result in death or serious injury.

10. Loosen the strain relief on top of the control box and let the 115VAC power cord pass through. (Fig. 10)

**NOTE:** Always follow the color code while connecting the cables.

Black - Hot

White - Neutral

Green/yellow - Ground

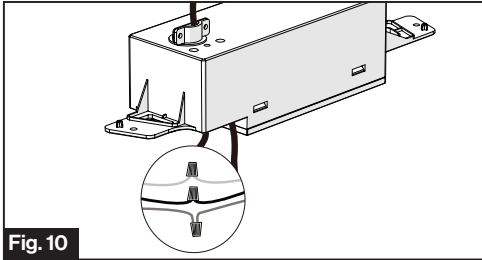

Fig. 10

11. Tighten the cable clip until the cable is properly restrained.

**NOTE:** Do not over tighten.

12. Fit all cables into the cable compartment and tuck any excess wires up out of the way. Tighten the cover with screw. (Fig. 11)

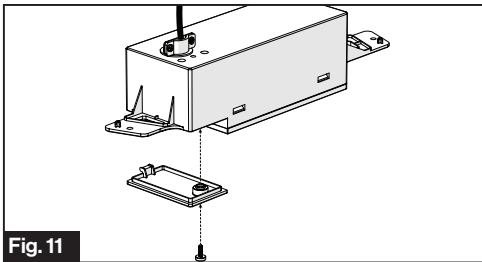

Fig. 11

13. Lock the freeze sensor onto the pipe of the evaporator. Connect the freeze sensor cable of the control box to the freeze sensor of the rooftop. (Fig. 12)

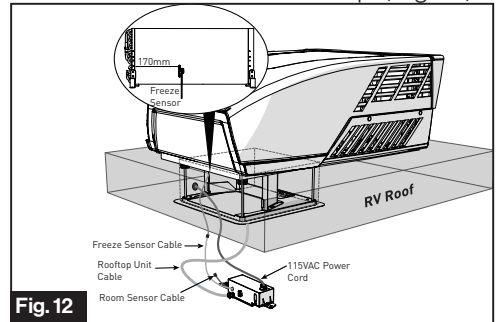

Fig. 12

14. Connect the other wires of the rooftop unit cable to the control box. (Fig. 13)

- **Furnace + / Furnace - Cable:** Connect to Furnace.
- **Analog Cable (if applicable):** Connect to external analog input.
- **LED Cable:** Connect to LED stripe.
- **Wall Thermostat Cable:** Connect to wall thermostat and another zone's control box if applicable. (See multi zone wiring diagram in page 21).
- **Rooftop Cable:** Connect to rooftop unit.
- **115VAC Power Cord:** Connect to 115VAC power source.

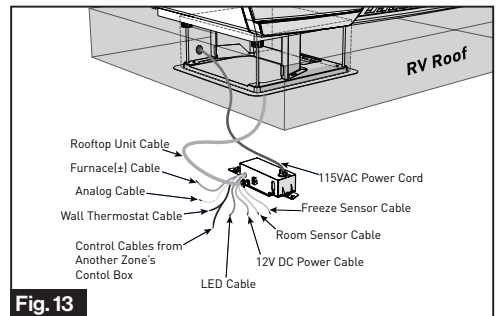
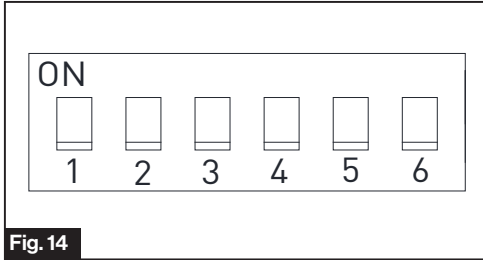

Fig. 13

15. Set up the control box dip switches as indicated in the illustration and table below (Fig. 14):



Zone Selection*	DIP 1 :DIP2	DIP 1	DIP 2	ZONE
		OFF	OFF	ZONE1
		OFF	ON	ZONE2
		ON	OFF	ZONE3
		ON	ON	ZONE4
Heat Pump (selected models)	DIP 3	Reserved		
Furnace	DIP 4	OFF	Furnace Off	
		ON	Furnace On	
Electric Heat (selected models)	DIP 5	OFF	Heat Stripe Off	
		ON	Heat Stripe On	
Analog / Digital	DIP 6	OFF	Digital	
		ON	Analog	

**\*NOTE:** DIP1 and DIP2 are for Multi Zone only.

16. Connect the wall thermostat cable and 12VDC power cable to the control box.(Fig. 15)

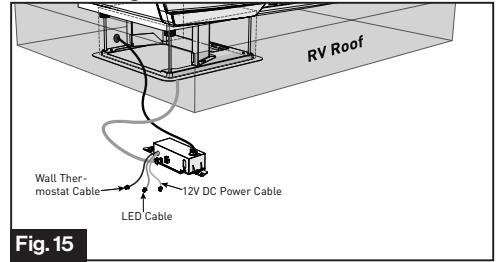

17. Install the control box into the mounting frame and fix with 2 self-tapping screws (one piece each side). (Fig. 16)

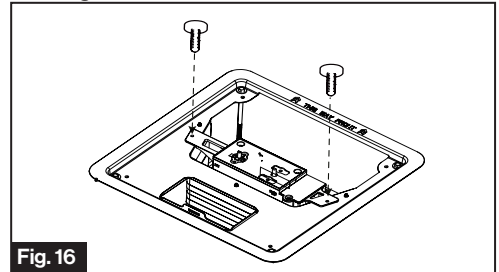

18. Connect the LED cable (if applicable) from the ADB shroud to the control box. (Fig. 17)

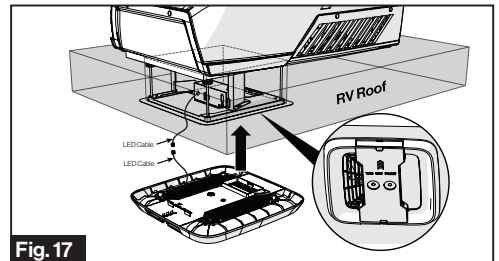

19. Install the Air Distribution Box (ADB) shroud over the mounting frame and fix with 4 self-tapping screws.

**NOTE:** Make sure the "THIS WAY FRONT" mark is facing front (the direction of the vehicle) while installing. (Fig. 18)

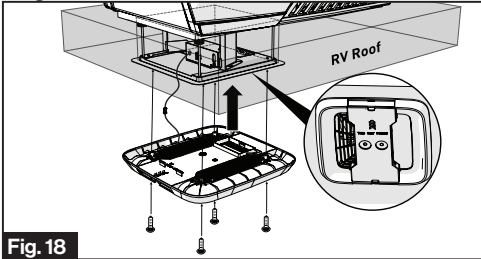

20. Align the filter tabs with mating notches and push to snap the filters into the ADB shroud. (Fig. 19)

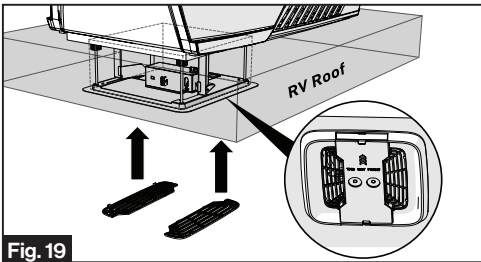

21. Align the decoration plate tabs with the mating notches on the ADB shroud and push to snap the decoration plate into place. (Fig. 20)

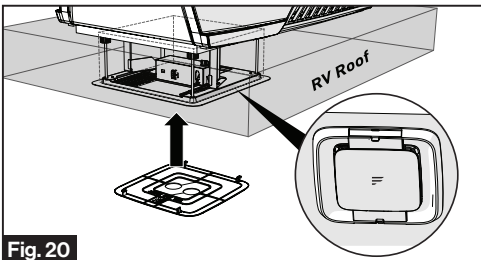

22. Your new rooftop air conditioner has now been fully installed in the RV roof. (Fig. 21)

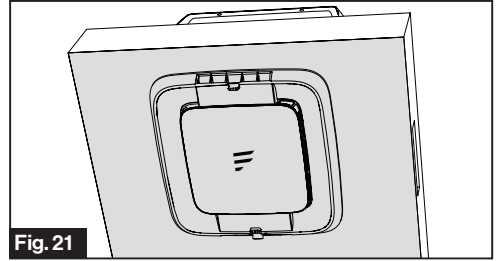

Based on the wall thermostat version you selected. Please refer to the separate instruction manual on how to operate your RV air conditioning system.



# Cleaning and Maintenance

A blocked filter will impair the cooling and heating performance of the unit significantly.

The filter must be cleaned periodically to ensure that it does not become clogged with dust and other particles. The state of the filter can be ascertained from its appearance. If it appears dirty or clogged then it should be cleaned.

## ⚠ WARNING

Airborne particles can pose a health risk, particularly to young children and the elderly. Ensure that filters are cleaned in a safe and well ventilated area.

## To Clean the Filter

The filter should be cleaned every four weeks or more when in use. Prolonged use, higher concentrations of airborne particles and various other factors may result in the filters needing to be cleaned more often.

1. Remove the decoration plate from the air conditioning system by pushing the side tabs to release. (Fig. 22)

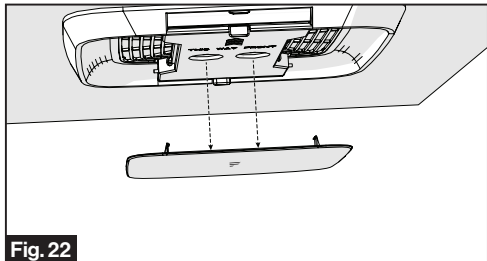

2. Remove the filters by pushing the tabs to release. (Fig. 23)

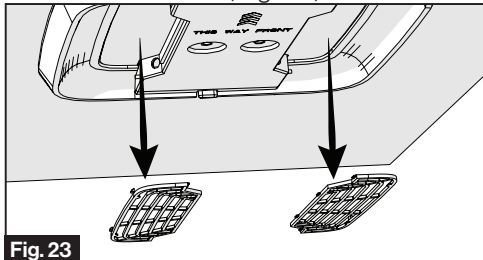

3. The filter can be washed with warm soapy water. Care must be taken to avoid ripping the fabric.
  4. Replace the filters and decoration plate, by reversing the above process.
- NOTE:** The filter must be completely dry before re-installation.

## To Replace the Filter

Filter changes should be carried out depending on the amount of use, it is recommended to change at least every 12 months. Never operate the air conditioning system without a filter, since this can decrease performance and indoor air quality.

Replacement return air filters can be ordered directly from Furrion.

# Troubleshooting

Problem	Cause	Remedy
Rooftop air conditioner Abnormal shutdown	Freeze sensor has tripped.	Outer temperature is too low or all air nozzles are closed.
Not cool enough	Refrigerant leakage	Contact an authorized service agent or Furrion (see the detail contact info at the back page of this manual).
	The rooftop air conditioner is not set to cooling.	Set the rooftop air conditioner to cooling.
	The set temperature is too high.	Select a lower temperature.
	The evaporator fan is damaged.	Contact an authorized service agent or Furrion (see the detail contact info at the back page of this manual).
	The condenser fan is damaged.	Contact an authorized service agent or Furrion (see the detail contact info at the back page of this manual).
	The air intake grilles are blocked or obstructed.	Remove any leaves and other dirt from the ventilation grilles of the rooftop air conditioner.
	The blower is defective.	Contact an authorized service agent or Furrion (see the detail contact info at the back page of this manual).
Water enters the vehicle	The condensation water drainage openings are clogged up.	Clean the drainage openings for condensation water.
	The seals are damaged.	Contact an authorized service agent or Furrion (see the detail contact info at the back page of this manual).
Rooftop air conditioner does not switch on	No supply voltage connected.	Check the power supply.
	The voltage is too low.	Contact an authorized service agent or Furrion (see the detail contact info at the back page of this manual).
	Fuse blown or circuit protector tripped.	Check the electrical fuse of the power supply.

# Specifications

## Specification

### PERFORMANCE

Model Number	FACR13SA-PS FACR13SA-BL	FACR14SA-PS FACR14SA-BL	FACR15SA-PS FACR15SA-BL
Cooling Capacity (Btu/h)	13,500	14,500	15,500
Dehumidification (pint/h)	2.5	2.7	3.2
Applicable vehicle length (feet)	23	26	31
Refrigerant	R410A	R410A	R410A
Charge (Oz)	15.9	19.8	23.1
Roof top Unit Dimensions (L x W x H) (inch)	34 $\frac{7}{8}$ x 27 $\frac{5}{8}$ x 13 $\frac{5}{8}$	34 $\frac{7}{8}$ x 27 $\frac{5}{8}$ x 13 $\frac{5}{8}$	34 $\frac{7}{8}$ x 27 $\frac{5}{8}$ x 13 $\frac{5}{8}$

### ELECTRICAL

Volts/Frequency	115V-/60Hz/1Ph	115V-/60Hz/1Ph	115V-/60Hz/1Ph
Power Watts (Cooling)	1450	1620	1720
Amps (Cooling)	13.1	14.6	15.4
Power Cord Gauge Min. (mm <sup>2</sup> )	AWG12	AWG12	AWG12

# Wiring Diagram

## ⚠ DANGER

### Electrical Shock Hazard

- Disconnect power before servicing. Failure to obey this warning could result in death or serious injury.
- Provide grounding in compliance with all applicable electrical codes. Failure to obey this warning could result in death or serious injury.

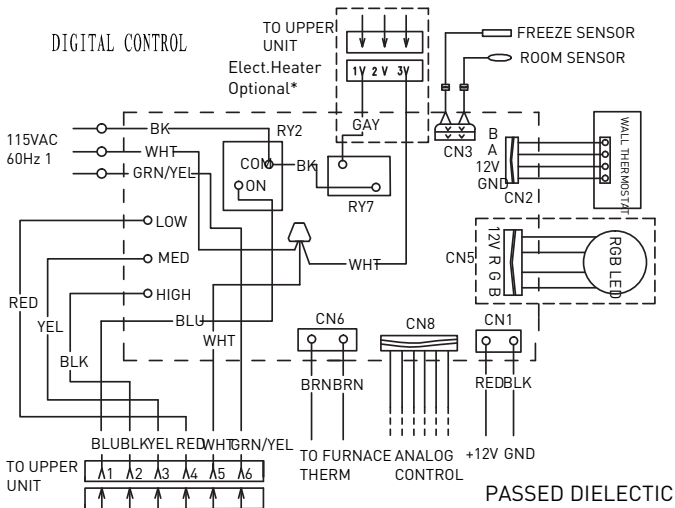
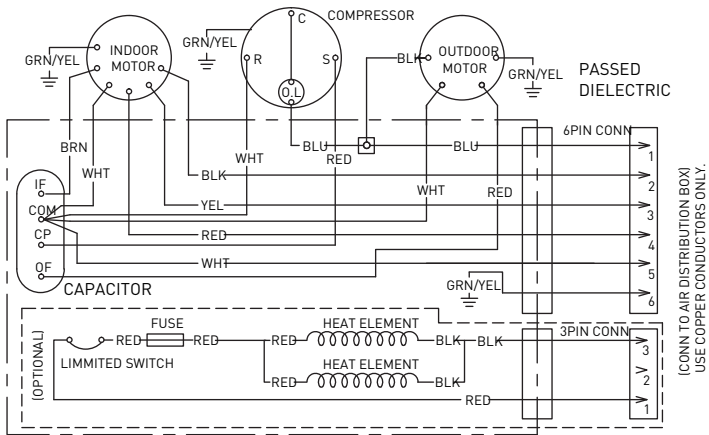

# Multi Zone Wiring Diagram

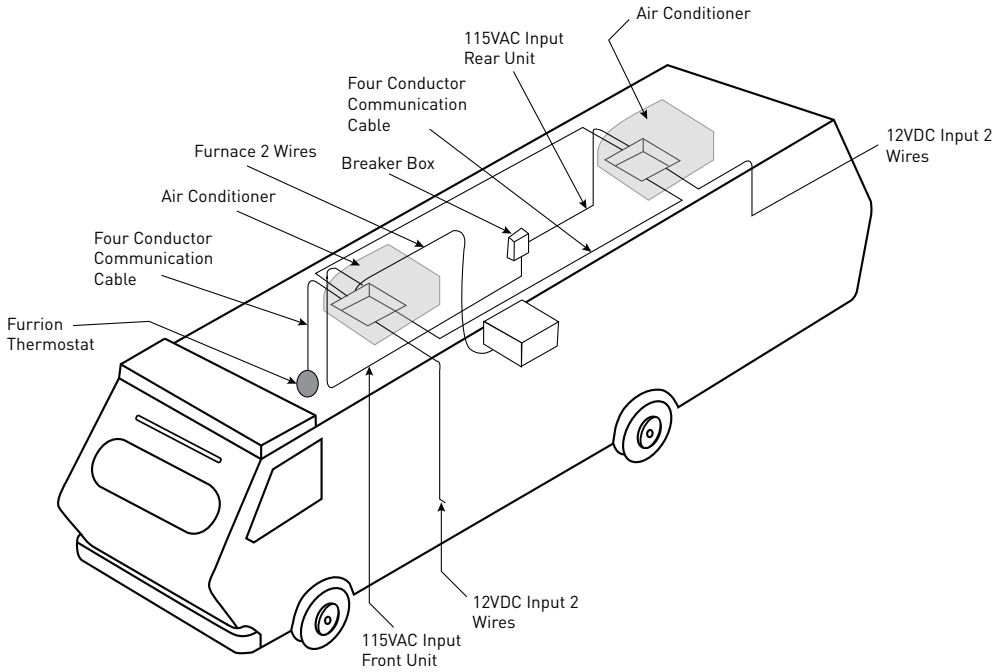







The contents of this manual are proprietary and copyright protected by Lippert. Lippert prohibits the copying or dissemination of portions of this manual unless prior written consent for an authorized Lippert representation has been provided.

Any unauthorized use shall void any applicable warranty. The information contained in this manual is subject to change without notice and at the sole discretion of Lippert. Revised editions are available for free download from [lippert.com](http://lippert.com).

Please recycle all obsolete materials.

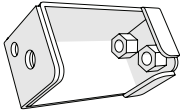
For all concerns or questions, please contact Lippert  
PhL 432-LIPPERT (432-547-7378) | Web: [lippert.com](http://lippert.com) |  
E-mail: [customerservice@lci1.com](mailto:customerservice@lci1.com)

## What's in the box

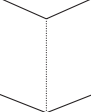
Component	Description	Quantity
	Conversion Bracket	4
	Bolt ST $\frac{1}{4}$ -20, 4 $\frac{3}{4}$ " (121mm) long	4
	Bolt ST $\frac{1}{4}$ -20, 2" (51mm) long	4
	Wire Adapter	1
	Installation Instructions	1

# FURRION

Furrion Innovation Center & Institute of Technology

©2007-2019 Furrion Ltd. Furrion® and the Furrion logo are trademarks licensed for use by Furrion Ltd. and registered in the U.S. and other countries.

FURRION.COM

IG-FHA00009 V1.0

The Scope of this manual is to support the installation of your new Furrion rooftop unit with your existing Air Distribution Box unit and control using the Furrion universal conversion kit.

## Installation

- Follow the Furrion rooftop installation instructions to prepare the RV roof opening and install the rooftop unit onto the RV roof. The recommended roof thickness is 3-6" (75-152mm).

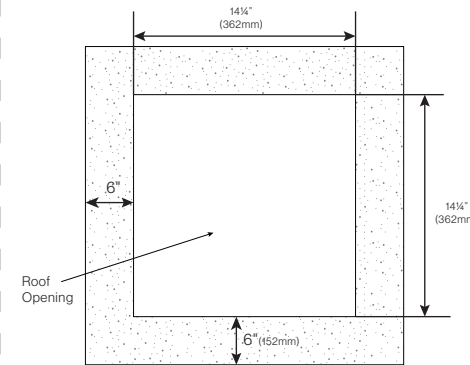

- Install the four conversion brackets onto the bottom of the rooftop unit as shown in Fig. 1 and fix with 4 short bolts provided.

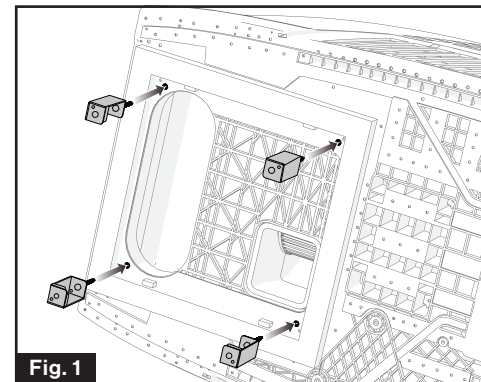

Fig. 1

- Replace existing metal bracket and duct divider, per existing installation requirements. Be sure to seal any gaps an openings with aluminum foil tape.
- In case you need to connect the Furrion rooftop to an other brand Air Distribution Box (ADB), Furrion provides a wire adapter in the conversion bracket packaging as an option. (Fig. 2) Always adjust the thermostat to the lowest temperature when the 'FAN' mode is selected.

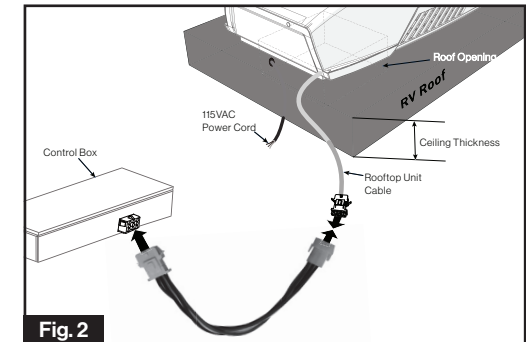

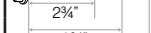
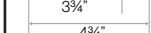

Fig. 2

- Refer to the existing trim kit installation manual to install the trim kit onto the RV roof and secure with the 4 long bolts provided. **NOTE:** Furrion provides 4 3/4" (121mm) bolts as default, refer to the table below to cut or buy new bolts from you local store when different length of bolts are required (manual version only).

ST $\frac{1}{4}$ -20	Length	Roof Thickness
	2 $\frac{1}{4}$ " (70mm)	3-4" (76-102mm)
	3 $\frac{3}{4}$ " (95mm)	4-5" (102-127mm)
	4 $\frac{3}{4}$ " (121mm)	5-6" (127-152mm)