



Tandem Axle 4-6K



Tandem Axle 5-8K

Equa-Flex®

Tandem Axle

Installation and

Owner's Manual

(For Aftermarket Applications)

Table of Contents

Introduction	2
Quick Facts	2
Safety	2
Parts List	3
Equa-Flex Tandem Axle 4-6K Aftermarket Kit	3
Equa-Flex Tandem Axle 5-8K Aftermarket Kit	3
Parts Available for Purchase	4
Resources Required	4
Prior to Installation	5
Installation	6
Notes	7

Equa-Flex Tandem Aftermarket Kits	
Part #	Description
2024114953	Equa-Flex; Tandem Axle; 4-6K
2024115051	Equa-Flex; Tandem Axle; 5-8K



Equa-Flex® Tandem Axle Installation and Owner's Manual (For Aftermarket Applications)

Introduction

The Equa-Flex Tandem Axle 4-6K kits are used for tandem-axle trailers with double-eye leaf springs and weight capacity from 3,000 to 6,000 lbs (1,361 to 2,722 kg). The Equa-Flex Tandem Axle 5-8K heavy-duty kit is for tandem-axle trailers with double-eye leaf springs and a weight capacity from 5,000 to 8,000 lbs (2,268 to 3,629 kg).

Quick Facts

- Comes with two Equa-Flex sub units and 2 Equa-Flex sub units with upper shock weldmounts.
- Each sub unit comes with pre-installed bronze bushings.
- Center hanger and other mounting hardware sold separately.

NOTE: Images used in this document are for reference only when assembling, installing and/or operating this product. Actual appearance of provided and/or purchased parts and assemblies may differ.

Additional information about this product can be obtained from lci1.com/support or by using the LippertNOW app. Replacement kits can be ordered from <https://store.lci1.com/> or by using the LippertNOW app.

The LippertNOW app is available for free on Apple App Store® for iPhone® and iPad® and also on Google Play™ for Android™ users.

App Store® and iPad® are registered trademarks of Apple Inc. Google Play™ and Android™ are trademarks of Google Inc.

For additional support on this product, scan this QR code or go to: <https://support.lci1.com/equa-flex>



Safety

Read and fully understand all instructions before installing or operating this product. Adhere to all safety labels.

This manual provides general instructions. Many variables can change the circumstances of the instructions, i.e., the degree of difficulty, operation and ability of the individual performing the instructions. This manual cannot begin to plot out instructions for every possibility, but provides the general instructions, as necessary, for effectively interfacing with the device, product or system.

Failure to correctly follow the provided instructions may result in death, serious personal injury, severe product and/or property damage, including voiding of the Lippert limited warranty.

⚠ WARNING

THE "WARNING" SYMBOL ABOVE IS A SIGN THAT A SAFETY RISK IS INVOLVED AND MAY CAUSE DEATH, SERIOUS PERSONAL INJURY AND/OR SEVERE PRODUCT OR PROPERTY DAMAGE IF NOT SAFELY ADHERED TO AND WITHIN THE PARAMETERS SET FORTH IN THIS MANUAL.

⚠ WARNING

FAILURE TO FOLLOW INSTRUCTIONS PROVIDED IN THIS MANUAL MAY RESULT IN DEATH, SERIOUS PERSONAL INJURY AND/OR SEVERE PRODUCT AND PROPERTY DAMAGE, INCLUDING VOIDING OF THE COMPONENT WARRANTY.

⚠ WARNING

THE TRAILER MUST BE SUPPORTED PER MANUFACTURER'S RECOMMENDATIONS BEFORE WORKING UNDERNEATH. FAILURE TO DO SO MAY RESULT IN DEATH OR SERIOUS INJURY.

⚠ CAUTION

THE "CAUTION" SYMBOL ABOVE IS A SIGN THAT A SAFETY RISK IS INVOLVED AND MAY CAUSE PERSONAL INJURY AND/OR PRODUCT OR PROPERTY DAMAGE IF NOT SAFELY ADHERED TO AND WITHIN THE PARAMETERS SET FORTH IN THIS MANUAL

⚠ CAUTION

MOVING PARTS CAN PINCH, CRUSH, OR CUT. KEEP CLEAR AT ALL TIMES.

Parts List

Part numbers are shown for identification purposes only. Not all parts are available for individual sale. All parts with a link to the Lippert Store can be purchased.

Equa-Flex Tandem Axle 4-6K Aftermarket Kit

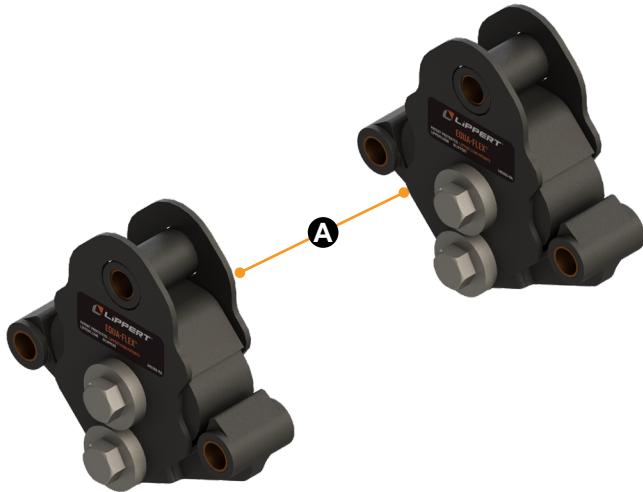

Equa-Flex Tandem Axle 4-6K Aftermarket Kit # 2024114953

Letter	PN	Description	Qty
A	1583774	Equa-Flex; Tandem Axle; 4-6K	2

Equa-Flex Tandem Axle 5-8K Aftermarket Kit

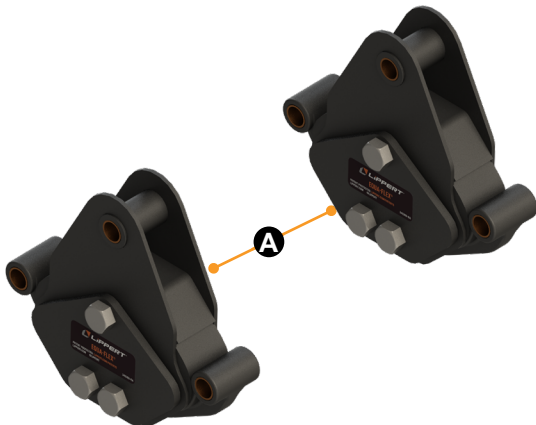

Equa-Flex Tandem Axle 5-8K Aftermarket Kit # 2024115051

Letter	PN	Description	Qty
A	1455253	Equa-Flex; Tandem Axle; 5-8K	2

Equa-Flex® Tandem Axle Installation and Owner's Manual (For Aftermarket Applications)

Parts Available for Purchase

The parts listed are **NOT** part of the Equa-Flex Tandem Axle Kit but can be purchased separately. It is always recommended to inspect and replace any worn or damaged shackles and bolts.

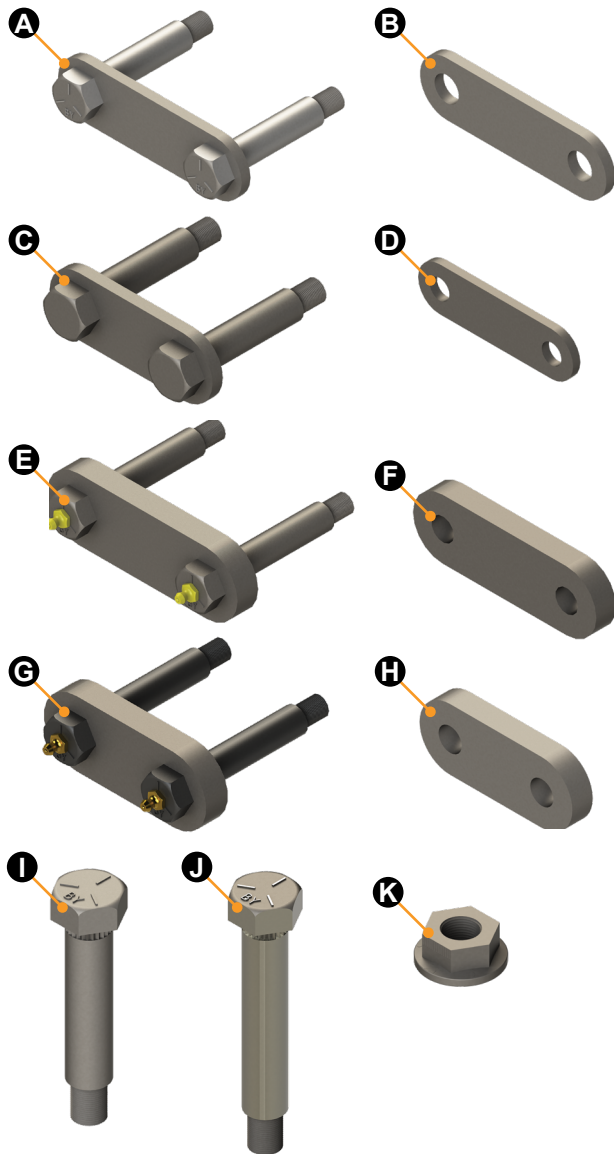

Parts Available for Purchase Shackle Links and Assemblies

Letter	PN	Description	Qty
A	133485	Shackle Assembly, Standard Long, 3.13"	1
B	133207	Shackle Link, Standard Long, 3.13"	1
C	125675	Shackle Assembly, Standard Short, 2.25"	1
D	122487	Shackle Link, Standard Short, 2.25"	1
E	156766	Shackle Assembly, Heavy Duty Long, 3.13"	1
F	1567651	Shackle Link, Heavy Duty Long, 3.13"	1
G	126205	Shackle Assembly, Heavy Duty Short, 2.25"	1
H	126172	Shackle Link, Heavy Duty Short, 2.25"	1
I	122102	Bolt, 9/16" x 2.325" Body with 7/16" - 20 Threaded End	1
J	271254	Bolt, 9/16" x 2.825" Body with 7/16" - 20 Threaded End	1
K	122103	Nut, 7/16" - 20 REVLKN ZN GR2 ST	1

Resources Required

- 1 to 2 People, depending on task
- Pneumatic impact wrench
- Torque wrench (ft-lb)
- Cordless or electric drill or screw gun
- Appropriate drive bits
- 1¹/₁₆" Deep well socket
- 3³/₄" Deep well socket
- 1³/₁₆" Deep well socket
- Appropriately-sized and rated bolts and fasteners
- Floor jacks
- Floor jack stands
- Hammer

Prior to Installation

WARNING

MAKE SURE THAT ANY POINTS OF CONTACT FOR THE JACK STANDS DO NOT RESULT IN DAMAGE TO ANY PANELS OR LINES UNDER THE TRAILER. IMPROPER RAISING OR LOWERING OF THE TRAILER COULD RESULT IN DEATH, SERIOUS INJURY OR SEVERE PRODUCT OR PROPERTY DAMAGE.

1. Using the properly-rated floor jacks, lift the trailer according to the manufacturer's recommendations until the wheels are no longer in contact with the ground (Fig.1).
2. Support framework in accordance with the manufacturer's recommendations.

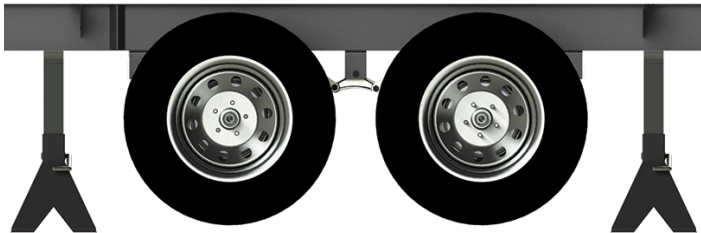

Fig.1

3. Remove the tires and wheels from the trailer. The suspension should be free from any loads, except its own weight at this point.
4. Place another set of jack stands under the axles, close to the U-bolt plates. This will provide support to the axles and ensure that they do not swing down during disassembly of the shackle components.

NOTE: Allowing the axles to drop could result in damage to the wiring for the electric brakes.

5. Remove the two shackle nuts (Fig.2A) on the shackle at the rear of the front spring.

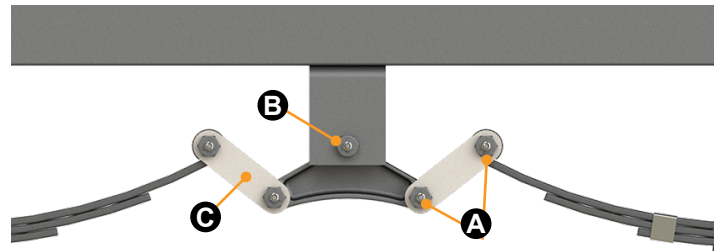

Fig.2

NOTE: The bolts are pressed into the shackle plate and should not turn. However, use a properly-sized box end wrench to make sure the bolts do not turn during the removal of the nuts.

6. After the nuts and the shackle plate are removed, remove the shackle plate with the bolts from the other side.
7. After removing the front spring's shackles at the equalizer, repeat the process for the shackles (Fig.2C) that mate the rear spring to the equalizer.
8. Remove the nut on the cross bolt for the equalizer (Fig.2B). Again, the bolt may be pressed into the frame hanger and should not be allowed to rotate.
9. Remove the old equalizer.

NOTE: Lippert recommends using new shackle links with shackle bolts and nuts for installation of the Equa-Flex. Shackle Link kits not included.

Installation

⚠ WARNING

THE TRAILER MUST BE SUPPORTED PER MANUFACTURER'S RECOMMENDATIONS BEFORE WORKING UNDERNEATH. FAILURE TO DO SO MAY RESULT IN DEATH OR SERIOUS INJURY.

NOTE: Reference figure 3 rear Equa-Flex axle for component clarification during installation.

NOTE: When installing the Equa-Flex Equalizer into the center frame hanger, the Equa-Flex Equalizer label should be facing out.

1. Install the equalizer bolt through the frame hanger outside plate, the top most bronze equalizer bushing, and through the frame hanger inside plate.
2. Use a hammer and drive the bolt into the frame hanger outside plate, until the bolt head is seated against the hanger surface.

3. Both the shackle bolts and equalizer bolt must be installed from the outside-in towards the center of the trailer chassis. This ensures that the bolt threads do not interfere with any other assemblies.
4. Thread a nut onto the exposed equalizer bolt thread until the nut seats against the hanger. Torque the nut until it bottoms out on the bolt shoulder at 30-50 ft-lbs.
5. Place the axles into the normal operating position.
6. Attach the new shackle links with shackle bolts and mounting nuts.
7. Torque the nuts until they bottom out on the bolt shoulder at 30-50 ft-lbs.
8. Repeat steps 1-7 for the opposite side of the trailer.
9. Lower the trailer evenly to the ground. Use care to avoid jarring movement. The trailer **MUST** not be dropped to the ground. Make sure the shackle links are upright and located approximately in the 10 o'clock and 2 o'clock position (Fig.3).

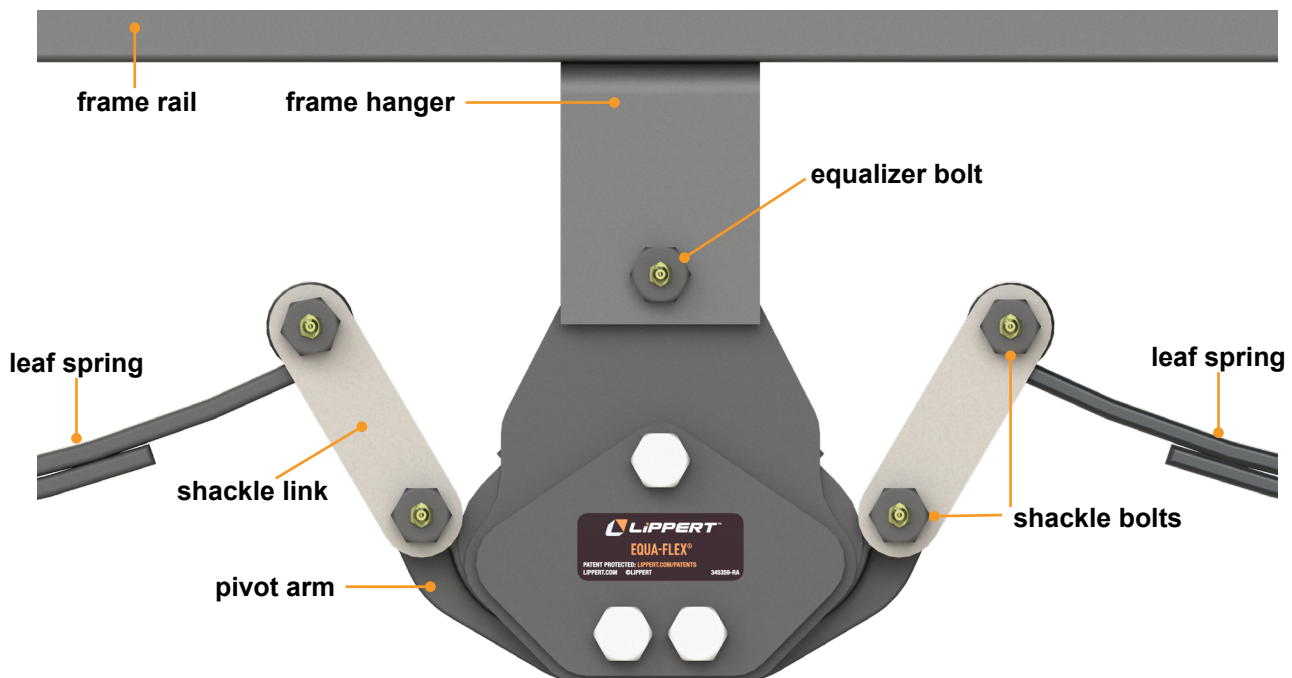

Fig.3



Equa-Flex® Tandem Axle Installation and Owner's Manual (For Aftermarket Applications)



Manual information may be distributed as a complete document only, unless Lippert provides explicit consent to distribute individual parts.

All manual information is subject to change without notice. Revised editions will be available for free download at lippert.com. Manual information is considered factual until made obsolete by a revised version.

Please recycle all obsolete materials and contact Lippert with concerns or questions.