



HIGH PRECISION BATTERY MONITOR

MODEL: FBM08A10C / FBM08A35C

LIPPERT ITEM NO.: 2021124459/ 2021124534

USER MANUAL



* Product picture for reference only

Furrion battery monitor measures voltage, current, and battery capacity in real time. It can help user accurately understand the status of battery pack, and includes a power-down memory function.

This product works with 8V-30V battery pack, such as the most common RV deep cycle; Wet cell, AGM and Lithium batteries.

- Model FBM08A10C should be used for battery current that is less than 100A.
- Model FBM08A35C should be used for battery current that is larger than 100A and less than 350A.

PRODUCT OVERVIEW

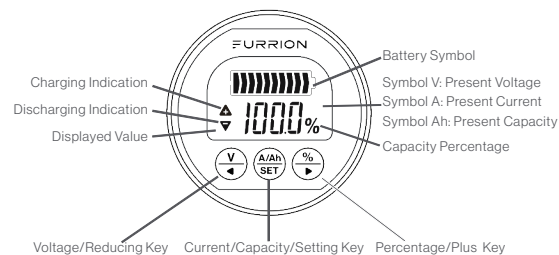

Product Dimension

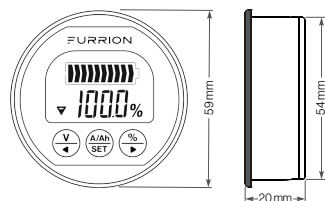

WHAT'S IN THE BOX

- Battery Monitor
- Shunt Resistor
- Shielded Cable Wire
- Mounting Clamp Bracket
- User Manual
- Warranty Manual

INSTALLATION

CAUTION

- Do not put the battery monitor in direct sunlight, or in the environment below 14°F (-10°C) or above 140°F (60°C) for a prolonged period, which will shorten the lifetime of the LCD screen.
- The shunt is recommended to be put as close as possible to the battery, but not be exposed directly to the elements, e.g. rain.
- The shunt must be mechanically secured, as its metal exposed parts are GND and if not secured could cause unwanted shorts, fire, or even an explosion of the battery.
- Ensure wires connected to the battery are properly mounted – nuts must be tightened securely, so that the wires don't move, get loose during vibrations.

Mounting the Shunt

Secure the shunt by using #4 or 3mm screws with pan heads (not included), to prevent accidental contact. There are 3 holes provided for mounting on the shunt as shown.

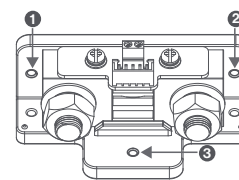

NOTE: Mounting at least 2 holes is recommended. Do not place in or cover with insulating material to allow adequate ventilation for cooling.

Mounting the Power Monitor

Cut a 2 1/8" (54.5mm) round hole on the equipment panel, tighten the installation supporter with butterfly nut to clamp to the panel as shown.

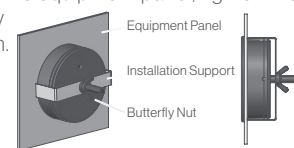

NOTE: The "equipment panel" is not included.

Connection

1. Connect the shunt in series with the negative circuit of the battery pack as illustrated. Ensure the ends of the shunt marked B- and P- are connected correctly as illustrated.
2. Connect a fused (5A max) AWG#18 to AWG#22 wire between the shunt and a 12V+ supply as illustrated. Using a 2-2.5mm slotted screwdriver is recommended to connect the shunt.
3. Connect the provided shielded wire between the shunt and battery monitor as illustrated.
NOTE: The length of the shielded wire is 32.8 feet (10m). Ensure the shunt and monitor are within reach. The shielded wire can not be spliced to add length.

NOTE: Most power consuming equipment utilizes the RV chassis frame as a current return path to the battery. Therefore the battery negative is bonded typically very close in proximity to the chassis. The shunt must be added in-line between the battery and chassis frame for accurate use of the meter. No other power consuming component can be attached to B-, all loads must connect to P-.

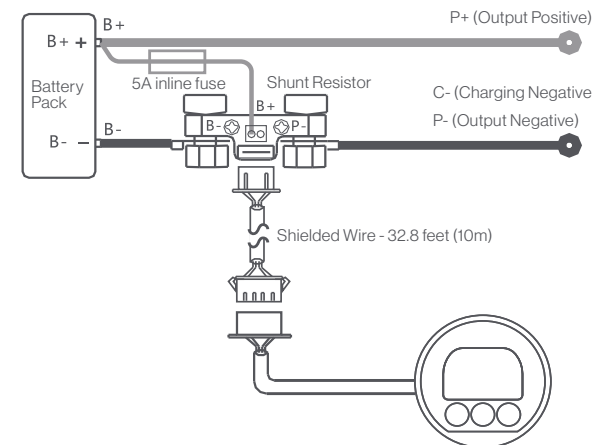

Connection Diagram



The contents of this manual are proprietary and copyright protected by Lippert. Lippert prohibits the copying or dissemination of portions of this manual unless prior written consent for an authorized Lippert representation has been provided. Any unauthorized use shall void any applicable warranty. The information contained in this manual is subject to change without notice and at the sole discretion of Lippert. Revised editions are available for free download from lippert.com.

Please recycle all obsolete materials.

For all concerns or questions, please contact Lippert
Ph: 432-LIPPERT (432-547-7378) | Web: lippert.com | E-mail: customerservice@lci1.com

SET UP AND OPERATION

Battery Capacity Calibration and Setting

Each battery has a capacity rating, typically measured in Amp-hrs (Ah). For accurate use, the meter needs to be calibrated and set for the battery capacity.

NOTE:

- For multiple batteries tied in Parallel, add each battery capacity together.
- For multiple batteries tied in Series, add the voltage together, the capacity remains the same.

Discharge the battery bank by turning loads on in your RV and disconnecting any charging equipment. DO NOT discharge battery below 10.5 volts. Once discharged, begin the following:

- Press to display battery capacity %.
- Press and Hold for 3 seconds, this will calibrate the meter to indicate the battery is at 0% capacity (empty).
- Press to display Ah battery capacity, then press for 3 seconds to enter setting mode.
- Press to increase Ah value to the max or a value reasonably greater than the capacity of the battery bank. Press to set the value.
- Charge the battery bank completely until the Ah or % capacity stops increasing. Charging may take over 24hrs to stabilize.
- Repeat step 3, 4, but instead set capacity to the Ah value indicated by the meter from fully charging the battery bank. (This is the true capacity of the battery bank.)

- Press to display battery capacity %, press for 3 seconds to set the meter to 100%.

The meter is now calibrated and set for the capacity of the battery bank.

NOTE: Battery capacity diminishes with age and charge cycles. The meter does not self calibrate with change in Battery capacity. Therefore, the above steps should be repeated occasionally to keep accurate calibration.

The battery monitor will power on automatically, and for the first time will display an arbitrary setting for battery capacity. After calibration, the meter will always remember these settings until they are manually changed.

Navigating the Meter Display

- Checking Current: Press to display amperage (A) or current. This will show the current flowing in and out of the battery. If the arrow is the current is flowing into the battery and is charging. Likewise, if the arrow is , the current is flowing out of the battery and it is dis-charging.
- Checking Voltage: Press to display the real-time voltage of your battery bank.
- Checking Battery Capacity: It is important to monitor the status of your battery capacity to ensure ample power will be available. The capacity will increase or decrease depending if the battery is charging or discharging. Battery capacity can be displayed in two ways:

- Amp-hr (Ah) Battery Capacity:** Press to display Ah. The number displayed indicates the Amp-hr (Ah) power capacity remaining in the battery bank.
- Battery Capacity "Fuel" Gauge:** Press to display the % "Fuel" remaining in the battery. This is the easiest display to understand how much power remains in the batteries until empty.

Display Function

- The display back-light will be a slow-cyclical pulsing illumination if the battery is charging.
- The display back-light will be a constant illumination if the battery is dis-charging.
- The display back-light will not illuminate if the battery is neither charging or dis-charging.

NOTE:

- The display may flicker on/off when significant motor loads are utilized, this is normal and does not change accuracy of the meter.
- If significant interruptions occur due to nearby electric current fluctuations, it may be necessary to relocate the meter.

Turning Back-light on/off

Press and together for 3 seconds to turn back-light on/off.

SPECIFICATIONS

Working Voltage	8-30V
Working Consumption	10.0-12.0mA
Stand-by Consumption	0.5-0.6mA
Sleep Consumption	50.0-60uA
Accuracy of Voltage Collecting	±1.0%
Accuracy of Current Collecting	±1.0%
Accuracy of Capacity Collecting	±1.0%
Back-light on Current (>50A specification)	100mA
Setting Value of Capacity	0.1-999.0Ah
Temperature Range in Application Environment	-10-60°C (14-140°F)
Weight of 100A Shunt	16.5oz (469g)
Weight of 350A Shunt	21.9oz (620g)
Shield Wire Length of 100A Shunt	32.8 feet (10m)
Shield Wire Length of 350A Shunt	32.8 feet (10m)
Appearance Size	ø2½ x ¾" (ø59 x 20mm)
Hole Size	ø2½" (ø54.5mm)