

F1S17L02A-BL / F1S17L02A-SS / F1S17L03A-BL

17" RV 3-Burner Gas Range



F1S17L02A-BL



F1S17L02A-SS



F1S17L03A-BL



Optional: Drawer Front
CF1SL02ABLA1



Optional: Drawer Front
CF1SL02ASSA1



Optional: Drawer Front
CF1SL03ABLA1



Main Features



CAPACITY



OVEN
POWER



PIEZO
IGNITION



GAS
BURNERS



IMPROVED
HEAT DISTRIBUTION



FLUSH MOUNTED

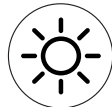

OVEN LIGHT
BULB



GAS AUTO
SAFETY CUT-OFF
(OVEN BURNER)

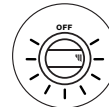

INNOVATIVE
LED INDICATOR

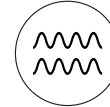

VIBRATIONSMART

FURRIION

Range

Top view without glass cover

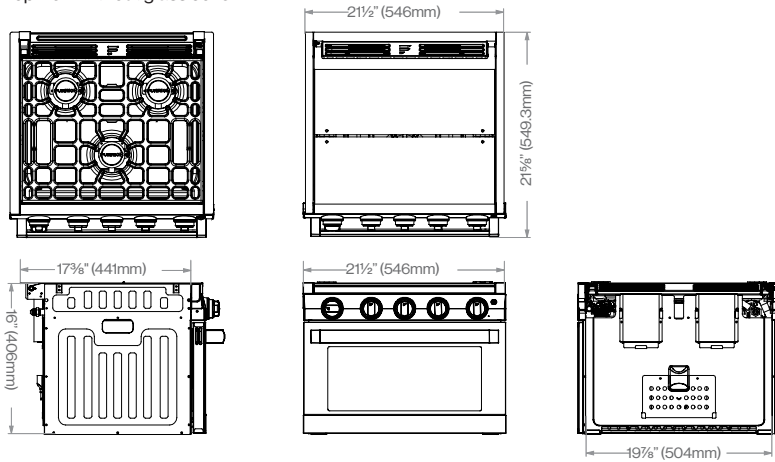

Drawer Front

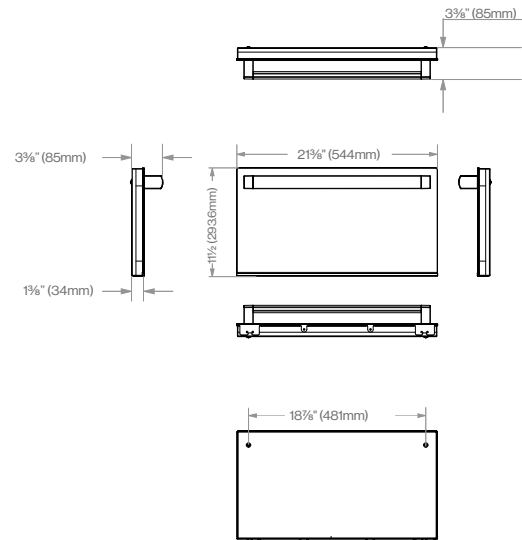

Specifications

Oven

Total Oven Capacity	1.24 cu. ft. (35.24L)
Cavity Dimensions (L x W x H)	17 x 14 1/8 x 8 7/8" (432 x 360 x 227mm)
Oven Cooking Technology	Conventional (bottom-up heat transfer)
Oven Temperature Range	350 to 475°F (146 to 246°C)
Oven Burner Power	7,100 BTU
Gas Safety Cut-off Valve	✓
Triple Layer Glass	✓
Enamel Non -Stick Coating	✓
Cavity Light	1 (10W, Halogen Light)
Number of rack positions	2
Number of racks included	1

Cooktop

Cooktop type and Surface	Gas with Matt Enamel Stamped Grate
No. of Burners	3 Burners
Power & Size	Front: 8,000 BTU (2.4") Rear Right: 6,500 BTU (2.4") Rear Left: 6,500 BTU (2.4")
Glass Cover	2-piece folding cover

Other Specifications

Ignition Type	Piezo Igniter
Fuel Type	Propane
Control Type	2-color LED Knobs: Blue: Decorative Red: For Safety (Burner ON with gas flowing)
Control Location	Front Panel
Storage Drawer	Optional Drawer Front for Drawer
Power Source	12V DC

Applications

Specialty Vehicle	✓
Food Truck	✓

Dimensions, Weight & Container load information

Range

Product Dimensions (L x W x H)	21 1/2 x 21 1/8 x 16" (546 x 549 x 406mm)
Packaging Dimensions (L x W x H)	25 x 24 3/4 x 19 7/8" (635 x 630 x 505mm)
Net Weight (lbs/kg)	F1S17L02A-BL: 53.7/24.4 F1S17L02A-SS: 54.2/24.6 F1S17L03A-BL: 53.7/24.4
Gross Weight (lbs/kg)	F1S17L02A-BL: 59.3/26.9 F1S17L02A-SS: 59.7/27.1 F1S17L03A-BL: 59.3/26.9
40'HQ Container Load (pcs)	286

Drawer Front

Product Dimensions (L x W x H)	21 1/8 x 3 3/8 x 11 1/2" (544 x 85 x 294mm)
Packaging Type	Carton Box
Quantity Per Box (pcs)	2
Packaging Dimensions (L x W x H)	24 3/8 x 8 7/8 x 15" (620 x 220 x 380mm)
Net Weight (lbs/kg)	CF1SL02ABLA1: 19.8/9 CF1SL02ASSA1: 9.9/4.5 CF1SL03ABLA1: 19.8/9
Gross weight (lbs/kg)	CF1SL02ABLA1: 20.5/9.3 CF1SL02ASSA1: 10.5/4.8 CF1SL03ABLA1: 20.5/9.3

F1S17L02A-BL / F1S17L02A-SS / F1S17L03A-BL-V1.11

CCD-005737 | REV DATE: 04.28.23

For all concerns or questions, please contact Lippert | Ph: 432-LIPPERT (432-547-7378) | Web: lippert.com | E-mail: customerservice@lci1.com
Furrion® and the Furrion logo are trademarks licensed for use by Furrion Ltd. and registered in the U.S. and other countries. © 2007-2022 Furrion Ltd.

