

# Furrion eRove™ 50QT Electric Cooler



## Keep it cool no matter where you are.

The Furrion eRove™ has been designed to accompany you on all your outdoor adventures. Using compressor technology and Furrion ePod™ battery, this iceless cooler keeps your food and drinks cold for up to 5 days thanks to its low energy consumption and smart presets.

Equipped with a wheel kit, the sleek and robust design is ideal for cooling on-the-go regardless of weather conditions.

## Key Benefits

**Up to 5-day ice retention without power supply:** With high-performance foam insulation technology, Furrion eRove™ will retain ice for up to 5 days. Thanks to its low energy consumption and its smart mode, the Furrion eRove™ electric cooler gives you the assurance of cold drinks and fresh food even when you are completely off-grid.

**The perfect travel companion:** Harness the power of the sun to keep your cooler running longer. Furrion eRove™ and Furrion ePod™ batteries are compatible with Furrion Solar Panels for a modern and sustainable energy solution. The efficient 12V DC input regulates the current for peak charging, giving you an efficient backup power source whenever you need it.

**Charge on the Go:** The Furrion eRove portable electric cooler features 3 USBs ports and the latest wireless charging technology to keep your favorite devices fully charged when your Furrion eRove™ is plugged into AC or while using the ePod™ while you are on the go.

## Main Features



CAPABLE OF FREEZING TO -8°F



COMPATIBLE WITH FURRIION EPOD™ BATTERY



SOLAR RECHARGEABLE



LCD DIGITAL DISPLAY



WIRELESS CHARGING



SMART MODES



INTERIOR LED LIGHTS



2 USB 2.0  
1 USB 3.0



EASY MOBILITY WITH WHEEL KIT\*

## Functions

- Beverage mode
- Freezer mode
- Eco-mode
- Wireless Charging
- 1x USB 3.0
- 2x USB 2.0

# FURRIION

\*Results may vary according to testing conditions \*Wheel Kit Sold separately

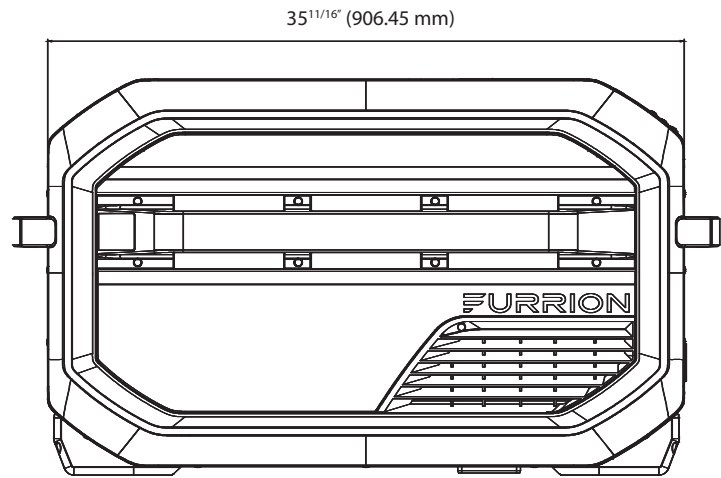
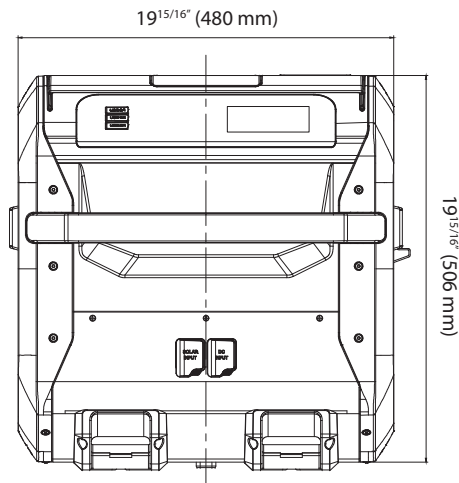

## Specifications

Capacity (quarts/liter)	49 / 46.1
Can Capacity	72
Refrigeration Technology	Compressor
Preset Programs	Freezer, Beverage, ECO, USB
Control Type	Electronic
Handle	Retractable Pull Handle
Wheels	Detachable
Interior LED Lights	Dry storage and cooling compartments
Compatible with	Furrion ePod™ Battery Furrion Solar Panel ≥100w
Accessories (Sold Separately)	Umbrella holder, Dual cup holder, Wheel kit
Voltage	12V DC
Refrigerant	R134a
Temperature setting	-8 °F to +50 °F (-22 °C to +10 °C)
Noise Level	≤ 45dB(A)
Weatherproof	√
Flushback Skin Evaporator	√
AC/DC Adaptor	√
Bottle Opener	√
Quick Drain	√
Serving Tray	√

## Dimensions

Product Size (W x L x H)	20.12 x 19.93 x 35.62"
	512 x 507 x 906 mm
eRove™ Net Weight (lbs/kg)	63.8 / 28.9

FCR45DCAPA-GL-V2.3