



**TRAILER AXLE (2K-7K)**  
**OWNER'S MANUAL**



Scan for product support

# Table of Contents

<b>Introduction</b>	<b>3</b>
<b>Safety Information</b>	<b>3</b>
Break-In Period For Electric Drum Brakes	4
<b>Trailer Axle Brake Inspections</b>	<b>4</b>
Recommended Component Inspection Periods	5
<b>Hubs/Drums/Bearing</b>	<b>5</b>
Brake Hub Removal	5
Clean Brake Drum	6
Brake Drum Inspection	7
Disc Brake Rotor and Pad Inspection	7
Disc Brake Caliper	7
Bearing Inspection - Inner and Outer	7
Bearing Cup Inspection and Removal	8
Brake/Idler Hub Installation	9
Inner Bearing Cone and Grease Seal Installation	9
Bearing Lubrication - Oil	11
Oil Seal	12
Periodic Bearing Inspection	12
Spindle Nut Adjustment	12
<b>Disc Brake Option</b>	<b>12</b>
Disc Brake Pads	12
Disc Brake Caliper	12
<b>Electric Brakes</b>	<b>13</b>
How to Use Lippert Electric Brakes Properly	13
<b>General Maintenance - Electric Brakes</b>	<b>14</b>
Brake Adjustment	14
Lubricate Brakes	14
Clean and Inspect Brakes	14
Magnets	15
Shoes and Linings	15
Hub Replacement	16
<b>Axle and Suspension Installation</b>	<b>16</b>
Suspension Systems	16
Double-Eye Leaf Springs	16
Slipper Leaf Springs - Optional	17
Torsion Suspension System	18
Inspection	18
Equalizer Replacement	19
Suspension Replacement	19
<b>Wheels</b>	<b>19</b>
Wheel Selection	19
Torque Requirements	20
Tires	21
<b>Introduction to Troubleshooting</b>	<b>22</b>
Troubleshooting	22
Troubleshooting Chart	22
Measuring Voltage	22
Measuring Amperage	22
Amperage Chart	23
<b>Maintenance Schedule</b>	<b>26</b>
<b>Wiring Diagram</b>	<b>27</b>
<b>Pigtail and Coupler Wiring Color Codes</b>	<b>28</b>
<b>Storage</b>	<b>29</b>
Storage Preparation	29
Extended Storage Inspection Procedures	29
<b>Trip Preparation Checklist</b>	<b>29</b>
<b>Limited Warranty</b>	<b>30</b>

## Introduction

Combining years of experience in the trailer frame and recreational vehicle industry with the newest and most innovative technology, Lippert introduces the Axle and Running Gear Division.

The following publication is designed to give the customer an easy-to-understand operation and service manual to provide useful and important information. The quality of the Lippert name and the finest materials utilized in the production of the Axles and Running Gear provide you with hubs, brakes, drums and spindles that make trailering and braking the finest in the industry.

Quality comes threefold at Lippert:

1. The finest quality materials.
2. The latest technology and design.
3. The quality standards maintained from materials to final assembly.

For information on the assembly or individual components of this product, please visit:

<https://support.lci1.com/axles-and-suspension>

A QR code on the axle serial number label will also supply access to this online support documentation as well as provide information for OEMs. If using an Android camera phone to scan the label's QR code, it will provide a link to the website in addition to information on serial number, load rating, item number and description, customer and manufacturer purchase information and manufacture date. If using an iPhone, scanning the QR code with its camera will supply only the Lippert website link. A QR code reader app is needed on an iPhone to access the OEM information.



## Safety Information



**The "WARNING" symbol is a sign that precedes a service, maintenance or operational procedure containing a possible personal safety risk that could result in serious injury or death if stated safety precautions and procedural steps are not followed as set forth in this manual.**



**Performing service, repair or routine maintenance work can cause personal injury or death. Use personal protective equipment (PPE) whenever performing service work or routine maintenance. Make sure work space is clean and free of slip or trip hazards.**

Always wear eye protection when performing service or maintenance to the vehicle. Other safety equipment to consider would be hearing protection, gloves and possibly a full face shield, depending on the nature of the service.

This manual provides general service and maintenance procedures. Many variables can change the circumstances of the service procedure, e.g., the degree of difficulty involved in the service operation and the ability level of the individual performing the operation. This manual cannot begin to plot out procedures for every possibility, but will provide the general instructions for effectively servicing the vehicle. In the event the skill level required is too high or the procedure too difficult, a certified technician should be consulted before performing the necessary service. Failure to correctly service the vehicle may result in voiding the warranty, inflicting injury or even death. The owner's manual for your trailer may have more procedures for service and maintenance.

### Break-In Period For Electric Drum Brakes

**NOTE:** Brakes should be manually adjusted after the first 200 miles (322 km) of operation, then periodically every 3,000 miles (4828 km).

The break-in period is a typical phenomenon with drum brakes and especially electric drum brakes. Electric drum brakes will require a break-in period to achieve full performance. This break-in period applies for new axles and any time new brake shoes and/or magnets are installed as part of regular maintenance. Lippert has found through extensive brake testing that the break-in period for our drum brakes can range from 20 to 50 brake applications.

Brakes can be seated in by applying approximately 8-10 volts to the trailer brakes at an initial speed of 40 mph and allowing the truck/trailer combination to slow down to 20 or 25 mph (32 or 40 km/h). For best results do not use truck brakes during this procedure. The trailer brakes will seat in faster by using them to stop both the truck and trailer. The easiest method is to apply the trailer brakes using the manual activation lever located on the in-cab brake controller. Care **MUST** be taken to not overheat the lining material, therefore brake applications conducted at one mile intervals will suffice. The driver should feel a noticeable difference in the brake performance during this period, sometimes in as few as 10 applications. After 50 applications, the brake lining material will be fully cured from the heat and develop close to 100% contact with the brake drum surface.

This break-in period not only seats the shoe lining material but also seats in the brake electromagnets. During the break-in period, the linings will wear at a faster rate than they do after they are seated in.

### **Trailer Axle Brake Inspections**

In general, based on normal activity, trailer brakes should be checked annually or every 36,000 miles (57,936 km), whichever comes first. If above normal trailer activity is experienced, then more frequent brake component inspections are recommended. In the event the braking system encounters symptoms of improper application or failure, immediate inspection and service **MUST** be performed.

## Recommended Component Inspection Periods

- Periodic Bearing Inspection - Should be performed annually or every 36,000 miles (57,936 km), whichever comes first.
- Bearing Lubrication Inspection - Should be performed annually unless periodic brake inspections reveal abnormal braking performance.
- Brake Cleaning and Inspection - Should be performed annually or every 36,000 miles (57,936 km), whichever comes first.

## **Hubs/Drums/Bearing**

**NOTE:** A small amount of residual grease on the outside of a new brake hub is normal. Simply wipe the residual grease off of the brake hub. However, it is not normal for a hub to continue to weep grease after its initial installation. Excess grease can coat brake pads, magnets and braking surfaces inside of the hub, resulting in diminished braking capability. Have the brakes checked by a qualified service provider.

## Brake Hub Removal



**Always lift the trailer by its frame and never by its axle or suspension. Axle and suspension components are not designed, or rated, for the dead weight, point-of-contact loads that the trailer's frame is. Do not go under the trailer unless it is supported by appropriately rated jack stands. Improperly supported trailers can collapse, causing possible serious personal injury or death.**



**Wear appropriate personal protective equipment (PPE) when performing service or maintenance operations. Always wear eye protection when servicing trailer axles, brakes, hubs, springs and wheels. Not using PPE may result in serious personal injury or death.**

Disassemble the brake hub assembly for inspection, maintenance or service as follows:

1. Make sure trailer is on level ground.
2. Chock tires before beginning wheel disassembly.
  - A. Chocked tires will prevent trailer from rolling while brakes are disengaged during disassembly, cleaning, inspection and assembly operations.
3. Loosen wheel lug nuts before raising the trailer to prevent tire from spinning during lug nut removal.
4. After lug nuts have been loosened, raise the trailer until the tire spins freely.
  - A. Continue to lift and support trailer per manufacturer's requirements.
    - I. Use appropriately rated jack stands.
    - II. Place jack stands under the trailer's frame only.
5. Remove all lug nuts from wheel, then remove wheel from brake hub.
  - A. Set wheel and lug nuts aside for later re-assembly.
  - B. Do not lean removed tire against trailer or any jacks. Leaning a heavy tire against a suspended trailer could cause damage to the outside of the trailer or place undue side pressure against a jack, possibly causing the trailer to become unstable.
6. Prior to brake hub disassembly, create a clean area to place removed parts to prevent possible contamination or damage to removed parts.

7. Remove dust cover from hub by prying its edge out of the hub.
  - A. If servicing a brake drum, remove the lubed dust cap with the installed lubed rubber plug.
  - B. If servicing an idler hub, remove the non-lubed dust cap.
  - C. If brake or idler hub assembly is equipped with oil lubrication, place a drip pan underneath the hub.
    - I. Unscrew oil cap using a 2 1/2" socket wrench.
    - II. Let oil drain into drip pan.
8. Pull cotter pin from spindle (castle) nut and discard.
  - A. The cotter pin is a one-time-use item. Do not re-install removed cotter pin.
9. Remove the spindle nut.

**NOTE:** Remaining grease on components can act as a mastic. Inspect removed spindle nut for attached spindle washer.

10. If spindle washer did not come off with the spindle nut, inspect the outer bearing. Grease may have allowed the washer to stick to it.
  - A. Remove spindle washer.
11. Pull brake or idler hub off of spindle as follows:
  - A. Make sure brakes have been disengaged.
  - B. To prevent outer bearing cone falling freely from the assembly, place one hand on the backside outer rim of the hub and the other hand over the outside of the hub bore to cover the bearing cone.
  - C. Slightly turn the hub while pulling to free the hub from the spindle.
    - I. The outer bearing cone will want to drop out of the hub. Secure the bearing and place it in the clean, removed part area.
    - II. The inner bearing cone and cup remains installed within the hub, contained by the grease seal, and will not fall out.
  - D. Remove the grease seal from hub bore as follows:
    - I. Set the brake or idler hub aside on a clean, solid surface with the outer bearing cup side facing down.
    - II. Use a seal puller or equivalent to remove grease seal from hub.
      - a. Do not re-install removed seal.
      - b. Discard removed seal.

## Clean Brake Drum

Older brake linings may contain asbestos dust, which has been linked to serious or fatal illnesses. Certain precautions **MUST** be taken when servicing brakes:



**Potential asbestos dust hazard. Do not use compressed air, a dry brush or dry rag to remove brake dust. Disturbed brake dust can become an airborne irritant that can be inhaled or ingested, causing serious personal illness or death. Wear appropriate personal protective equipment (PPE). Use aerosol brake cleaner to wash brake dust away.**

Prior to brake drum inspection, clean the brake drum to remove any brake dust or lubricant film.

1. Avoid creating or breathing any brake dust.
2. Do not machine, file or grind brake linings.
3. Use an aerosol brake cleaner to wash away brake dust.
4. Place a drip pan underneath the brake drum to catch the brake cleaner for proper disposal.
5. Completely wash the entire brake drum, including the backing plate, magnet arm and brake shoes.
6. Inspect brake drum, braking components and backing plate for any remaining pockets of oil, grease or dust.
7. Repeat brake washing step if necessary.
8. Proceed with brake drum inspection.

## Brake Drum Inspection

The brake shoes contact the drum's inner surface and the brake magnet contacts the armature. These surfaces are subject to wear and should be inspected periodically.



**Resurfacing procedures can produce metal chips and brake dust that can contaminate the wheel bearings and cause component failure. Make sure that the wheel bearing cavities are clean and free of contamination before reinstalling bearings and seals.**

1. The drum's inner surface should be re-machined if wear is more than 0.030" or out of round by more than 0.015".
2. The drum should be replaced if scoring or wear is greater than 0.090".

**NOTE:** If the brake drum must be re-machined, refer to the Brake Drum Specifications chart for the maximum allowable re-bore inner diameter. If the size of the machined bore diameter exceeds the specified dimension, a new brake drum **MUST** be used.

Brake Drum Specifications	
Drum	Maximum Re-bore Diameter
7"	7.09"
10"	10.09"
12"	12.09"

The inner surface of the brake drum that contacts the brake magnet is the armature surface.

1. If the armature surface is scored or worn unevenly, it should not be machined more than 0.030".
  - A. The magnets should be replaced whenever the armature surface is refaced.
  - B. Similarly, whenever the brake magnet is replaced, the armature surface should be refaced.

## Disc Brake Rotor and Pad Inspection

Disc brake pads are a consumable item. Visually inspect disc brake pads every 36,000 miles (57,936 km) or 12 months, whichever comes first. Disc brake rotor and brake pad surfaces should be visually checked at the same time. If there are deep grooves on one or both rotor surfaces this is an indication of caliper piston, slider bolt or residual pressure problems. Disc brake rotors should be turned when disc brake pads are replaced. Disc brake pads are available through auto parts stores.

## Disc Brake Caliper

If the disc brake caliper mounting bolts are removed to service the brake system, do as follows:

1. Lubricate the inside of the rubber slider bolt caliper bushings.
  - A. The rubber bushings are not compatible with petroleum-based grease.
  - B. Use silicone-based grease only.
2. Apply blue thread locking compound to the threaded area of the caliper mounting bolts.
3. Install caliper mounting bolts. Torque caliper mounting bolts to 40-50 ft-lbs (54-58 Nm).

## Bearing Inspection - Inner and Outer

An inspection of the bearing condition can detect early bearing issues. Upon inspection, bearings should look brand new and can be reassembled and used if in this condition.

**NOTE:** Bearing cones and cups are not interchangeable after installation. Each bearing **MUST** always be matched with its mating cup. Bearing cones and cups are replaced in matching sets of one cone and one cup.



**Wear personal protective equipment (PPE) when using caustic materials. Aerosol, liquid and oil-based paste materials can present splash hazards and skin contact environments that can result in serious adverse eye and skin irritations. Follow all recommended safety precautions when using such materials.**

1. Wash all grease and oil from the bearing cones using a suitable solvent.
2. Dry bearing cones with a clean, lint-free cloth.
3. Inspect bearing cone cages and rollers for any pitting, spalling, corrosion, flat spots, abnormal condition or discoloration.
  - A. If any of these imperfections are present, then the bearing cone and cup (race) **MUST** be replaced at the same time.
  - B. Bearings are available at auto part stores.
    - I. See Components pages for part numbers.
4. To remove a bearing cup (race) for replacement from the brake hub, go to [Bearing Cup Inspection and Removal](#) procedure.

### Bearing Cup Inspection and Removal



**Wear appropriate personal protective equipment (PPE) when performing service or maintenance operations. Always wear eye protection when servicing trailer axles, brakes, hubs, springs and wheels. Not using PPE may result in serious personal injury or death.**

Clean brake or idler hub in accordance with [Clean Brake Drum](#) procedure and as follows:

1. Wipe all grease and oil from the hub, using care not to scratch or otherwise mar the bearing race.
2. Apply brake cleaner to hub.
3. Use lint-free cloths to dry the hub and bearing cups.
4. Inspect bearing cups (raceways) for pitting, spalling, corrosion, flat spots, abnormal condition or discoloration.
  - A. If the bearing cup (race) is in good condition, and its mating bearing cone is in reusable condition, the cup can remain installed in the hub for reuse.
  - B. If the bearing cup (race) is in good condition, but the bearing cone is not, the cup **MUST** be replaced.
  - C. If the bearing cup (race) is damaged, the cup **MUST** be replaced.

Replace damaged bearing cups (race) as follows:

1. For either inner or outer bearing cup, use a brass drift punch and hammer to lightly tap around the cup's exposed bearing race edge to push it out.
  - A. Move the drift punch evenly around the bearing cup edge to make sure the cup is pushed out evenly to prevent binding or damage to the bearing cup or hub bore.
2. Set the removed bearing cup aside and place it with its mating bearing cone.

**NOTE:** Removed bearing cones and cups are not interchangeable.

**NOTE:** Used bearing cone and cup sets must remain matched and re-installed as a matched set until the set is replaced with a new matching set.

3. After removal of the bearing cups from the hub, re-apply brake cleaner to the hub and the hub bearing cup bores to make sure all surfaces are properly prepared for component reassembly.
  - A. Make sure a drip pan is placed underneath the hub to capture and dispose of the cleaner.

## Brake/Idler Hub Installation

Install the brake or idler hub onto the brake drum or spindle as follows:

1. Obtain appropriate hub for installation.
2. Inspect hub for cleanliness.
3. If both bearing cups are installed in the hub bearing bores, go to the Inner Bearing Cone and Grease Seal Installation procedure.
4. If either one of the bearing cups is not installed in the hub, do as follows:
  - A. Place hub on a solid, flat surface with installed bearing cup side of the hub facing down.
  - B. Obtain the appropriate bearing cup for installation. Refer to the Components pages for part numbers.



**Bearing cup replacement is a precise procedure. When installed, the bearing cup MUST be fully seated against the retaining shoulder of the hub. If the cup is not seated correctly, damage to the completed hub assembly may occur, voiding warranty.**

- C. Bearing cup replacement is a precise procedure. Consult Lippert prior to replacing a bearing cup. The trailer should be taken to a certified service center for this work to be done.
- D. Gently place new bearing cup into hub bearing bore.
- E. Using a brass drift punch, lightly tap around the outer edge of the cup to drive it into the hub bearing bore.
  - I. Continue tapping the drift punch around the circumference of the cup's edge until the cup is fully seated against the hub's bearing bore retaining shoulder.
- F. Wipe the inside of the bearing cup (race) with a clean, lint-free cloth.
  - I. Inspect the bearing cup race to make sure no damage occurred during installation.
5. If no bearing cups are installed in the hub, do as follows:
  - A. Perform step 4 of this procedure.
  - B. Flip hub, exposing the other, open hub bearing bore.
  - C. Perform step 4 of this procedure.
  - D. Make sure both bearing cup races are clean and ready for bearing cone and grease seal installation.
6. After both bearing cups have been installed in the brake or idler hub, go to Inner Bearing Cone and Grease Seal Installation procedure.

## Inner Bearing Cone and Grease Seal Installation

Bearing grease should be replaced every 36,000 miles (57,936 km) or 12 months, whichever comes first.

1. Make sure all old grease has been removed from wheel hub, bearings and axle spindle.
2. Make sure all mating surfaces for new bearing cone and grease seal are clean.
3. Bearings should be packed by machine, if possible, however packing by hand is a viable alternative.

**⚠ WARNING**

**Do not mix lithium, calcium, sodium or barium complex greases. Mixing of these incompatible compounds can create a corrosive and/or toxic chemical with fumes that can result in a serious health risk if exposed to skin or lungs. When converting from one grease to another, make sure all old grease is removed completely prior to applying new grease.**

Hand-pack inner bearing cone as follows:

1. If previously removed inner bearing cone is in reusable condition, place a generous amount of grease into the palm of your hand (Fig. 1).

**NOTE:** Select an appropriate grease that is temperature-rated for the wheel's application. Reference Recommended Wheel Bearing Grease Specifications and Approved Sources - Bearing Grease charts.

**NOTE:**

- A. If previously removed inner bearing cone cannot be reused, obtain a new inner bearing cone. Refer to the Components pages for part numbers.
- B. Place a generous amount of grease into the palm of your hand (Fig. 1).

**Fig. 1**



Approved Sources - Bearing Grease	
Mobil Oil	Mobilgrease HP
Exxon/Standard	Ronex MP
Kendall Refining Co.	Kendall L-427
Ashland Oil Co.	Valvoline Val-plex EP Grease
Pennzoil Prod. Co.	Premium Wheel Bearing Grease 707L

**NOTE:** Select appropriate grease that is temperature-rated for the wheel's application.

2. Press widest end of bearing into the outer edge of the grease pile, forcing grease into the inner area of the bearing between two adjacent rollers (Fig. 1).
3. Repeat this process while turning bearing from roller to roller until all rollers are coated.
4. Apply a light coat of grease into the bearing cup surface (race).
5. Install new grease-packed bearing cone into the cup.

Recommended Wheel Bearing Grease Specifications	
Thickener Type	Lithium Complex
Dropping Point	230°C (446°F) Minimum
Consistency	NLGI No. 2
Additives	EP, Corrosion and Oxidation Inhibitors
Base Oil	Solvent Refined Petroleum Oil
Base Oil Viscosity	@40°C (104°F) 150cSt (695 SUS) Minimum
Viscosity Index	80 Minimum
Pour Point	-10°C (14°F) Minimum

Lippert recommends replacing the grease seal whenever bearing packing is required. Install a new grease seal into the hub seal bore, to capture the inner bearing cone, as follows:

1. Place the new grease seal into the seal bore.
  - A. Apply a light film of sealant onto the outer rim of the seal.
  - B. Make sure seal is set square to the hub seal bore before pressing the seal all the way in or the seal may become damaged.
2. Use a clean, hardwood block of wood and hammer to drive the seal into the seal bore (Fig. 2).
  - A. Place the wood block evenly across the seal.
  - B. Hold the wood block firmly in place as you begin to tap the seal squarely into the seal bore with the hammer.
  - C. Continue to tap the seal inward until the seal's outer face is flush to the hub's seal bore face.

**Fig. 2**



### Bearing Lubrication - Oil

#### **Recommended Oil Lube for Axle Bearings:**

Oil designation : SAE 90, SAE 80W-90, SAE 75W-90

Approved Sources - Bearing Lubrication Oil	
Union Oil Co.	Unocal MP Gear Lube
Exxon Co.	Gear Oil GX 80W-90
Mobil Co.	Mobilube SHC 75W-90
Pennzoil Co.	Gear Plus 80W-90 GL-5
	Gear Plus Super 75W-90

The axle bearings are lubricated with a SAE 80-90W hypoid gear oil. Periodically check oil levels as follows:

1. Make sure trailer has been parked for a few minutes to allow oil to cool.
2. Check and refill brake hub oil to the level indicated on the plastic oil cap.
3. To fill brake hub with oil, remove rubber plug or cap plug from the hub's oil cap.
4. Fill oil through the plastic cap until oil level is complete.
5. Insert rubber plug or cap plug into plastic oil cap.

### **⚠ CAUTION**

**Do not over-tighten plastic oil cap. Over-tightening can damage O-ring, resulting in an oil leak.**

**A.** Tighten oil cap to 25 ft-lbs (34 Nm). Do not over-tighten oil cap or an oil leak may occur. Refer to the Components pages for part numbers. Refer to Approved Sources - Bearing Lubrication Oil chart for recommended axle bearing lubricants.

## Oil Seal

A new two-part oil seal must be installed whenever the brake hub is removed for maintenance. The inside diameter of the two-part seal presses onto the spindle journal, the outside diameter of the seal presses into the brake hub bore.



**Never install a removed oil seal. Installing a removed oil seal may damage the seal, resulting in an oil leak during normal component operation.**



**Make sure the oil seal is properly oriented during part installation. Most oil seals have one side marked "AIR SIDE." This side MUST face outwards and not towards the bearing or component failure will occur.**

Make sure when installing a new oil seal the side marked "AIR SIDE" is facing outward, away from the bearing cone.

## Periodic Bearing Inspection

A physical bearing inspection should be conducted every 36,000 miles (57,936 km) or 12 months, whichever comes first. An inspection of the bearing condition can detect early bearing issues. Upon inspection, bearings should look brand new and can be reassembled and used if in this condition. If discoloration, pitting, corrosion, flat spots or some abnormal condition is observed, the bearing and race should be replaced at the same time. Bearings are available at auto part stores. See Components pages for part numbers.

## Spindle Nut Adjustment

The proper method to assemble the spindle nut is as follows:

1. After hub installation onto spindle, install outer bearing.
2. Install spindle washer, if equipped, and thread on spindle nut with slots facing outward.
3. Torque spindle nut to 50 ft-lbs (68 Nm).
4. Back off torque usually 1/4 turn so that you can finger tighten the spindle nut.
5. Finger tighten, drop cotter pin through slot and hole in spindle. If slot in nut does not align with either hole in spindle, back nut off until it does. Never tighten past finger tight. Use cotter pin hole that provides the least amount of end play clearance.
6. Bend legs over end of spindle and be sure legs do not interfere with oil cap upon reassembly.

## Disc Brake Option

### Disc Brake Pads

Disc brake pads are available through auto part stores. Brake pads are a consumable item so be sure to visually check pads every 36,000 miles (57,936 km) or 12 months, whichever comes first. Be sure to also check rotor surfaces visually when you are checking the brake pads. Deep grooves developing on one or both rotor surfaces can indicate a caliper piston, slider bolt or residual pressure problem if this ever occurs. Brake rotors should be turned when disc brake pads are replaced.

### Disc Brake Caliper

The proper mounting torque for the disc brake caliper mounting bolts is 40-50 ft-lbs (54-68 Nm). If these are removed for servicing the brake system, add blue thread locking compound to the threaded area of the bolt at time of reassembly. Also lubricate the inside of caliper bushings that the slider bolts go through. Be sure to only use silicone-based grease. The rubber bushings are not compatible with petroleum-based greases.

## Electric Brakes

The basic structure of the Electric Brakes on your trailer will resemble the brakes on your car or tow vehicle, with one major difference; your trailer implements an Electric Actuation system and your tow vehicle utilizes a hydraulic system. Refer to the brake components diagram (Fig. 3), the Wiring Diagram (Fig. 13) and Pigtail and Coupler Wiring Color Codes (Fig. 14). The Electric Braking System operates in the following order of steps:

1. Electric current is supplied to the trailer's braking system when the tow vehicle's brakes are applied.
2. From the tow vehicle's battery, the electricity flows to the brake's electromagnet.
3. When energized, the magnets are attracted to the rotating surface of the drums.
4. This moves the actuating levers in the direction the drums are turning.
5. The actuating cam at the end of the shoe forces the primary shoe out to the drum surface.
6. The force of the primary shoe actuates the secondary shoe to contact the drum.
7. The force applied to the brake drum can be increased by elevating the current flow to the magnet.

### How to Use Lippert Electric Brakes Properly

The Lippert Electric Braking System is synchronized with the tow vehicle's brakes. Never attempt to stop the combined load of the tow vehicle and the trailer by using either the tow vehicle brakes or the trailer brakes only. They are designed to work together.

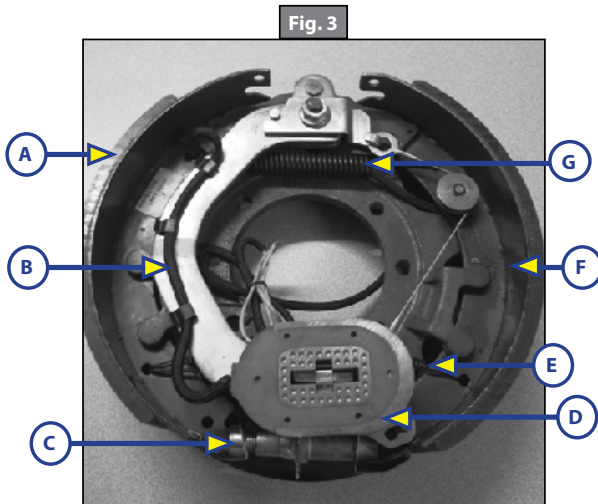

Brake Components	
Callout	Description
A	Primary Shoe
B	Actuating Lever
C	Adjuster
D	Magnet
E	Adjusting Spring
F	Secondary Shoe
G	Retracting Spring

Small manual adjustments may occasionally be necessary to accommodate changing loads and driving conditions. Synchronization of the tow vehicle-to-trailer braking can only be accomplished by road testing. Locking up, excessive grab, or delayed application is quite often due to the lack of synchronization between the tow vehicle and the trailer being towed. High voltage (2V+), Low voltage (2V-) or improperly adjusted brakes are the most common causes of these problems and can easily be corrected.

Prior to any adjustments, your trailer brakes should be burnished-in by applying the brakes 20-30 times with a 20 mph (32 km/h). decrease in speed, e.g. 40 mph. to 20 mph (64 km/h to 32 km/h). Allow ample time for brakes to cool between application. This allows the brake shoes and magnets to begin seating to the brake drum.

## General Maintenance - Electric Brakes

### Brake Adjustment



**Prior to testing or adjusting brakes, be sure area is clear of any persons and vehicles. Failure to perform test in a clear area may result in serious injury or death.**



**Lift the trailer by its frame and never the axle or suspension. Do not go under the trailer unless it is properly supported by jack stands. Unsupported trailers can fall causing serious injury or death.**

The Lippert Electric Brakes are offered in a manual and automatic adjusting form. If manual brake adjusting is required, do as follows:

1. Jack up trailer and secure on adequate capacity jack stands.
  - A. Follow trailer manufacturer's recommendations for lifting and supporting the trailer.
  - B. Make sure the wheel and drum rotate freely.
2. Remove the adjusting hole cover from the adjusting slot on the bottom of the brake backing plate.
3. With a screwdriver or standard adjusting tool, rotate the starwheel of the adjuster assembly to expand the brake shoes.
  - A. Adjust the brake shoes out until the pressure of the linings against the drum makes the wheel very difficult to turn.
4. Rotate the starwheel in the opposite direction until the wheel turns freely with a slight lining drag, or approximately 10 click adjustments.

**NOTE:** A second screwdriver will be needed to push the auto adjusting lever away from the adjuster starwheel so that the starwheel can be rotated backward in the case of a self-adjusting brake.

5. Replace the adjusting hole cover and lower the wheel to the ground.
6. Repeat the above procedure on all brakes.

**NOTE:** For best results, the brakes should all be set at the same clearance. If the first brake's clearance was adjusted to 10 clicks, then adjust the remaining brake clearances to the same amount.

### Lubricate Brakes

Prior to reassembling the brake drum assembly, do as follows:

1. Apply a light film of white grease or an anti-seize compound to:
  - A. The brake anchor pin,
  - B. The actuating arm bushing and pin,
  - C. The areas of the backing plate that are in contact with the brake shoes and magnet lever arm,
  - D. And on the actuating block mounted to the actuating arm.

### Clean and Inspect Brakes

In the event the braking system encounters symptoms of improper application or failure, immediate inspection and service **MUST** be implemented. During normal use, servicing the braking system once a year is considered normal. Above normal use will require servicing based on a 3,000-6,000 mile (4828-9656 km) increment schedule. Change worn magnets and shoes as needed to maintain maximum braking capability.

When disassembling the brakes for cleaning, make sure to:

1. Clean the backing plate, magnet arm, magnet and shoes.
2. Make sure all parts removed for cleaning are placed back into the same brake drum assembly.
3. Check for parts that have become loose or worn.
  - A. Service or replace loose or worn parts.

## Magnets

The Lippert Electric Braking System uses high-quality electromagnets to actuate the brake shoes. These electromagnets provide superior force and friction to safely, and effectively, stop the trailer. Inspect and service the electromagnets annually if the trailer has seen normal use, more often if the trailer is used extensively. Inspect the electromagnets and do as follows:

1. Use a straight edge to check the electromagnet surface for uneven wear (Fig. 4).

**NOTE:** Figure 4 shows an electromagnet with little or no wear.

- A. Surface of electromagnet should be completely flat.
  - B. If abnormal or uneven wear is indicated by pronounced gaps, replace the electromagnet.
2. If the magnet's coil is exposed in any way, even if normal wear is evident, the magnets should be replaced immediately.
    - A. If the electromagnets are replaced, the drum armature surface should be refaced.
  3. If an electromagnet is replaced on one side of an axle, Lippert recommends replacing the electromagnet on the opposite brake assembly. This will ensure an even braking capacity.

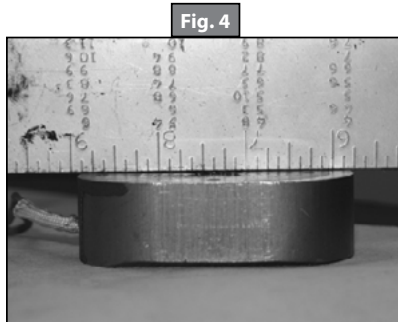

## Shoes and Linings

Inspect brake shoes and linings for:

1. Grease or oil.
2. Surface scoring, pitting or gouges.
3. Replace both shoes if lubricant contamination or physical damage is present, even if found on only one shoe.
  - A. Replace both shoes (two) on the brake and on both brakes (four) installed on the same axle. Replace brake parts at the same time. This will ensure an even braking capacity.
4. Measure lining thickness.
  - A. Lining thickness shall not be less than 1/16".
    - I. If lining measures less than 1/16", replace the shoe.
    - II. Repeat step 3.A.
5. Heat cracks are normal and rarely require attention.

After replacing the brake shoes and linings, burnish-in trailer brakes as follows:

1. Apply the brakes 20-30 times over a 20 mph (32 km/h) decreasing speed range.
  - A. For example, brake 20-30 times while decreasing in speed from 40 mph. to 20 mph (64 km/h to 32 km/h).
  - B. Make sure ample time is allowed for brakes to cool between application.
    - I. The cooling period allows the brake shoes and magnets to begin seating to the brake drum.

## Hub Replacement

To adjust bearings or replace removed hub, follow procedures below:

1. Place hub, bearing, washers and castle nut back on axle spindle in the reverse order from which they were removed. Castle nut should be torqued to 50 ft.-lbs (68 Nm). Hub will rotate during this process.
2. Loosen castle nut to back off the torque.
3. Tighten castle nut finger tight until snug.
4. Insert cotter pin. If cotter pin does not line up with hole, back castle nut up slightly until pin can be inserted (Fig. 5).
5. Bend cotter pin over to lock nut in place. Nut should be free to move with only the cotter pin keeping it in place.

Fig. 5



## Axle and Suspension Installation

### ⚠ CAUTION

**Always wear eye protection when servicing the axle, brakes, hubs, springs and wheels. Failure to wear eye protection may result in serious injury.**

The single most important portion of axle installation is setting the axle(s) square to the center line of the trailer. Axles mounted out of square will cause the trailer to dog track. Dog-tracking is when the axle is not square to the direction of travel. A skewed axle will cause the trailer to swing out to the left or right until the axle becomes square with the direction of travel. When mounting multiple axles to a trailer, take extra care to get the first axle square to the trailer frame. Proper alignment is most readily achieved by measuring from the center of the trailer hitch to the center of each axle spindle. Once the first axle alignment is established, set the remaining axles parallel with the first. Proper installation allows for correct and safe control, prolonged tread life and will all but eliminate dog-tracking.

Lippert tubular axles are made of high strength steel to prevent metal fatigue and provide the best possible welding conditions. The round tubular axles allow for even and uniform structure.

## Suspension Systems

The suspension systems incorporated into Lippert axles are designed to provide the following benefits:

- Attach the axle to the trailer.
- Dampen the effects of road shock.
- Provide stability to the trailer.

All Lippert suspension systems are available in single, tandem and triple axle configurations. For specific or custom applications, please contact the Lippert customer service team.

## Double-Eye Leaf Springs

Double-eye leaf springs have eyes at either end of the spring assembly with nylon bushings to assist in preventing wear. U-bolts hold the springs to the axle with a plate (Fig. 6). Refer to Spring Axle Torque Specifications chart for bolt torque requirements.

**Fig. 6 - Double-Eye Leaf Springs**

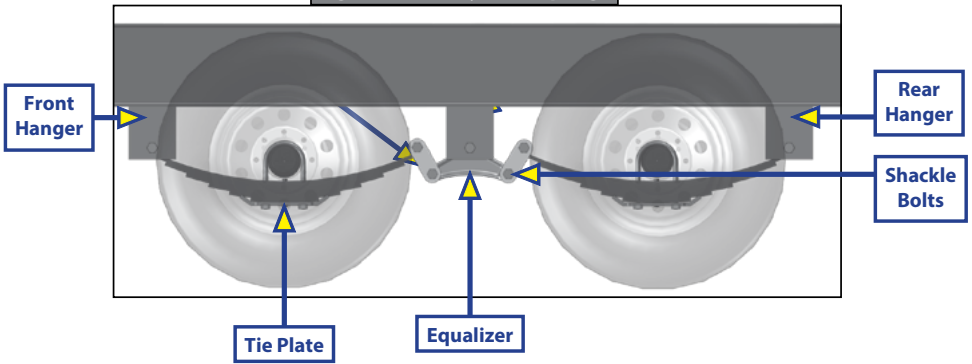

Spring Axle Torque Specifications		
Bolt Type	Axle Capacity	Torque
3/8" U-Bolt Nuts	2K	35 ft-lbs (47 Nm)
1/2" U-Bolt Nuts	3.5K	50 ft-lbs (68 Nm)
9/16" U-Bolt Nuts	5.2K	65 ft-lbs (88 Nm)
9/16" U-Bolt Nuts	6-8K	90 ft-lbs (122 Nm)
Overslung Spring Orientation Silver U-Bolts	7-8K	145 ft-lbs (197 Nm)
Spring Eye, Equalizer and Shackle Nuts	All Double Eye	30-50 ft-lbs (40-68 Nm)
Spring Eye, Equalizer and Shackle Nuts	All Slipper	Snug nut only

The articulation of this suspension occurs when the eyes rotate on the wear surfaces provided in eyes of the springs and on the equalizers. This suspension is also available in single and multiple axle configurations. In trailers with two or more axles, the additional movement is maintained by an equalizer. This feature allows for even load handling from axle to axle.

Double-eye suspension systems are available only on 8,000 lb. axles. Tandem and triple axle mounting kits are available for both 33" and 35" axle spacing.

**Slipper Leaf Springs—Optional**

Slipper springs have a loop eye formed on one end and a reverse radius on the other (Fig. 7). The front eye is secured to either the front hanger or rear of the equalizer with a bolt and nut. The slipper end rides against a wear-block located in either the front of the equalizer or the rear hanger. Refer to Spring Axle Torque Specifications chart for bolt torque requirements.

A keeper bolt or strap is placed under the slipper end to contain the spring when the trailer is lifted off the ground. The 3.5-8K tandem and triple axle attaching kits are available for both 33.5" and 36" axle spacing.

**Fig. 7 - Optional Slipper Leaf Springs**

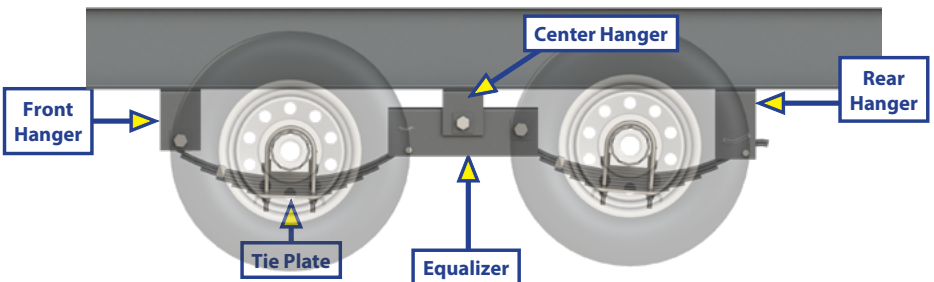

## Torsion Suspension System

The Lippert Torsion Suspension system is designed to offer superior qualities over leaf spring technology. Bracketed to the trailer's frame, and housed inside the trailer axle's tube, the spindle is connected to a swing arm, which is connected to a square inner bar surrounded by four rubber cords inside the axle tube. As the swing arm rotates, the rubber absorbs and distributes torque and resistance loads generated by driving conditions. These characteristics provide a measurable benefit over leaf spring suspensions. Torsion axles provide independent wheel end suspension, quieter ride and more vertical wheel travel for a softer ride compared to leaf spring axles.

The Lippert Torsion Suspension system requires very little maintenance. Normal inspection of the entire Lippert Trailer Axle system can be applied to the Torsion Suspension system. See inspection procedures for system components in this manual.

**NOTE:** For Torsion Suspension System installation, mount axle bracket to frame bracket (Fig. 8) and torque fasteners as specified in the Torsion Axle Torque Specifications chart. Washers **MUST** be placed on both sides of the bracket, including under the nut and under the bolt head (Fig. 8A).

Torsion Axle Torque Specifications		
Axle Size	Bolt Size	Torque Range
2K Axle Capacities	1/2"	70-90 ft-lbs (95-122 Nm)
3.5K-10K Axle Capacities	5/8"	120-150 ft-lbs (163-203 Nm)

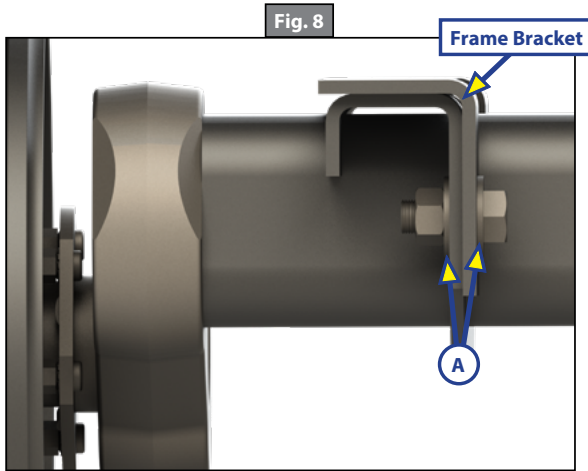

## Inspection

Inspect all components of the suspension system annually or every 36,000 miles (57,936 km), whichever comes first. Visually inspect the system for signs of wear, damage or loose fasteners. Replace or tighten loose fasteners, as necessary. Torque fasteners in accordance with specifications in tables Spring Axle Torque Specifications and Torsion Axle Torque Specifications.

### **⚠ WARNING**

**Lift the trailer by its frame and never the axle or suspension. Do not go under the trailer unless it is properly supported by jack stands. Unsupported trailers can fall causing serious personal injury or death.**

### **⚠ WARNING**

**Lift the trailer by its frame and never the axle or suspension. Unsupported trailers can fall causing damage to the frame, axles, suspension system and the trailer. Improper trailer support will void warranty coverage for incurred damages.**



**Wear eye protection when servicing axles, brakes, hubs, springs and wheels. Failure to wear eye protection may result in serious personal injury.**

Refer to the Components pages and the appropriate Service Kit Part # (illustrated parts list) for part descriptions and numbers of replacement components. Replace worn spring eye bushings and sagging or broken springs as follows:

1. Support the trailer with the wheels just off the ground. Follow the trailer manufacturer's recommendations for lifting and supporting the trailer.
2. After the trailer is properly supported, place a suitable block under the axle tube near the area to be repaired.

**NOTE:** The block acts as a support for the weight of the axle only, allowing suspended system components to be serviced or replaced freely. Multiple axle trailers **MUST** have the weight of each axle properly supported before disassembly of any suspension system component.

3. Disassemble the U-bolts, nuts and tie plates.
4. Remove the spring eye bolts and the spring.
5. If the spring eye bushings are to be replaced, press out the old bushing by hand or use a punch to tap it out.
6. Obtain a new free-floating nylon bushing.

**NOTE:** Free-floating nylon bushings do not require lubrication.

7. Press the new bushing into the spring eye by hand or gently tap it into place with a bounceless rubber or plastic mallet.
8. Install remaining repaired or new suspension system components in reverse order of their original disassembly sequence.

### Equalizer Replacement

Refer to the Components pages and the appropriate Service Kit Part # (illustrated parts list) for part descriptions and numbers of replacement components. Replace equalizer or equalizer bushings as follows:

1. Support the trailer with the wheels just off the ground. Follow the trailer manufacturer's recommendations for lifting and supporting the trailer.
2. After the trailer is properly supported, place a suitable block under both axle tubes.
3. Remove the spring eyebolt, keeper bolt, and equalizer bolt from the equalizer.
4. Press the old nylon bushing out of the equalizer.
5. Install removed equalizer parts in reverse order of their original disassembly sequence.

### Suspension Replacement

Install replacement springs and equalizers as follows:

1. Make sure springs are on straight.
  - A. Align spring eyes to front hanger.
  - B. Insert spring eye bolts and nuts, but do not torque fasteners at this point.
2. Assemble springs to equalizer.
3. Level the equalizer to the frame.
  - A. Torque equalizer nuts and spring eye nuts to 30-50 ft.-lbs (41-68 Nm).

## **Wheels**

### Wheel Selection



**Air pressure on a weakened or cracked rim can create an unsafe, explosive condition resulting in serious personal injury or death. Do not attempt to modify or repair a wheel. Replace damaged or weakened wheel and rim with new.**



**Use manufacturer's suggested rim contours only. Failure to use recommended rim contours may result in dramatic separation between tire and wheel, resulting in possible serious personal injury or death.**

Trailer wheels, tires and axles **MUST** be properly matched when specifying or replacing trailer wheels. Make sure the following critical wheel replacement characteristics are observed:

1. Bolt Circle.
  - A. Wheels have varying bolt circle patterns, some close enough to allow installation of mismatched wheel bolt patterns to axle hub bolt patterns.
2. Capacity.
  - A. Wheel load capacity **MUST** match tire and trailer maximum load ratings.
3. Offset.
  - A. The relationship of the tire's centerline to the axle's hub face **MUST** match across replacement parts.
  - B. Failure to match offset reduces axle carrying capacity.
4. Rim Contour.
  - A. Replacement wheels **MUST** directly match the mating rim contour.

### Torque Requirements

It is extremely important to maintain proper wheel mounting torque limits on your trailer axle. Use of torque wrenches will ensure proper torque limits are applied to wheel mounting lug nuts. Use no other method to torque wheel lug nuts.

Make sure wheel fasteners match the cone angle of the wheel (usually 60° or 90°) being serviced. Attach new wheel to the axle hub as follows:

1. Start all bolts or nuts by hand to prevent cross-threading.
2. Continue to hand-tighten wheel lug nuts in the sequential pattern shown in Figure 9.
3. After wheel lug nuts are fully hand-tightened, torque nuts in stages in the sequential pattern shown in Figure 9.
  - A. Torque wheel lug nuts to the torque values listed in the Wheel Torque Requirement Chart.

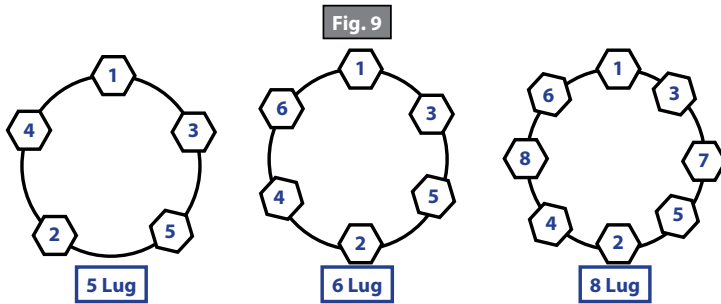

Wheel Torque Requirement Chart				
Wheel Size	Stud Size	Torque Sequence		
		1st Stage	2nd Stage	3rd Stage
14"	1/2"	20-25 ft-lbs (27-34 Nm)	50-60 ft-lbs (68-81 Nm)	90-120 ft-lbs (122-163 Nm)
15"	1/2"	20-25 ft-lbs (27-34 Nm)	50-60 ft-lbs (68-81 Nm)	90-120 ft-lbs (122-163 Nm)
16"	1/2"	20-25 ft-lbs (27-34 Nm)	50-60 ft-lbs (68-81 Nm)	90-120 ft-lbs (122-163 Nm)
16.5" x 6.75"	1/2"	20-25 ft-lbs (27-34 Nm)	50-60 ft-lbs (68-81 Nm)	90-120 ft-lbs (122-163 Nm)
16"	9/16"	20-25 ft-lbs (27-34 Nm)	50-60 ft-lbs (68-81 Nm)	90-120 ft-lbs (122-163 Nm)
16.5" x 6.75"	9/16"	20-25 ft-lbs (27-34 Nm)	50-60 ft-lbs (68-81 Nm)	90-120 ft-lbs (122-163 Nm)
16" Dual and 17.5" Cone Nut	5/8"	50-60 ft-lbs (68-81 Nm)	100-120 ft-lbs (136-163 Nm)	190-210 ft-lbs (258-285 Nm)
16" Dual and 17.5" Flange Nut	5/8"	50-60 ft-lbs (68-81 Nm)	150-200 ft-lbs (203-271 Nm)	275-325 ft-lbs (373-441 Nm)
14.5" Demount	1/2"	Tighten sequentially to 85-95 ft-lbs (115-129 Nm)		

**⚠ WARNING**

**Proper and accurate torque MUST be maintained to prevent wheels from loosening, studs from cracking and/or breaking or other possible hazardous breakage resulting in serious injury or death.**

- 4. Wheel lug nuts should be torqued before first road use and after each wheel removal.
  - A. Check and re-torque wheel lug nuts after 10, 25 and 50 miles (16, 40 and 80 km). A periodic check during regular service is recommended.







Tires

Prior to mounting tires onto wheels, do as follows:

- 1. Make sure rim size and contour are approved by the Tire and Rim Association Yearbook or the tire manufacturer's catalog.
- 2. Verify tire load rating.
  - A. If the load is not evenly distributed across all tires, use the tire rated for the heaviest wheel position.
- 3. Consult the Rubber Manufacturers Association or the tire manufacturer's guidelines for wheel mounting procedures.

Tire pressure is very important to promoting tire life and performance. Tire pressure should always be in accordance with the manufacturer's recommended pressure rating for any given load. Check tire pressure as follows:

- 1. Always check tire pressure cold before operation.
- 2. Do not bleed air from tires when they are hot.

Tire Tread Wear Pattern Chart		
What Is Happening?	Why?	What Should Be Done?
Center Wear 	Over-inflation	Adjust pressure to particular load per tire catalog.
Edge Wear 	Under-inflation	Adjust pressure to particular load per tire catalog.
Side Wear 	Loss of camber or overloading	Make sure load does not exceed axle rating. Call Lippert Service & Warranty to advise.
Toe Wear 	Incorrect Toe-in	Call Lippert Service & Warranty to advise.
Cupping 	Out-of-balance	Check bearing adjustment and balance tires.
Flat Spots 	Wheel lockup and tire skidding	Avoid sudden stop if possible and adjust brakes.

- 3. Check inflation pressure weekly during use to ensure maximum tire and tread life.
- 4. Inspect for tire tread wear patterns that may indicate serious wheel alignment or excessive load limit issues. Refer to the Tire Tread Wear Pattern Chart.

**NOTE:** Tire wear should be checked frequently. Once a tire wear pattern is established, stopping becomes difficult, even when the underlying cause is corrected.

## Introduction to Troubleshooting

The following section is a guideline for ensuring operation of your braking system. The safety of you, those traveling with you and those sharing the road is paramount and it starts with the ability to safely stop the tow vehicle and the towed vehicle.

### Troubleshooting

Most brake malfunctions can be corrected by utilizing the Troubleshooting Chart. Mechanical failure is the most common form of malfunction, however, if the brake system fails and it's not mechanical, it is usually electrical. A Voltmeter and Ammeter are essential tools to diagnosing these problems.

Mechanical problems are mostly self-evident; something is bent or broken. Consult the Troubleshooting Chart to determine the probable cause and corrective actions for a variety of issues with the braking system.

Remember to use only Lippert replacement parts on these systems. Consult the Limited Warranty or call our Service Department for any other related issues.

### Troubleshooting Chart

**NOTE:** If all trailer lights and brakes do not work, check your wiring plug connection (Wiring Diagram, Fig. 13). Make sure the ball is making solid contact with the coupler (that is how a trailer is grounded). Too much grease or not using dielectric grease on the ball and coupler can cause this to happen.

### Measuring Voltage

The Braking System voltage is measured at the two lead wires of the magnet on any brake. Use the pin probes inserted through the insulation of the lead wires. To ensure that the battery is indicating a full charge, the towing vehicle engine should be running with the trailer coupler connected when checking the voltage.

Voltage in the system should begin at 0 volts and, as the brake pedal of the tow vehicle is applied, voltage will gradually increase to about 12 volts. If the system does not indicate at least 12 volts, problems may occur in the wiring of the system, the battery or alternator of the tow vehicle.

When the brakes are applied, a gradual increase in voltage is preferable to a quick increase to 12 volts. A gradual increase in voltage ensures smooth and firm trailer braking. A quick increase in voltage will cause the braking system to feel like the trailer is grabbing too quickly.

Taking a voltage reading is usually done with probes inserted into the wire connector (Fig. 10).

### Measuring Amperage

Braking System amperage is the amount of current flowing through the system when all magnets have been energized. Amperage will change proportionately with voltage. To ensure the battery is fully charged, the tow vehicle engine should be running with the trailer coupler connected when checking the voltage.

If a resistor is used in the brake system, it **MUST** be set at zero or bypassed completely to obtain the maximum amperage reading. Individual amperage draw can be measured by inserting the ammeter in the line at the magnet you want to check. Disconnect one of the magnet lead wire connectors and attach the ammeter between the two wires. Consult Amperage Chart for normal amp readings.

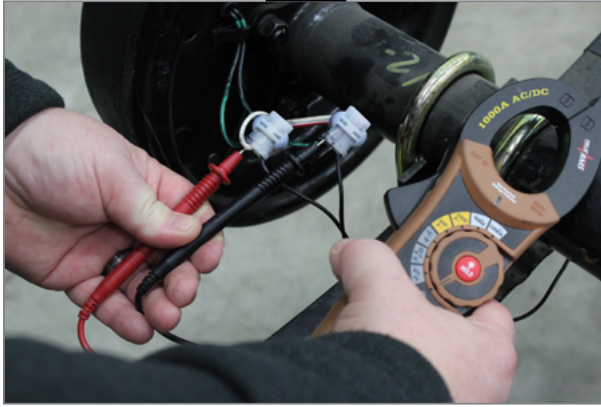
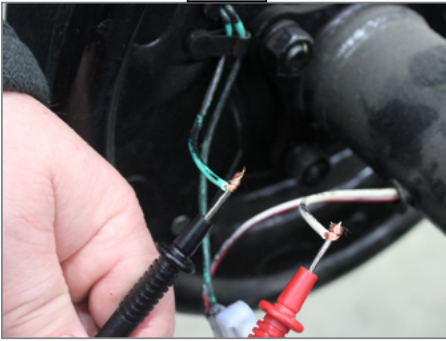
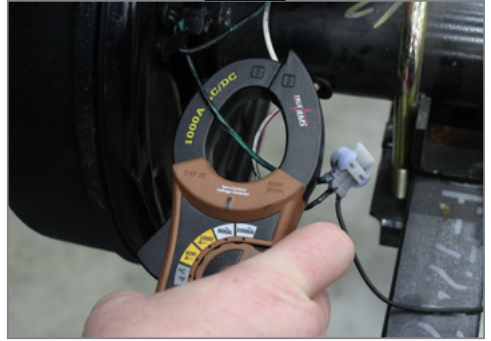
**Fig. 10****Fig. 11****Fig. 12**

Make sure that the wires are properly reconnected and sealed after testing is completed. Testing for amperage can be done with probes (Fig. 11) or alligator clips on the leads or an amp clamp (Fig. 12).

### Amperage Chart

Amperage Chart			
Amps/Magnet	Two Brakes	Four Brakes	Six Brakes
3.0	6.0	12.0	18.0

Low or no voltage are the most common problems with the Braking System. Amperage at the brakes is also a relatively common issue. Common causes of these conditions are:

1. Low quality electrical connections.
2. Open circuits.
3. Insufficient wire gauge. (Reference Trailer Wire Gauge chart.)
4. Broken wires.
5. Blown fuses (fusing of brakes is not recommended).
6. Short circuits (indicated by high amperage).

Trailer Wire Gauge Chart		
Wire Gauge and Type	Number of Axles	Length of Run
16 Ga Stranded Copper	1	N/A
14 Ga Stranded Copper	2	Under 30ft. (9.1m) from hitch to center of axles
12 Ga Stranded Copper	2 or 3	Over 30ft. (9.1m) from hitch to center of axles

Possible causes of shorts are:

1. Shorted magnet coils.
2. Bare wires contacting a grounded object.

Finding the cause of a short circuit in the system is done by isolating one section at a time. If the high amperage reading drops to zero by unplugging the trailer, then the short is in the trailer. If the amperage reading remains high with all the brake magnets disconnected, the short is in the trailer wiring.

All electrical troubleshooting procedures should start at the controller. Most complaints regarding brake harshness or malfunction are traceable to improperly adjusted or nonfunctional controllers. See your controller manufacturer's data for proper adjustment and testing procedures. For best results, all the connection points in the brake wiring should be sealed to prevent corrosion. Loose or corroded connectors will cause an increase in resistance which reduces the voltage available for the brake magnets.

**Troubleshooting Chart**

What Is Happening?	Why?	What Should Be Done?
No brakes	Open circuits	Find and correct
	Short circuits	Test and correct
	Severe under-adjustment	Adjust brakes
Weak brakes	Grease or oil on magnets or linings	Clean or replace
	Corroded connections	Clean and correct cause of corrosion
	Worn linings or magnets	Replace
	Scored or grooved brake drums	Machine or replace
	Improper synchronization	Correct
	Under-adjustment	Adjust brakes
	Glazed Linings	Re-burnish or replace
Locking brakes	Under-adjustment	Adjust brakes
	Improper synchronization	
	Loose, bent or broken brake components	Test and correct
	Out-of-round brake drums	Machine or replace
	Insufficient wheel load	Adjust system resistor and synchronize
Intermittent brakes	Broken wires	Test and correct
	Loose connections	Repair or replace
	Faulty ground	Find and repair
Brakes pull to one side	Wrong magnet lead wire color	Adjust
	Incorrect adjustment	Correct
	Grease or oil on linings or magnets	Clean or replace
	Broken wires	Find and repair
	Bad connections	Find and repair
Harsh brakes	Under-adjustment	Adjust brakes
	Improper synchronization	Correct
Noisy brakes	Under-adjustment	Adjust brakes
	Lack of lubrication	Lubricate
	Broken component	Replace component
	Incorrect brake components	Correct
Surging brakes	Grease or oil on linings or magnets	Clean or replace
	Out-of-round or cracked brake drums	Machine or replace
Dragging brakes	Over-adjustment	Readjust
	Out-of-round brake drums	Machine or replace
	Incorrect brake components	Replace
	Loose, bent or broken brake components	Replace
	Faulty breakaway switch	Repair or replace
	Loose wheel bearing adjustment	Adjust
	Bent spindle	Replace Axle

## Maintenance Schedule

Item	Function Required	3,000 Miles	12 Months / 36,000 Miles (Whichever comes first)
Brakes	Test that they are operational.	At Every Use	
Oil Level	Check oil level in hubs, if equipped.	At Every Use	
Brake Adjustment	Adjust to proper operating clearance. Not required for self-adjusting brakes.	◆	
Brake Magnets	Inspect for wear and current draw.		◆
Brake Linings and Pads	Inspect for wear or contamination.		◆
Hub/Drum and Rotors	Inspect for abnormal wear or scoring.		◆
Wheel Bearing	Inspect for corrosion or wear. Clean and repack.		◆
Seals	Inspect for leakage. Replace if removed.		◆
Springs	Inspect for wear, loss of arch.		◆
Suspension Parts	Inspect for bending, loose fasteners, wear.		◆
U-bolts	Tighten to specified torque values		◆

# Wiring Diagram

Fig. 13

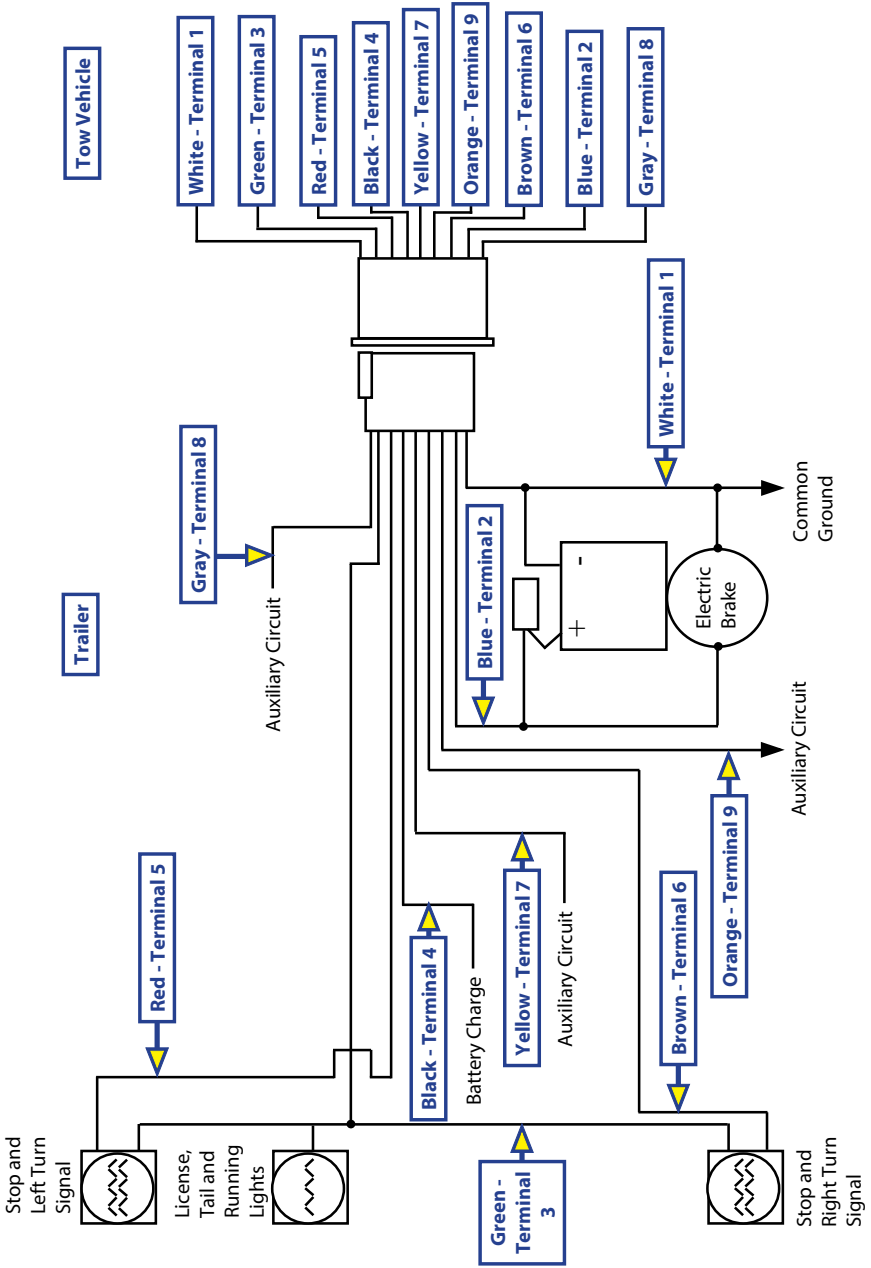
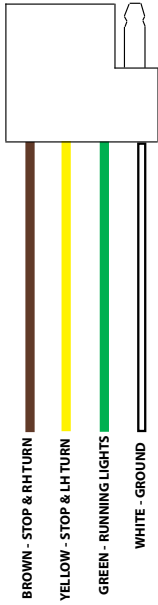
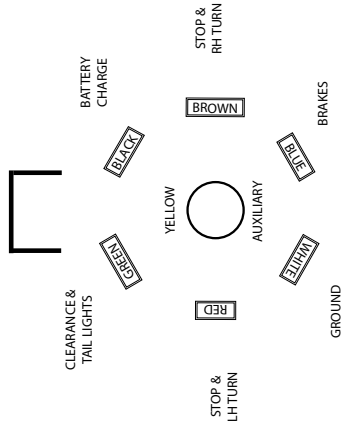

Fig. 14



**TRAILER LIGHTS PIGTAIL - DOES NOT OPERATE BRAKES**

**7-PIN COUPLER**



**9-PIN COUPLER**

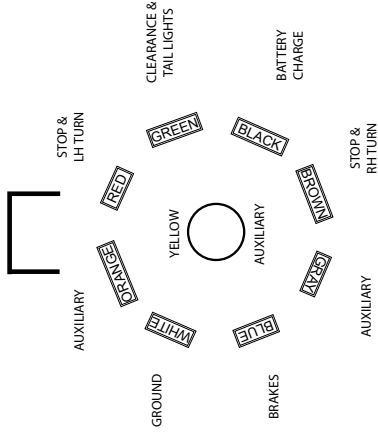

**TRAILER BRAKE AND LIGHT COUPLER - OPERATES BRAKES**

## Storage

### Storage Preparation

If your trailer is to be stored for an extended period of time, the trailer will need to be prepared prior to going into storage. Follow these guidelines to set up your trailer for storage:

1. If the trailer has an emergency breakaway battery, remove it and store it inside, out of the weather. Charge the battery at least every 90 days.
2. Jack up the trailer and place jack stands under the trailer frame so that the weight will be off the tires. Follow trailer manufacturer's guidelines to lift and support the trailer.
3. Lubricate mechanical moving parts such as the hitch, and suspension parts, that are exposed to the weather.
4. In the case of boat trailer axles that are subject to repeated immersion, remove brake drums; clean, dry and re-lubricate moving brake components; inspect bearings - clean and re-lubricate.



**Lift the trailer by its frame and never the axle or suspension. Do not go under the trailer unless it is properly supported by jack stands. Unsupported trailers can fall causing death or serious injury.**

### Extended Storage Inspection Procedures

Trailer should remain on jack stands during this procedure:

1. Remove all wheels and hubs or brake drums. Reinstall drum to same spindle and brake from which it was removed.
2. Inspect suspension for wear.
3. Check tightness of hanger bolt, shackle bolt, and U-bolt nuts of the suspension for correct torque.
4. Check brake linings, brake drums and armature faces for excessive wear, scoring, damage or corrosion.
5. Check brake magnets with an ohmmeter. The magnets should check 3.2 ohms. If shorted or worn excessively, they must be replaced.
6. Lubricate all brake moving parts using a high temperature brake lubricant.
7. Remove any rust from braking surface and armature surface of drums with fine emery paper or crocus cloth. Be sure to protect bearings from contaminating dust.
8. Inspect oil or grease seals for wear or nicks. Replace if necessary. Using the [Trip Preparation Checklist](#) before starting a trip with your trailer is highly recommended. Allow plenty of time prior to any trip for any service or repairs that may need to be done before using the trailer.
9. Lubricate hub bearings.
10. Reinstall hubs and adjust bearings.
11. Mount and tighten wheels.

**NOTE:** Avoid getting any grease or oil on brake linings and pads or magnet surfaces.

### **Trip Preparation Checklist**

The following checklist offers several guidelines to prolonging the quality of your running gear and will provide trustworthy and safe trailering for years to come.

Using the following checklist before starting a trip with your trailer is highly recommended. Allow plenty of time prior to any trip for any service or repairs that may need to be done before using the trailer.

1. Maintenance schedule should be current.
2. Inspect hitch for corrosion, lubrication and wear.
3. Inspect safety chains for rust and wear. Engage chains and breakaway switch actuating chain securely. Breakaway battery should be fully charged.
4. Electronic coupler must be secure. Run check on all lights and brake engagement and synchronization. Refer to Figures 13 and 14.
5. Load trailer with 10% of total weight on the hitch end of trailer. Smaller trailers' front end load should be increased to 15%.
6. Do not overload. Consult your trailers i.d. plate for gross vehicle weight restrictions.
7. Tires should be inflated to manufacturer's specifications. Inspect tires for any damage or wear.
8. Inspect lug nuts/bolts. All should be torqued to specifications. Refer to Wheel Torque Requirement Chart for torque limits.
9. Check torque of hanger bolt, shackle bolt, and U-bolt nuts on suspension.
10. Check that your trailer is towing level. Adjust hitch height if necessary to level trailer.

## Limited Warranty

### LIPPERT COMPONENTS® AXLE LIMITED WARRANTY (NORTH AMERICAN OEM SALES)

This Axle Limited Warranty ("Warranty") outlines applicable coverage and claim procedures for Products incorporated into units or trailers retail sold after January 1, 2017, as defined herein, sold by Lippert Components, Inc. or its subsidiaries or affiliates (the direct seller being the only warrantor referenced herein as "Warrantor", "we", "us" or "our").

**Coverage.** Subject to these terms, we warrant ONLY to you, the original equipment manufacturer ("OEM", "you" or "your"), that the axles and suspension systems that we manufacture, distribute and/or sell to you that are not already covered by a separate written warranty from another manufacturer (the "Product(s)") will be free from defects in materials and workmanship at the time of sale. We will honor this Warranty for the applicable period from the date of retail purchase, and cover only Products sold and used in the United States and Canada. The Warranty period shall be as follows:

**Limited 1 Year Warranty** – grease and oil seals for all Products.

**Limited 6 Year Warranty** – spring axles and suspension systems.

**Limited 11 Year Warranty** – torsion axles.

**Service.** For Products having a covered defect within the Warranty period, we will, in our sole and absolute discretion, repair or replace the Product with a new or refurbished component, or provide a pro rata refund of that portion of the Product. Labor will be allowed if a designated flat rate time is outlined by us and will be limited to the published flat rate amount. There is no other warranty.

**Notice.** No remedy will be required or offered unless we receive written notice of a claimed defect. You must make any claim of defect, including without limitation under this Warranty, in writing, with full particulars, promptly after the defect was or reasonably should have been discovered, and in any event no later than sixty (60) days of its discovery. In the event of any accident, injury to person, damage to property, or other loss involving a Product, you must notify us in writing within thirty (30) days of the incident or within ten (10) days of notification to you, whichever is earlier. In the event of any survey, test, or inspection to be conducted on a Product, you must notify us in writing immediately so that we, at our sole election, may participate in that activity or conduct our own survey, test, or inspection in advance. Your written notice must describe the defect, provide the customer's name and address, state the location of the Product, and provide us full particulars (see below). As a condition of coverage, we must be provided access to the original Product for inspection, testing, or other work at our discretion. The Product must remain unmodified. We will not consider any claims for Products (or any components thereof) that are not in their original form. Failure to give us proper or timely notice of a claimed defect, or failure to return the defective Product, or performing any modification, self-help, or alteration of the Product, without our prior written approval, will constitute an absolute waiver and release of all your claims and rights under this Warranty.

**Transferability.** THIS WARRANTY IS NOT ASSIGNABLE OR TRANSFERABLE. THIS WARRANTY EXTENDS ONLY TO YOU, THE ORIGINAL OEM PURCHASER PURCHASING A PRODUCT DIRECTLY FROM WARRANTOR'S FACILITIES, AND WILL NOT BE CONSTRUED TO EXTEND TO ANY THIRD-PARTY, INCLUDING WITHOUT LIMITATION THE ULTIMATE RETAIL PURCHASER OR CONSUMER OF AN END PRODUCT. YOU MAY NOT REPRESENT TO ANYONE, INCLUDING YOUR CUSTOMER OR AN END CONSUMER THAT THIS WARRANTY EXTENDS TO THEM.

**Limitations.** THERE IS NO WARRANTY OF MERCHANTABILITY OR FITNESS FOR A PARTICULAR PURPOSE, TO THE FULL EXTENT DISCLAIMER IS PERMITTED BY LAW. IN ANY EVENT, ANY IMPLIED WARRANTY THAT MAY ARISE BY LAW IS LIMITED IN DURATION TO THE TERM HEREIN AND TO THE COVERED PRODUCTS. THE REPAIR, REPLACEMENT, OR REFUND PROVIDED HEREIN IS EXCLUSIVE AND IN LIEU OF ALL OTHER REMEDIES. EXCEPT AS PROVIDED IN THIS WARRANTY, ALL PRODUCTS ARE BEING SOLD "AS IS" AND "WITH ALL FAULTS." ALL RISKS AS TO PRODUCT QUALITY OR PERFORMANCE NOT CONTEMPLATED BY THIS WARRANTY WILL BE BORNE EXCLUSIVELY BY YOU, THE PURCHASER. IF A PRODUCT PROVES DEFECTIVE AFTER ITS PURCHASE, YOU, NOT US, ASSUME THE ENTIRE COST OF ALL NECESSARY SERVICING OR REPAIR THAT IS NOT COVERED UNDER THIS WARRANTY. IN NO EVENT WILL WE BE LIABLE FOR COSTS OF REMOVAL OR REINSTALLATION OF THE PRODUCTS, OR ANY EXPENSE RELATED TO REINSTALLATION. WE WILL HAVE NO LIABILITY TO ANYONE FOR CONSEQUENTIAL, SPECIAL, INCIDENTAL, INDIRECT, EXEMPLARY, OR PUNITIVE DAMAGES OF ANY KIND WHATSOEVER, INCLUDING WITHOUT LIMITATION PROPERTY DAMAGE, LOST PROFITS, LABOR COSTS, OR ANY OTHER PECUNIARY DAMAGE, WHETHER DUE TO ANY DEFECT IN THE PRODUCTS, BREACH, DELAY, NON-DELIVERY, NON-PERFORMANCE, RECALL, OR ANY OTHER REASON. ALL CLAIMS FOR NEGLIGENCE AND FOR FAILURE OF ESSENTIAL PURPOSE ARE EXPRESSLY WAIVED AND RELEASED. UNDER NO CIRCUMSTANCES WILL OUR LIABILITY FOR ANY DEFECT IN THE GOODS, WHETHER BASED ON CONTRACT, TORT, WARRANTY, OR ANY OTHER THEORY, EXCEED THE PURCHASE PRICE OF THE PRODUCTS. THERE ARE NO THIRD-PARTY BENEFICIARIES TO THE WARRANTY'S TERMS. YOU WAIVE ANY RIGHT TO A JURY TRIAL AND CLASS ACTION RELATING TO THIS WARRANTY, AND MAY NOT JOIN OR CONSOLIDATE CLAIMS AS A REPRESENTATIVE OF A CLASS ACTION OR IN A PRIVATE ATTORNEY GENERAL CAPACITY. THESE PROVISIONS PROVIDE SPECIFIC LEGAL RIGHTS AND LIMITATIONS. SOME MAY NOT APPLY BASED ON STATE OR FEDERAL LAW, AND OTHER LEGAL RIGHTS MAY EXIST.

**Exclusions.** This Warranty only covers the Products. Due to the intended use of our Products, any and all items and components not sold by us but attached to, incorporated into, or using our Products carry NO WARRANTY WHATSOEVER from us regardless of circumstance. We will not be liable for any defects, whether due to workmanship, materials or any other reason whatsoever, for those items and components not sold by us. This Warranty also does not cover customer instruction, installation and labor (except as provided herein), parts supplied by others, abuse, misuse, neglect, improper installation or improper repair by anyone other than us, improper usage, overloading, accidents, unreasonable use, improper loading, improper operation, improper repair, improper

maintenance, normal wear and tear, normal wear components (including bolts, nuts, shackles, and riding enhancement products) color fade, mold, mildew, corrosion, rust formation, modifications, or attempted repair by anyone other than a qualified repair facility. This Warranty does not cover chemical damage caused by acids, fuel, oil, or other chemicals. Use of our Products in or as part of a unit in a rental fleet, or for a commercial or industrial purpose, voids your rights under this Warranty. The Warranty also does not extend to and does not cover defects caused by the following:

The connecting of brake wiring to the trailer wiring or trailer wiring to the towing vehicle wiring.  
The attachment of the axles and running gear to the chassis/frame.

Any and all damage caused by or related to any alteration of the axle or running gear including welding supplemental brackets to the axle.

Improper alignment.

Unreasonable use, including failure to perform reasonable and necessary maintenance in accordance with our operations and service manuals with proof of such maintenance (including required maintenance after prolonged storage.)

Use of an axle on a unit/trailer other than the unit/trailer to which it was originally mounted.

Improper torque values and torquing of wheel nuts not in accordance with our operations manual.

**Indemnity.** You agree to indemnify and hold us, as well as our officers, agents, employees, and representatives, harmless from and against all claims, causes of action, liabilities, losses, damages, judgments, and proceedings, whether based in contract, quasi-contract, subrogation, tort, strict liability, or any other legal or equitable theory, including without limitation all expenses, costs, damages or injury to person or property, and attorney fees incident thereto, arising from or relating to your handling, storage, transportation, possession, processing, fabrication, resale, or any other activity involving the Products after delivery, or relating to any extension or attempt to extend, assign, transfer, or pass this Warranty through to anyone else. At our request, and subject to our sole discretion to choose our own counsel, you will also defend us from any such claims, causes of action, or proceedings.

**Statute of Limitations.** Any action, lawsuit or other proceeding, under this Warranty or otherwise, related to the Product must be commenced within one (1) year after the earlier of (a) the expiration of the applicable Warranty coverage period, (b) our alleged failure to repair the defect at issue; or (c) the date on which your claim accrues under applicable law. Unless prohibited by law, the performance of repairs will not prevent the limitations period from expiring, nor will any tolling or estoppel doctrine apply. This Warranty does not extend to future performance.

**Applicable Law & Venue.** This Warranty will be governed by and construed in accordance with the laws of the State of Indiana without regard to principles of conflicts of law. Any disagreement, dispute, controversy, or claim arising out of or relating to this Warranty must be submitted to binding arbitration in accordance with the Rules of the American Arbitration Association. Judgment upon the award may be entered in any court having jurisdiction thereof. In the event you bring any claim against us in violation of this Warranty or for claims waived or released under this Warranty, you agree to pay our attorney and paralegal fees and costs to defend such suit.

**Modifications.** We will not be liable for commitments, promises, or agreements made by any employee, agent, or dealer that is not in accordance with this Warranty. The current warranties and terms outlined on the Warrantor's website ([www.lc1.com](http://www.lc1.com)) applicable on the date of purchase take precedence over any other warranties, whether oral or written. We reserve the right to alter our warranties from time to time, as the laws and our business needs and industry change. Any conditions or exceptions that may be stated in any communication or document to us from any entity or individual, including but not limited to the retail purchaser or consumer, shall be of no effect unless specifically agreed to in writing and hand-signed by our authorized representative.

**Miscellaneous.** Any legally or otherwise invalid provision hereof will be considered severable, with all remaining provisions enforceable. We have all rights and remedies given to sellers by applicable law, and our rights and remedies are cumulative and may be exercised from time to time. No waiver by us of any provision of this Warranty will be effective unless in writing, nor will it operate as a novation or waiver of any other provision or affect our right to exercise thereafter any right or remedy. We will not lose any right because we have not exercised that right in the past.

**For questions and claims, contact Lippert Components, Inc., Attn. Warranty Dept., 1902 West Sample Street, South Bend, Indiana 46619. The telephone number to obtain the name and address of the service and repair facility nearest you is 1-574-537-8900. You may also email your claim to [customerservice@lc1.com](mailto:customerservice@lc1.com). To process your claim, we will need the following information: vehicle identification number (VIN), date of manufacture, date of purchase, the make and full model number, pictures of alleged defect, and description of alleged defect. Please include this information with any correspondence and have this information available when you call.**



The contents of this manual are proprietary and copyright protected by Lippert. Lippert prohibits the copying or dissemination of portions of this manual unless prior written consent from an authorized Lippert representative has been provided. Any unauthorized use shall void any applicable warranty. The information contained in this manual is subject to change without notice and at the sole discretion of Lippert. Revised editions are available for free download from [lippert.com](http://lippert.com).

Please recycle all obsolete materials.

For all concerns or questions, please contact Lippert  
Ph: 432-LIPPERT (432-547-7378) | Web: [lippert.com](http://lippert.com) | Email: [customerservice@lci1.com](mailto:customerservice@lci1.com)