



**TITAN LEVELING  
SYSTEMS™ FOR  
5TH WHEEL  
OWNER'S MANUAL**



Scan for product support

# TABLE OF CONTENTS

<b>Introduction</b>	<b>2</b>
Components	2
<b>Additional Information Sources</b>	<b>3</b>
<b>Safety</b>	<b>3</b>
<b>Preparation</b>	<b>5</b>
<b>Prior to Operation</b>	<b>5</b>
<b>Operation</b>	<b>5</b>
Basic Touchscreen Operation	5
Controller Lockout	6
Operating the Touchscreen	7
Basic Jack Operation	8
Unhitching Instructions	8
Auto Level Sequence	9
Hitch Recognition	10
<b>Options</b>	<b>11</b>
Current Level	11
Manual Mode	11
Entering a Custom Set Point	12
Light Controls	13
Dark Theme	13
<b>Smart Device Pairing</b>	<b>14</b>
<b>Troubleshooting</b>	<b>15</b>
Error Messages	15
Set Point Calibration	18
Manual Override	18
<b>Maintenance</b>	<b>19</b>
Fluid Recommendation	19
Preventive Maintenance	19
<b>Wiring Diagram</b>	<b>20</b>
<b>Plumbing Diagram</b>	<b>21</b>

## Introduction

The Titan Leveling Systems™ Hydraulic Leveling System includes six points of contact utilizing aluminum jacks and a multi-valve system. A 12V DC electric motor drives a hydraulic pump that moves fluid through a system of hoses, fittings and jacks to level and stabilize the trailer.

Mechanical portions of the Titan Leveling Systems are replaceable.

## Components

1. Jacks
  - A. Rated at a lifting capacity for the trailer.
  - B. Standard 9-inch diameter (63.5 square inch) foot pad on a ball swivel for maximum surface contact.
  - C. Operational Powered from a 12V DC Motor/Pump assembly
2. Motor/Pump Assembly
  - A. 12V DC motor
  - B. Hydraulic fluid reservoir tank
  - C. Control valve manifold
  - D. Solenoid valve
3. System Controls
  - E. Touchscreen can be operated in manual mode or fully automatic mode.

## Additional Information Sources

Additional information about this product can be obtained from [lci1.com/support](http://lci1.com/support) or by downloading the free LippertNOW app. The app is available on Apple App Store® for iPhone® and iPad® and also on Google Play™ for Android™ users.

App Store®, iPhone®, and iPad® are registered trademarks of Apple Inc.  
Google Play™ and Android™ are trademarks of Google Inc.

**NOTE:** Images used in this document are for reference only when assembling, installing and/or operating this product. Actual appearance of provided and/or purchased parts and assemblies may differ.

For information on the assembly or individual components of this product, please visit:  
<https://support.lci1.com/lippert-towable-titan-leveling-system>.

## Safety

Read and understand all instructions before installing or operating this product. Adhere to all safety labels.

This manual provides general instructions. Many variables can change the circumstances of the instructions, i.e., the degree of difficulty, operation and ability of the individual performing the instructions. This manual cannot begin to plot out instructions for every possibility, but provides the general instructions, as necessary, for effectively interfacing with the device, product or system. Failure to correctly follow the provided instructions may result in death, serious personal injury, severe product and/or property damage, including voiding of the Lippert limited warranty.

### **WARNING**

**The "WARNING" symbol above is a sign that a procedure has a safety risk involved and may cause death or serious personal injury if not performed safely and within the parameters set forth in this manual.**

### **WARNING**

**Failure to follow instructions provided in this manual may result in death, serious personal injury and/or severe product and property damage, including voiding of the component warranty.**

### **WARNING**

**Be sure to park the trailer on solid, level ground. Chock all tires. Clear all jack landing locations of debris and obstructions. Locations should also be free of depressions. When parking the trailer on surfaces other than concrete or blacktop (such as gravel or dirt), it is recommended to use load distribution pads under each jack to prevent sinking and/or damage. People and pets should be clear of the trailer while operating the leveling system. The leveling system is not intended to lift all the tires off the ground. However, in some leveling conditions, the tires on the low side may lift off the ground in order to achieve a level position. If the distance between the ground and the tire is greater than one inch, additional safety devices such as jack stands and/or leveling pads under the tires should be used to prevent the risk of injury caused by unexpected retraction of the jacks.**

**⚠ WARNING**

The use of the Lippert Titan Leveling Systems 5th Wheel Leveling System to support the trailer for any reason other than which it is intended is prohibited by the Lippert Warranty. The 5th Wheel **MUST** be supported per manufacturer's recommendations before working underneath. The Lippert Titan Leveling Systems 5th Wheel Leveling System is designed as a leveling system only and should not be used for any reason to provide service under the trailer, e.g. changing tires or servicing the leveling system. Any attempts to change the tires, or perform other service, while 5th Wheel is supported solely by the Lippert Titan Leveling System could result in death or serious personal injury, severe product and/or property damage.

**⚠ WARNING**

Lippert recommends that a trained professional be employed to change the tires on the trailer. Any attempts to change tires or perform other service while trailer is supported by the Lippert Titan Leveling Systems 5th Wheel Leveling System could result in damage to the trailer and/or cause serious injury or death.

**⚠ WARNING**

A fluid leak within a highly pressurized hydraulic system can cause serious skin-penetrating injuries. Wear appropriate Personal Protective Equipment (PPE), such as long sleeves, gloves, protective eye wear or a full face shield, when performing service or maintenance to the 5th Wheel.

**⚠ CAUTION**

The "CAUTION" symbol above is a sign that a safety risk is involved and may cause personal injury and/or product or property damage if not safely adhered to and within the parameters set forth in this manual.

**⚠ CAUTION**

Always wear eye protection when performing service, maintenance or installation procedures. Other safety equipment to consider would be hearing protection, gloves and possibly a full face shield, depending on the nature of the task.

**⚠ CAUTION**

Moving parts can pinch, crush or cut. Keep clear and use caution.

## Preparation

1. Make sure the 5th Wheel is parked on a reasonably level surface.
2. Clear all jack landing locations of debris and obstructions. Locations should also be free of depressions.
3. When parking the 5th Wheel on extremely soft surfaces, utilize load distribution pads under each jack.
4. Make sure the battery of the 5th Wheel is fully charged or that the 5th Wheel is plugged into shore power prior to attempting to operate the system.

**NOTE:** Titan Leveling Systems require a minimum of 12V DC from the battery for proper operation.

## Prior to Operation

The leveling system shall only be operated under the following conditions:

1. The trailer is parked on a reasonably level surface.
2. Make sure all persons, pets and property are clear of the trailer while the LCD 5th Wheel Leveling system is in operation.
3. Make sure the battery of the trailer is fully charged or that the trailer is plugged into shore power prior to attempting to operate the system. The automatic leveling system requires a minimum of 12V DC from the battery for operation.

## Operation

All controls can be operated by the touchscreen on the side of the trailer, and through the OneControl Mobile App for smart devices. The app is available on Apple App Store® for iPhone® and iPad® and also on Google Play™ for Android™ users. The app must first be paired to the trailer. See the Smart Device Pairing section for instructions.

### Basic Touchscreen Operation

1. If latch is present, open the touchscreen by placing a finger underneath the latch (Fig. 1A) and pulling outwards. The door will unlatch (Fig. 2).

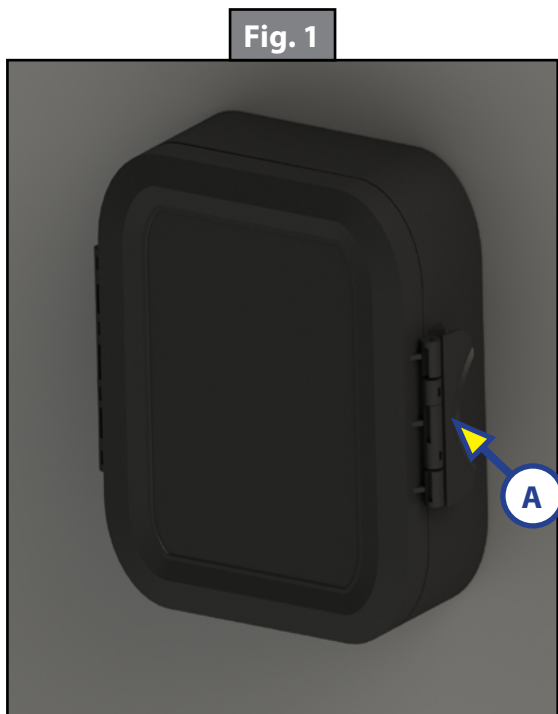

2. Tap the screen to wake the system up.
  3. Upon waking the touchscreen for use, the PIN will need to be entered (Fig. 3).
    - A. **The PIN is 5241.** This can be found on the controller label (Fig. 17)
- NOTE:** The PIN is set from the factory and not able to be changed.
- B. Tapping the question mark (Fig. 3A) will show more information about the PIN.
4. If latch is present, close the touchscreen by closing the door and pressing the latch (Fig. 4A) toward the housing. The latch will snap closed.

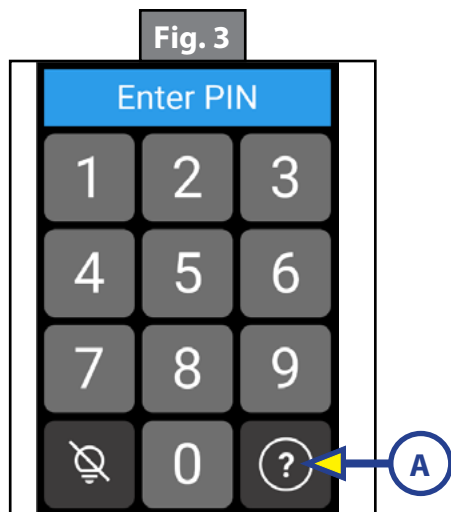

## Controller Lockout

For safety, the leveling controller enters Lockout Mode when it detects the trailer brake has been applied. During Lockout Mode, extending jacks is prevented. Retracting jacks and the auto-retract function are allowed.

1. If an action is attempted that lockout is restricting, an error message will be displayed on the touchscreen (Fig. 4) or the mobile app (Fig. 5) to inform the operator that the action is not allowed.
2. To clear the lockout, enter the correct PIN on the touchscreen while the trailer brake is not active.
  - A. **The default PIN is 5241.** This can be found on the controller label (Fig. 17).

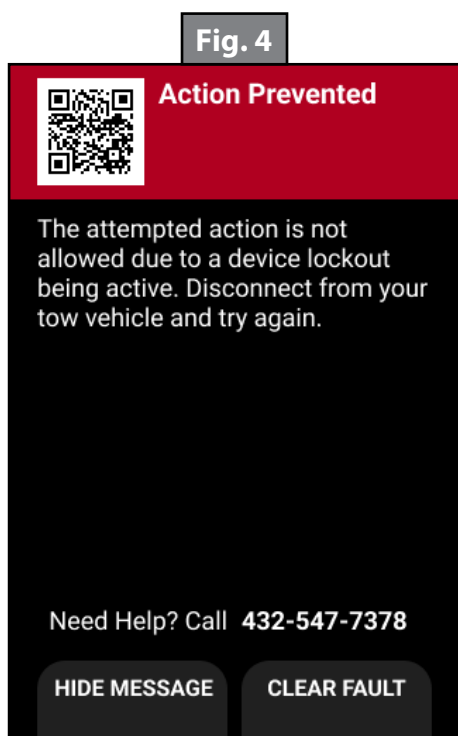

Touchscreen

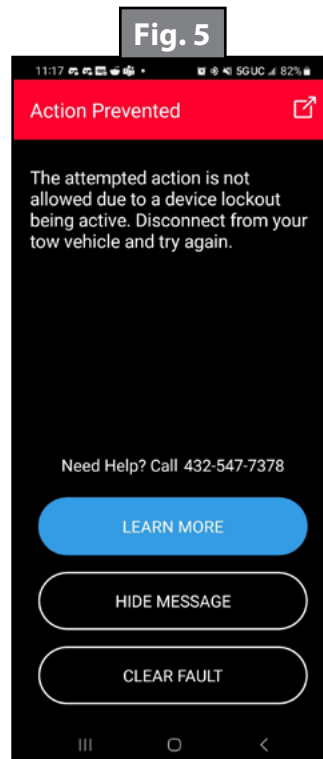

Mobile App

## Operating the Touchscreen

The buttons on the touchscreen can be operated by pressing on the screen, or pressing and holding on the screen. The touchscreen is a pressure-responsive type. This allows the touchscreen to be operated while wearing gloves, and protects the leveling system against accidental operation.

The primary features are shown on three different screens: The ARRIVAL SCREEN, CAMPING SCREEN, and DEPARTURE SCREEN (Fig. 6). For convenience, only the controls primarily used during each phase of camping are shown. To prevent accidental operation, certain controls are grayed-out until other controls have been used.

The OPTIONS menu and JACK LIGHTS controls are available on all three of these screens (Fig. 6).

Fig. 6

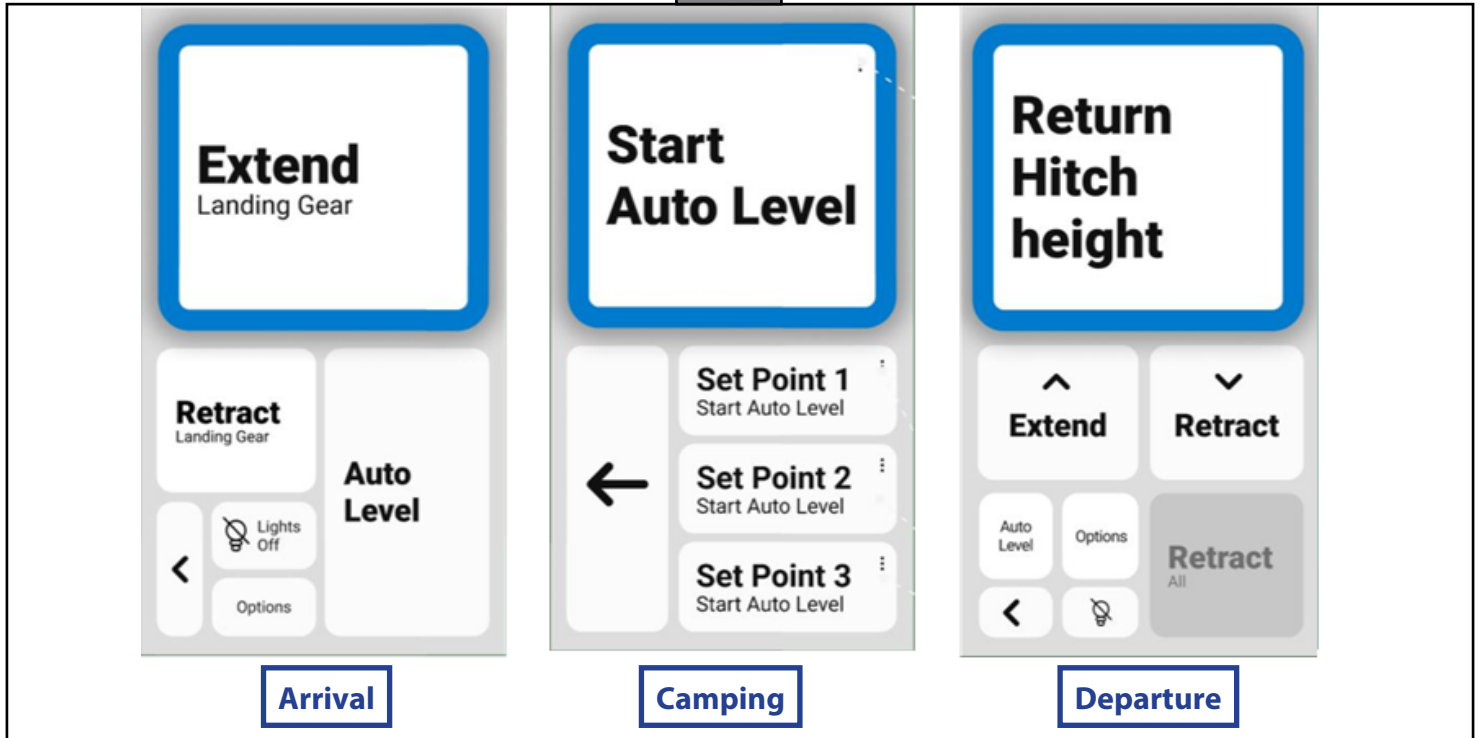

## Basic Jack Operation

1. Landing Gear Jacks
  - A. Landing gear jacks can be operated any time the system is on, but not in AUTO MODE. Press and hold the EXTEND button (Fig. 7A), so that both the front or landing gear jacks can be extended.

**NOTE:** The RETRACT button will be grayed out until the landing gear jacks have been extended.

- B. Press and hold the RETRACT button (Fig. 7B), to retract the landing gear jacks together.
2. All Jacks
  - A. All jacks operate when the system is performing an "AUTO OPERATION" such as AUTO LEVEL, RETURN TO HITCH HEIGHT, or RETRACT ALL.
  - B. In "MANUAL MODE", the corner jacks can be operated independently or in pairs. Middle jacks operate in unison with the same-side rear jack.

**NOTE:** The default is AUTO OPERATION. MANUAL MODE can be selected through the OPTIONS menu.

- C. In "FAULT MODE" all jacks can be operated independently. FAULT MODE is only available when a fault is active.

## Unhitching Instructions

### **⚠ WARNING**

**Be sure to park the trailer on solid, level ground. Chock all tires. Clear all jack landing locations of debris and obstructions. Locations should also be free of depressions. When parking the trailer on surfaces other than concrete or blacktop (such as gravel or dirt), it is recommended to use load distribution pads under each jack to prevent sinking and/or damage. People and pets should be clear of the trailer while operating the leveling system. The leveling system is not intended to lift all the tires off the ground. However, in some leveling conditions, the tires on the low side may lift off the ground in order to achieve a level position. If the distance between the ground and the tire is greater than one inch, additional safety devices such as jack stands and/or leveling pads under the tires should be used to prevent the risk of injury caused by unexpected retraction of the jacks.**

Unhitching from the tow vehicle is done from the ARRIVAL SCREEN (Fig. 6)

**NOTE:** Before unhitching from the tow vehicle, make sure trailer is parked on a level surface and the tires are chocked.

1. Tap the screen to wake the system up.
2. Press EXTEND (Fig. 7A) to extend the landing gear jacks to lift the front of the trailer to take the weight of the 5th wheel off of the hitch.
3. Uncouple the 5th wheel connection on the tow vehicle.
4. Pull the tow vehicle away and park at a safe distance.

**NOTE:** To use the RETURN TO HITCH HEIGHT function later, make sure the front of the RV is above level before pressing the AUTO LEVEL button.

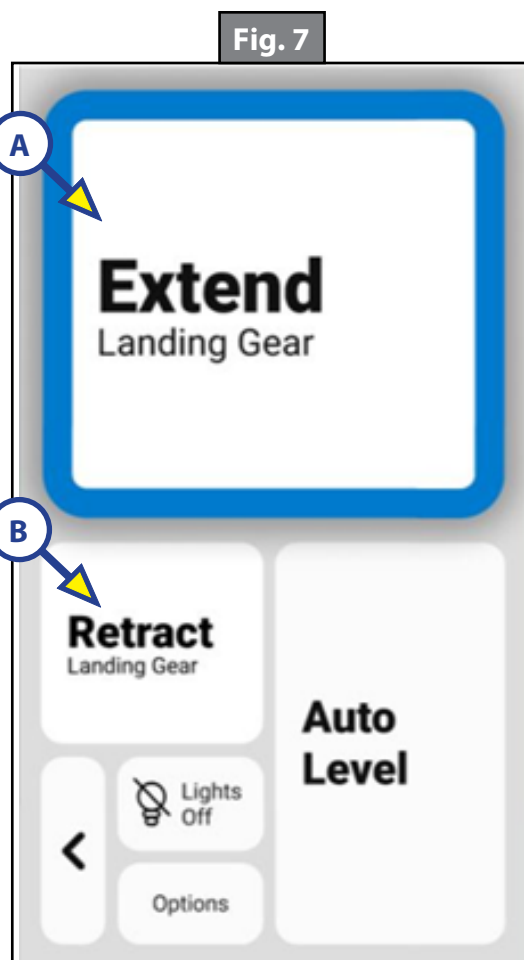

## Auto Level Sequence

1. After unhitching from tow vehicle, from the ARRIVAL SCREEN press AUTO LEVEL (Fig. 8A).

**NOTE:** Pressing any button during an Auto Level sequence will abort the auto leveling cycle.

**NOTE:** In order for the hitch recognition feature to function, the auto level sequence **MUST** be started with the front of the trailer above level.

**NOTE:** You can set up to three custom set points for your leveling system. These will be set to the factory default unless changed.

2. On the CAMPING SCREEN, press START AUTO LEVEL (Fig. 9A), or if you desire a custom set point, press SET POINT 1, 2, or 3 and START (Fig. 9).
3. Front landing gear will retract, lowering the front of the unit below level, stopping, then lifting the front end to level the unit front-to-back.
4. The left side leveling jack extends and raises the roadside of the unit.
5. The right side leveling jack extends and raises the curbside of the unit, beginning side-to-side leveling.
6. The front landing gear extend to complete the leveling cycle.
7. Additional left-to-right or front-to-back leveling may occur, if the controller deems necessary.

**NOTE:** If the auto level sequence does not happen as stated above, check to ensure proper manual function in all zones.

Fig. 8

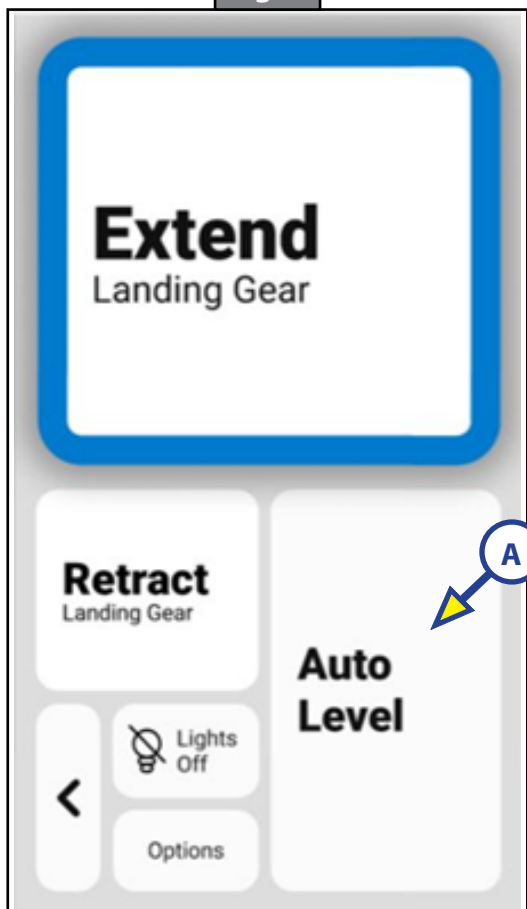
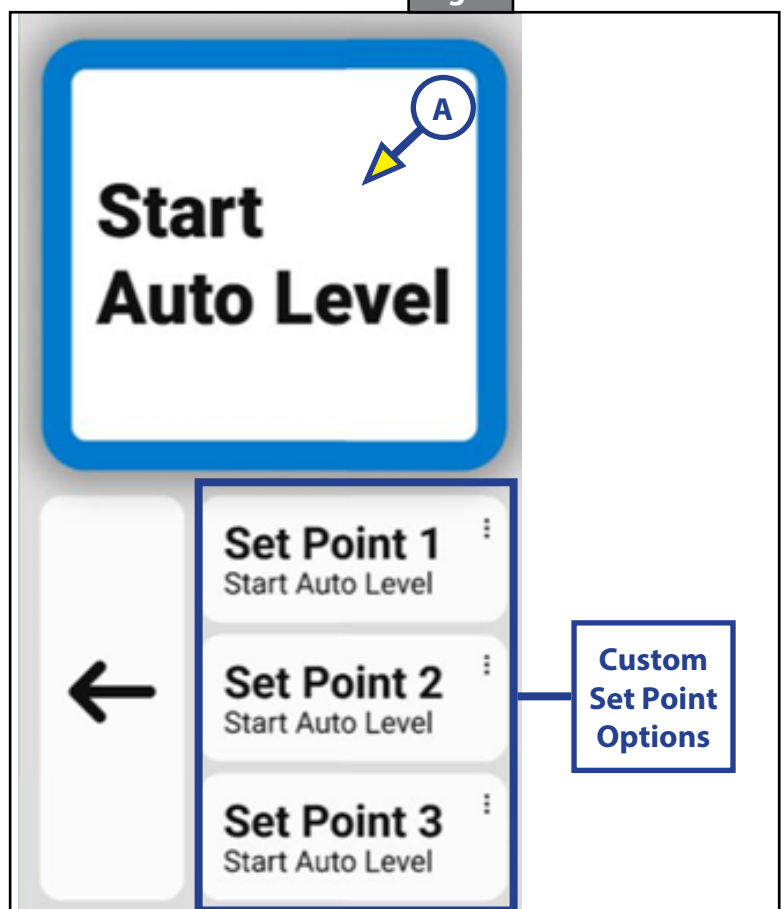

Fig. 9



## Hitch Recognition

1. Tap the screen to turn on the touchscreen.
2. From the DEPARTURE screen (Fig. 10) press RETURN HITCH HEIGHT (Fig. 10A).
3. The front of the trailer will raise to the height where the auto level sequence was started.

**NOTE:** If the auto level sequence was started with the front of the trailer in a below-level condition, the hitch recognition will not function. For hitch recognition to function, the auto level sequence must be started with the front of the trailer above level.

4. Connect tow vehicle and make sure 5th Wheel and hitch are connected and locked.
5. Use the EXTEND (Fig. 10B) and RETRACT (Fig. 10C) buttons to put the weight of the RV onto the tow vehicle.
6. Press RETRACT ALL (Fig. 10D) to automatically retract all the jacks.

**NOTE:** You can stop the automatic RETRACT ALL sequence at any time by pressing the screen.

**NOTE:** A visual inspection of the jacks in the retract position is recommended after completing Auto Retract.

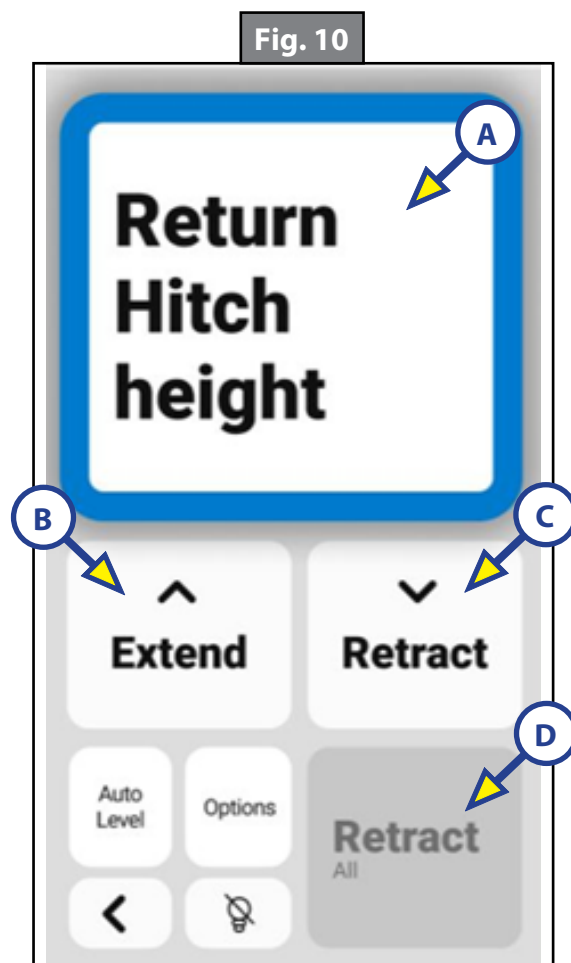

## Options

Press the OPTIONS button (Fig. 11A) to go to the options page (Fig. 12).

**NOTE:** ARRIVAL screen is shown (Fig. 11) for reference. The OPTIONS button is also available on the DEPARTURE screen (Fig. 10).

## Current Level

Current Level (Fig. 12A) displays the current angle sensed by the controller, relative to the factory set point.

## Manual Mode

MANUAL MODE (Fig. 12B) allows for the corner jacks to be operated independently or in pairs. Middle jacks operate in unison with the same-side rear jack.

1. To enter MANUAL MODE, press OPTIONS, and select MANUAL MODE (Fig. 12B).
2. Select one or two jacks to control.

**NOTE:** Only adjacent corners can be selected.

3. Press extend or retract.
4. Press the X to exit from MANUAL MODE.

Fig. 11



Fig. 12

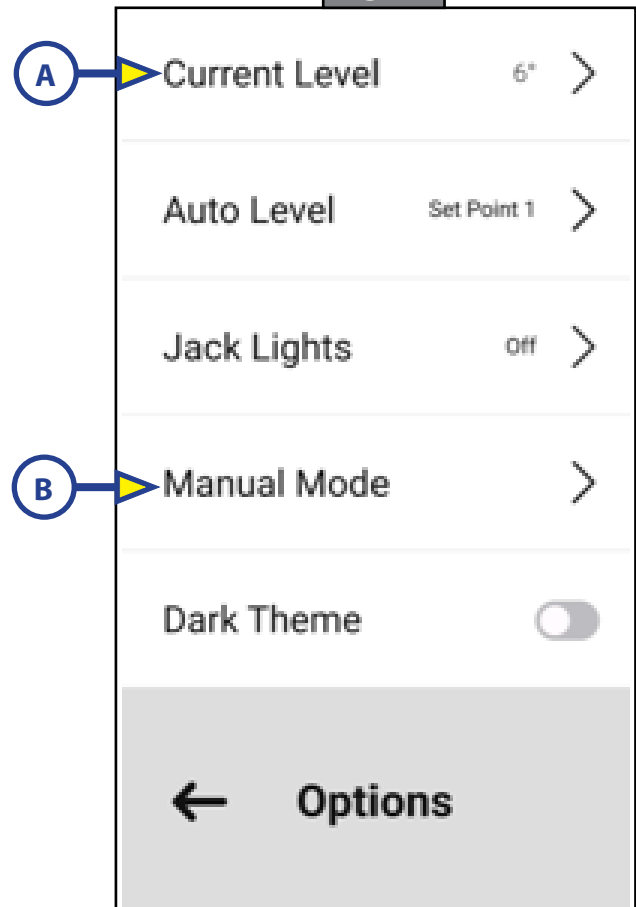

## Entering a Custom Set Point

Custom set points may be used to create a small tilt in the trailer to allow the rain to run off in a preferred direction, to create a large tilt to assist with draining tanks, or for other creative reasons that can be customized.

**NOTE:** The leveling controller will not allow an angle in excess of 5°.

To enter custom set points, enter SET POINT CALIBRATION MODE. This can be done in the OPTIONS menu (Fig. 13) by selecting AUTO LEVEL (Fig. 13A) and the set point to adjust, or from the CAMPING SCREEN (Fig. 14) by tapping the upper right corner of the SET POINT 1, 2, or 3 buttons.

**NOTE:** The factory set point can be adjusted as well. The large START AUTO LEVEL button on the CAMPING SCREEN (Fig. 14A) will automatically level the vehicle to the factory set point.

1. In SET POINT CALIBRATION MODE, adjust the position of the trailer.
2. Once the desired position is achieved, press SET to record the new set point position.

To achieve a level trailer, it is best to place a level in the center of the trailer in the front-to-back position and adjust the front and rear jacks in pairs until level first. Then, turn the level to the side-to-side position and adjust the position of the left and right jacks in pairs until level. Then confirm level in the front-to-back position again.

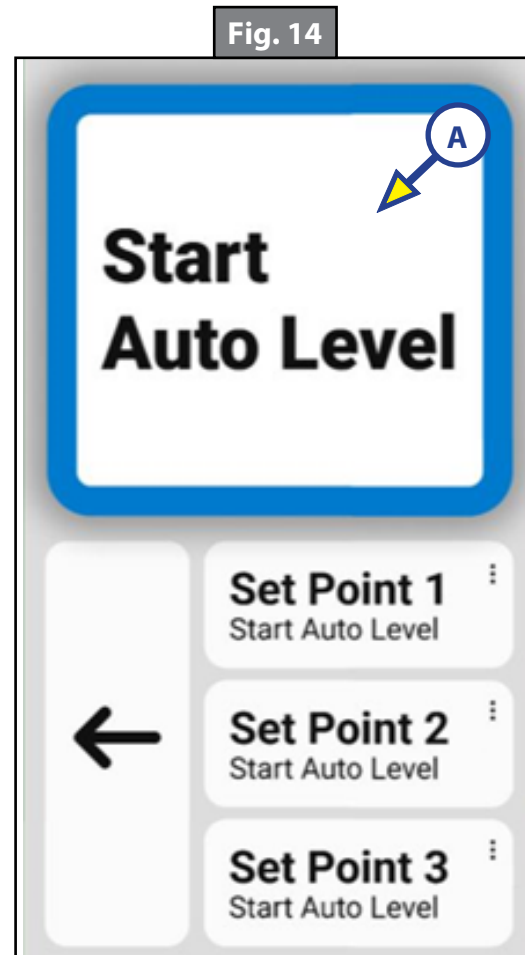
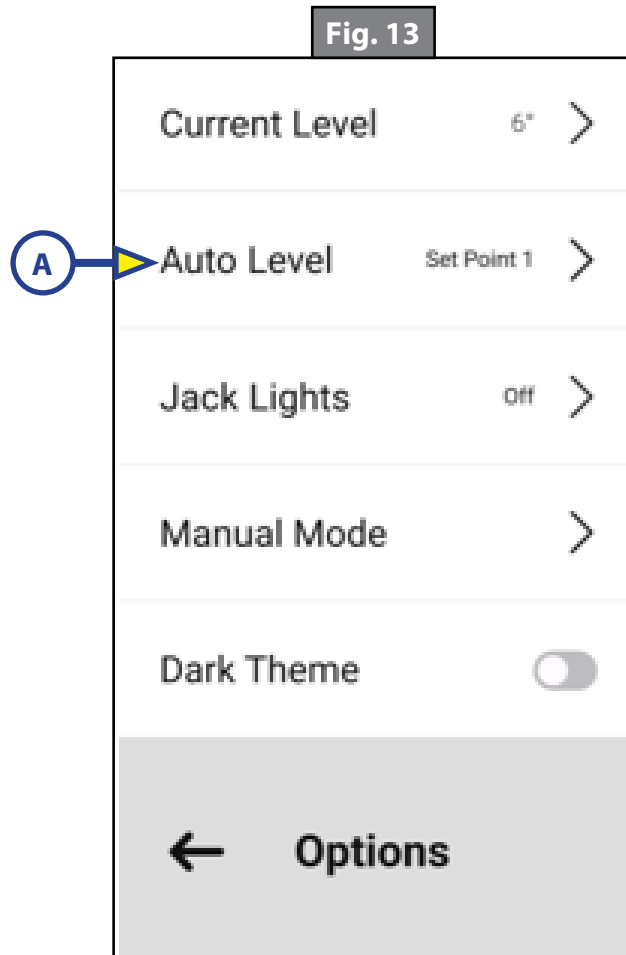

## Light Controls

Press the LIGHTS ON/OFF button on any screen to toggle the lights on and off. (Fig. 11B).

To adjust the brightness of the lights, or to adjust the auto-off timer, enter the OPTIONS (Fig. 15) menu and select JACK LIGHTS (Fig. 15A).

**NOTE:** If the lights were off, the lights will automatically turn on to the selected brightness (Fig. 16A) when adjusting the brightness. They will quickly turn off after the adjustment has been made, unless they are manually turned on.

The auto-off timer (Fig. 16B) will automatically turn your lights off after the selected period of time. The timer will restart after the lights have been turned on, whether manually, or automatically during auto-operations.

## Dark Theme

The touchscreen can be toggled between Light and Dark Theme by tapping the Dark Theme toggle button (Fig. 15B).

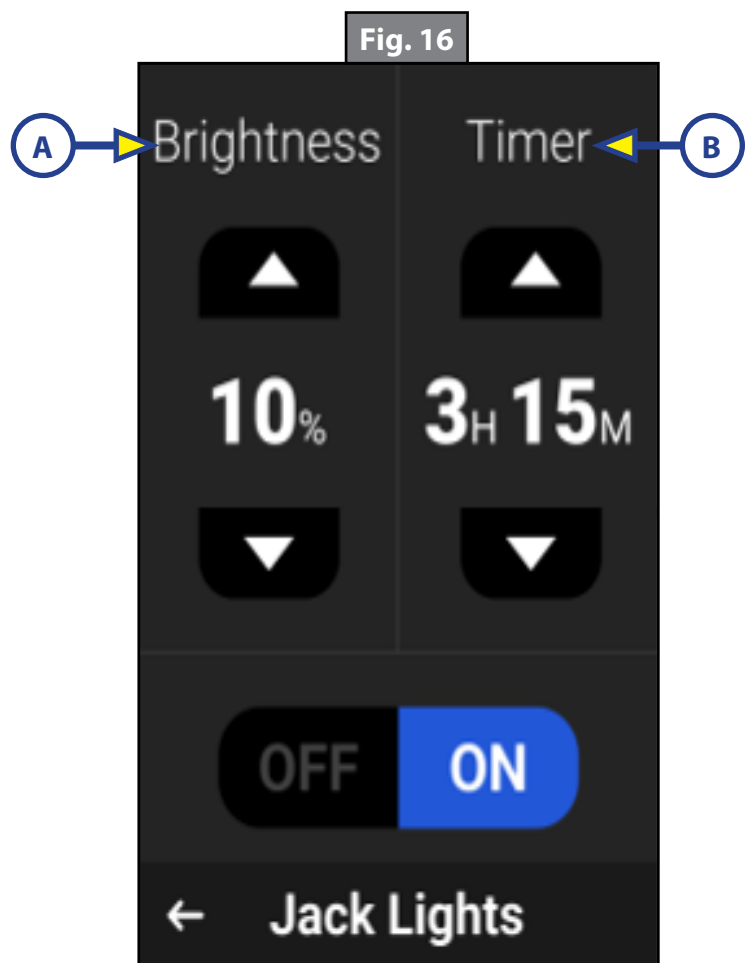
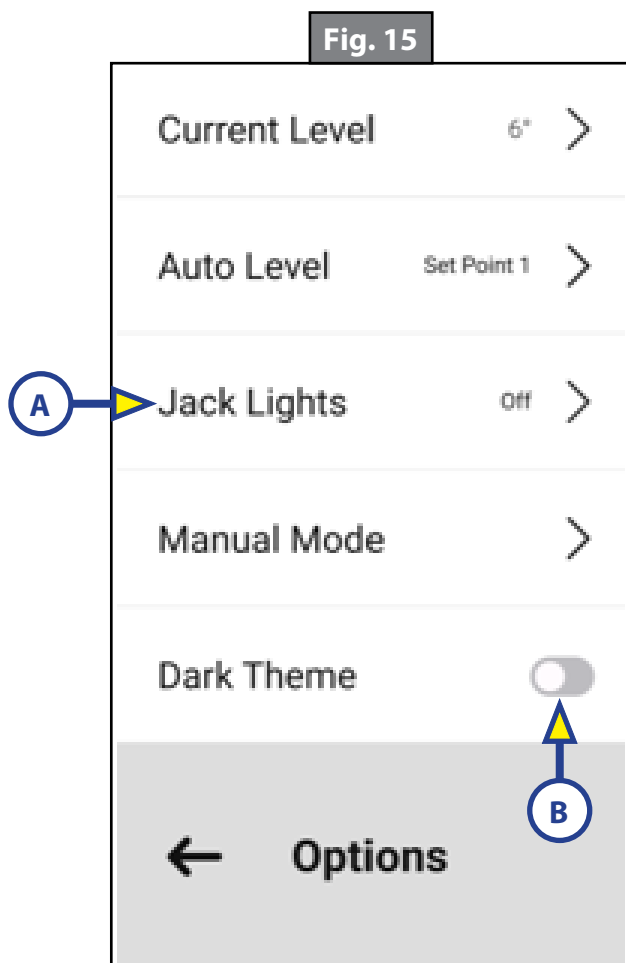

## Smart Device Pairing

Trailers equipped with Lippert OneControl will show leveling controls in the OneControl system. Pair a mobile smart device to the OneControl system and it will appear under the Leveling heading. For more information on OneControl visit: <https://support.lci1.com/onecontrol-wireless-formerly-myrv>.

If the trailer is equipped with only leveling, a mobile smart device may be directly paired to the leveler using the Lippert OneControl app.

Pairing a mobile smart device:

1. Locate the PAIRING CODE of the leveler.
  - A. The pairing code will likely be located on documentation supplied with your trailer. If not, it is located on the leveling controller (Fig. 17A). The leveling controller is typically located in the basement or pass-through.
2. Open the app and select the PLUS icon in the upper right.
3. Select SEARCH FOR DEVICES.
4. Select your Titan Leveling Systems leveling controller.
5. Enter the PAIRING CODE.
6. Leveling controls should now be visible in the OneControl Mobile App.

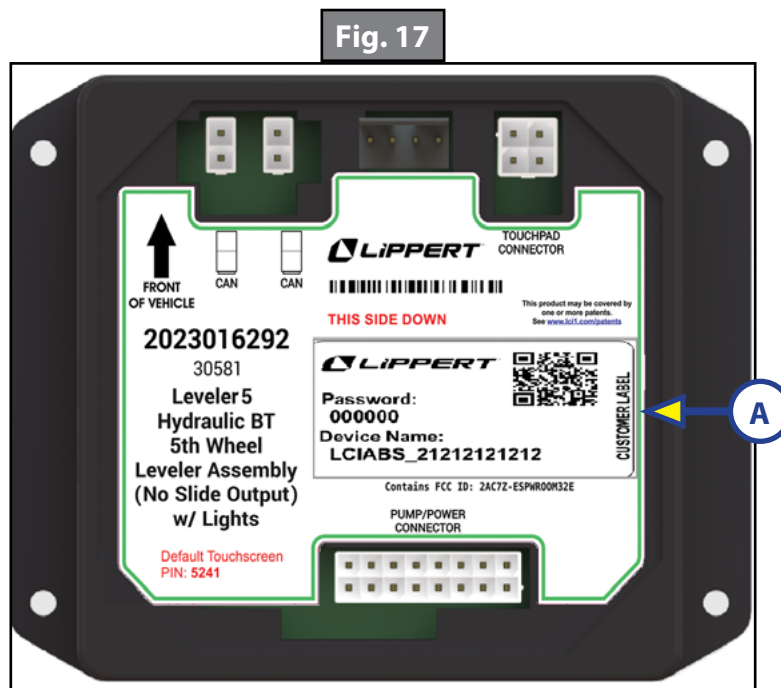

# Troubleshooting

## Error Messages

When the leveling controller detects an error, it will be presented to the user on the screen, along with some instructions for troubleshooting when appropriate. Most faults (Fig. 18) will clear automatically when the fault condition no longer exists.

1. To hide the message while troubleshooting, press HIDE MESSAGE (Fig. 18A).
2. An error message can be viewed at any time by pressing the caution icon in the OPTIONS SCREEN (Fig. 19A).
3. A caution icon will appear next to options button on the main screens until the fault is cleared (Fig. 20A).
4. To manually clear the fault, press CLEAR FAULT (Fig. 18B).

**NOTE:** Some faults will remain until the fault condition no longer exists.

Fig. 18

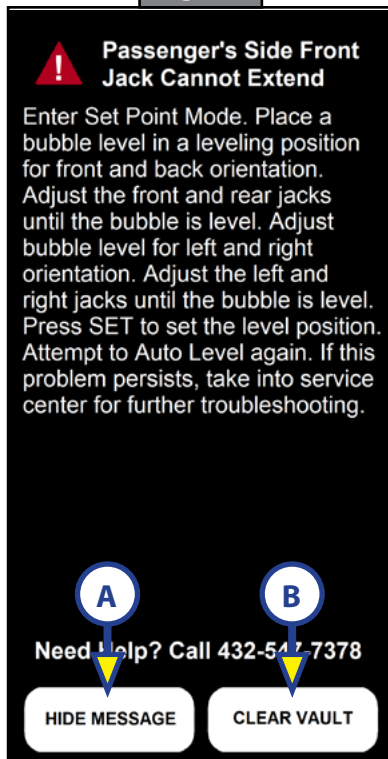
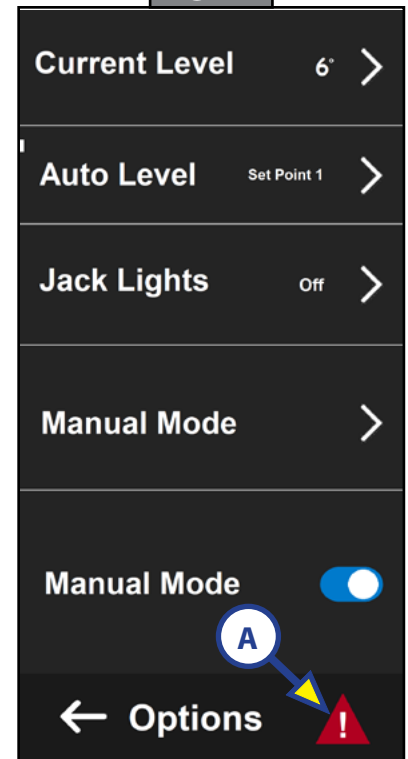

Fig. 19



Fig. 20



Error Message	What Should Be Done?
Controller Failure	Power cycle the leveler. If problem persists, return to a service center for replacement of the leveling controller.
Configuration Failure	Return to a service center for replacement of the leveling controller.
Low Battery Voltage Detected	Connect your battery to a charger, or connect your RV to shore power and ensure your converter is working. Give the battery time to charge before attempting again. Try again. If this problem persists, check the health of the battery.
No Auto Level Position Configured	To configure, enter Set Point mode. Place a bubble level on the RV floor in front and back orientation. Adjust the front and rear jacks until the bubble is level. Adjust bubble level for Right and right orientation. Adjust the Right and right jacks until the bubble is level. Press SET to set the level position. Attempt to Auto Level again.
Short Circuit Detected In Jack Light Output	Check the jack lights harnesses and connections on the jacks and on the controllers.
Driver's Side Rear Jack Cannot Extend Further	Return the RV to hitch-height. Position tow-vehicle to re-hitch. Lower RV onto hitch, and then, retract all jacks. Re-position RV in a location that appears more level and attempt to level your RV again.
Passenger's Side Rear Jack Cannot Extend Further	Return the RV to hitch-height. Position tow-vehicle to re-hitch. Lower RV onto hitch, and then, retract all jacks. Re-position RV in a location that appears more level and attempt to level your RV again.
Pump Power Breaker Tripped	Locate the inline fuse. Replace fuse with correct rating. If fuse cannot be located, contact the OEM for assistance in location of breaker.
Auto Level Failure	Return the RV to hitch-height. Position tow-vehicle to re-hitch. Lower RV onto hitch, and then, retract all jacks. Re-position RV in a location that appears more level and attempt to level your RV again.
Auto Retract Timeout	Check fluid level in hydraulic reservoir. Make sure batteries are fully charged. Check inline breaker between pump and batteries.
Auto Hitch Timeout	Check fluid level in hydraulic reservoir. Make sure batteries are fully charged. Check inline breaker between pump and batteries. Test again after next successful auto level. Adjust jacks manually to hitch RV if problem persists.
Ground Jacks Timeout	Return the RV to hitch-height. Position tow-vehicle to re-hitch. Lower RV onto hitch, and then, retract all jacks. Re-position RV in a location that appears more level and attempt to level your RV again. If error persists, take in for service.
Excess Angle Detected	The automatic operation was stopped due to the RV reaching the maximum allowed angle. If possible, adjust the jacks manually to achieve the desired result.
Action Temporarily Unavailable	Wait a moment and try the action again.

Error Message	What Should Be Done?
Touch Screen Power Failure	Remove the touchscreen bezel. Remove mounting screws. Check connector on touchscreen for damage. Check for broken, cut, crushed, or detached wires in wire harness. Reconnect cable and remount touchscreen and bezel. Locate leveling controller. Check connector on controller for damage. Reconnect cable and remount touchscreen and bezel. Attempt to use interface.
Hitch Point Not Set	Adjust the RV manually to connect to your vehicle. The hitch point is saved at the start of auto level.
Front Jacks Cannot Extend Further	Return the RV to hitch-height. Position tow-vehicle to re-hitch. Lower RV onto hitch, and then, retract all jacks. Re-position RV in a location that appears more level and attempt to level your RV again.
Action Prevented	The attempted action is not allowed due to a device lockout being active. Disconnect from your tow vehicle and try again.
Leveler Not Found	The leveling controller is not detected. Check the controller for disconnected cables.

## Set Point Calibration

The trailer is delivered with a pre-programmed factory set point. If needed, the set point can be changed by entering SET POINT CALIBRATION MODE as described in the Entering a Custom Set point section of this document and selecting the FACTORY SET POINT to adjust. This will be the level position the trailer will automatically adjust to when the large START AUTO LEVEL button on the CAMPING SCREEN is pressed. It is also the level position the trailer will reference in the OPTIONS menu CURRENT LEVEL display.

## Manual Override

The Lippert Titan Leveling System can be manually operated with an electric drill. In the event of electrical or system failure, this manual override method of extending and retracting the jacks can be used.

**NOTE:** Turn off the battery disconnect to shut off power to the hydraulic power unit motor prior to attempting the manual override procedure.

1. Locate the valves at the power unit (Fig. 21) that are paired with the landing gear or leveling jacks to be manually overridden.
2. Using a 5/32" hex wrench, open the valve by turning the manual override set screw clockwise (Fig. 22).
3. Remove protective label (Fig. 23) from power unit motor revealing manual override coupler (Fig. 24).
4. Using an electric drill with a 1/4" hex bit, insert the hex bit into the manual override coupler (Fig. 24) to manually operate the system.
  - A. Run the drill forward (clockwise) (Fig. 24) to retract the landing gear or leveling jacks.
  - B. Run the drill in reverse (counterclockwise) (Fig. 24) to extend the landing gear or leveling jacks.
5. Make sure to turn the manual override set screw on the valve back to the counterclockwise position after extending or retracting the landing gear or leveling jacks (Fig. 25).

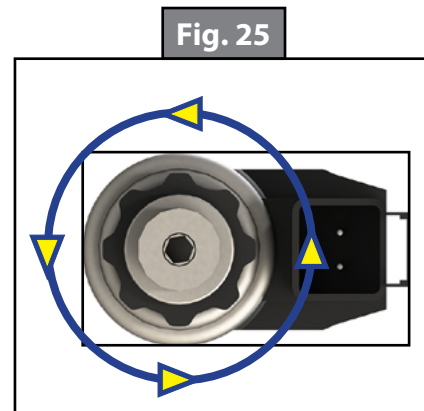
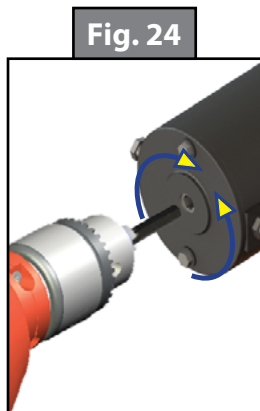
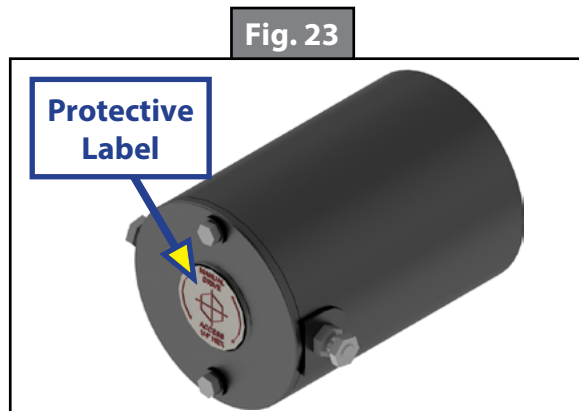
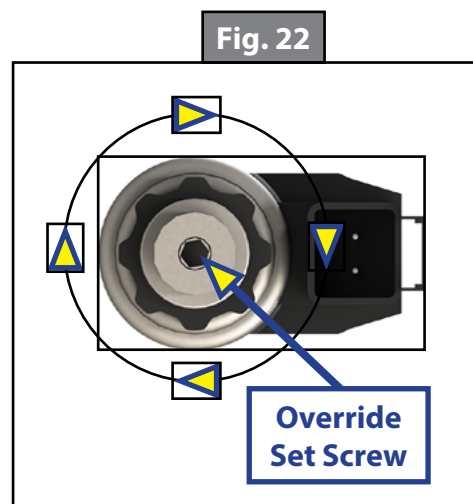
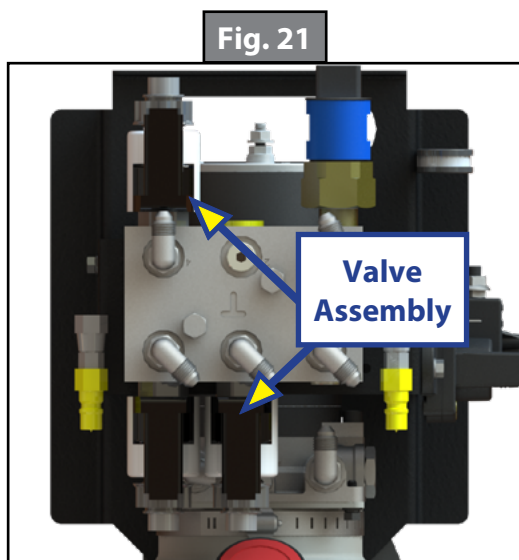

## Maintenance

1. Remove dirt and road debris from leveling jacks and landing gear as needed.
2. If jacks are down for extended periods, it is recommended to spray exposed jack tubes with a spray lubricant every three months for protection. If the 5th Wheel is located in a salty air environment, it is recommended to spray the jack tubes every 4 - 6 weeks.
3. Each month, check that the fluid level is within  $\frac{1}{4}$ " of the fill spout lip while leveling jacks and slide-outs are fully retracted.

**NOTE:** Always fill the reservoir with the leveling jacks and slide-outs fully retracted. Filling the reservoir when leveling jacks and slide-outs are extended will cause the reservoir to overflow into its compartment when the leveling jacks and slide-outs are retracted.

4. Inspect and clean all of the 5th Wheel's power and electrical connections prior to the first use of the 5th Wheel at the start of the traveling season and prior to storing the 5th Wheel. If corrosion is evident, clean all corrosion with a wire brush, then apply dielectric grease to the connections.
5. Make sure to turn the manual override set screw on the valve back to the counterclockwise position after extending or retracting the landing gear or leveling jacks.

## Fluid Recommendation

ATF with Dexron III® or Mercon 5® or a blend of both is recommended by Lippert.

Type "A" Automatic Transmission Fluid (ATF) is utilized and approved.

Hydraulic system operation in climates at or below 40 degrees F (4 degrees C) may result in the following:

- Slow operation during extension/retraction
- Incomplete retraction of jacks during Auto Retract procedure

**NOTE:** A visual inspection of the jacks in the retract position is recommended after completing Auto Retract.

For a list of approved fluid specifications, scan this QR Code or go to: [TI-188 - Hydraulic Operation Fluid Recommendation](#).



## Preventive Maintenance

1. Check hydraulic fluid in reservoir every 12 months. If fluid is a clear, red color, do not change. If fluid is milky, pink and murky, and not clear red in color, drain reservoir and add new fluid. Hydraulic fluid in reservoir should be changed a minimum of every five years.

**NOTE:** Check the fluid only when all the jacks are fully retracted.

**NOTE:** When checking the hydraulic fluid level, fill to within  $\frac{1}{4}$ " to  $\frac{1}{2}$ " of fill spout.

2. Inspect and clean all power unit electrical connections every 12 months. If corrosion is evident, use a small amount of lubricant to remove corrosion. Contacts must be cleaned with a non-residue cleaner

### **⚠ WARNING**

**The coach should be supported at both front and rear axles with jack stands before working underneath. Failure to do so may result in death, serious personal injury or severe product or property damage.**

prior to use. Lippert recommends the use of an electrical contact cleaner spray.

3. Remove dirt and road debris from jacks as needed.
4. If jacks are down for extended periods, it is recommended to spray exposed jack rods with a dry silicone lubricant every three months for protection. If the trailer is located in a salty environment, it is recommended to spray the rods every four to six weeks.

# Wiring Diagram

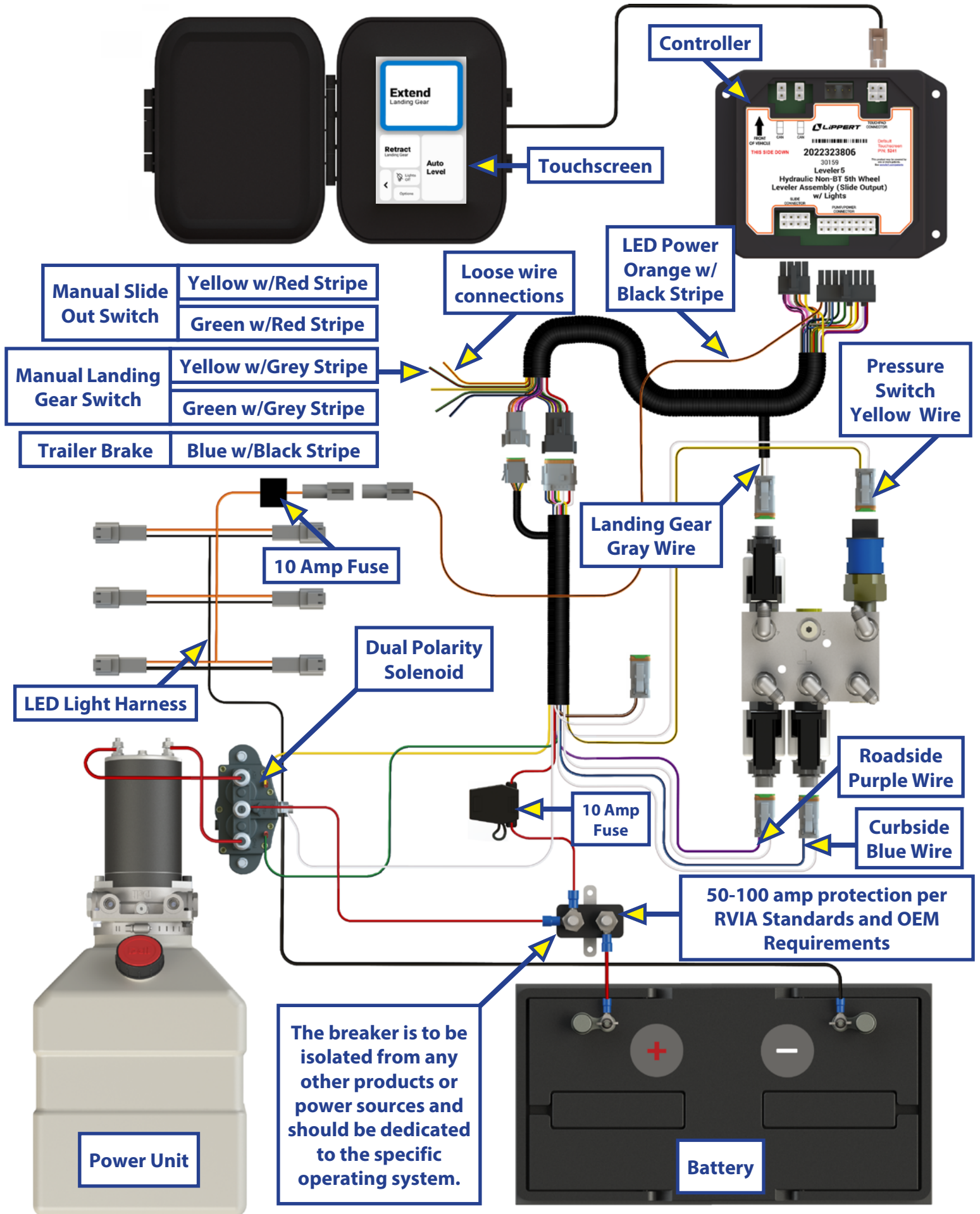

# Plumbing Diagram

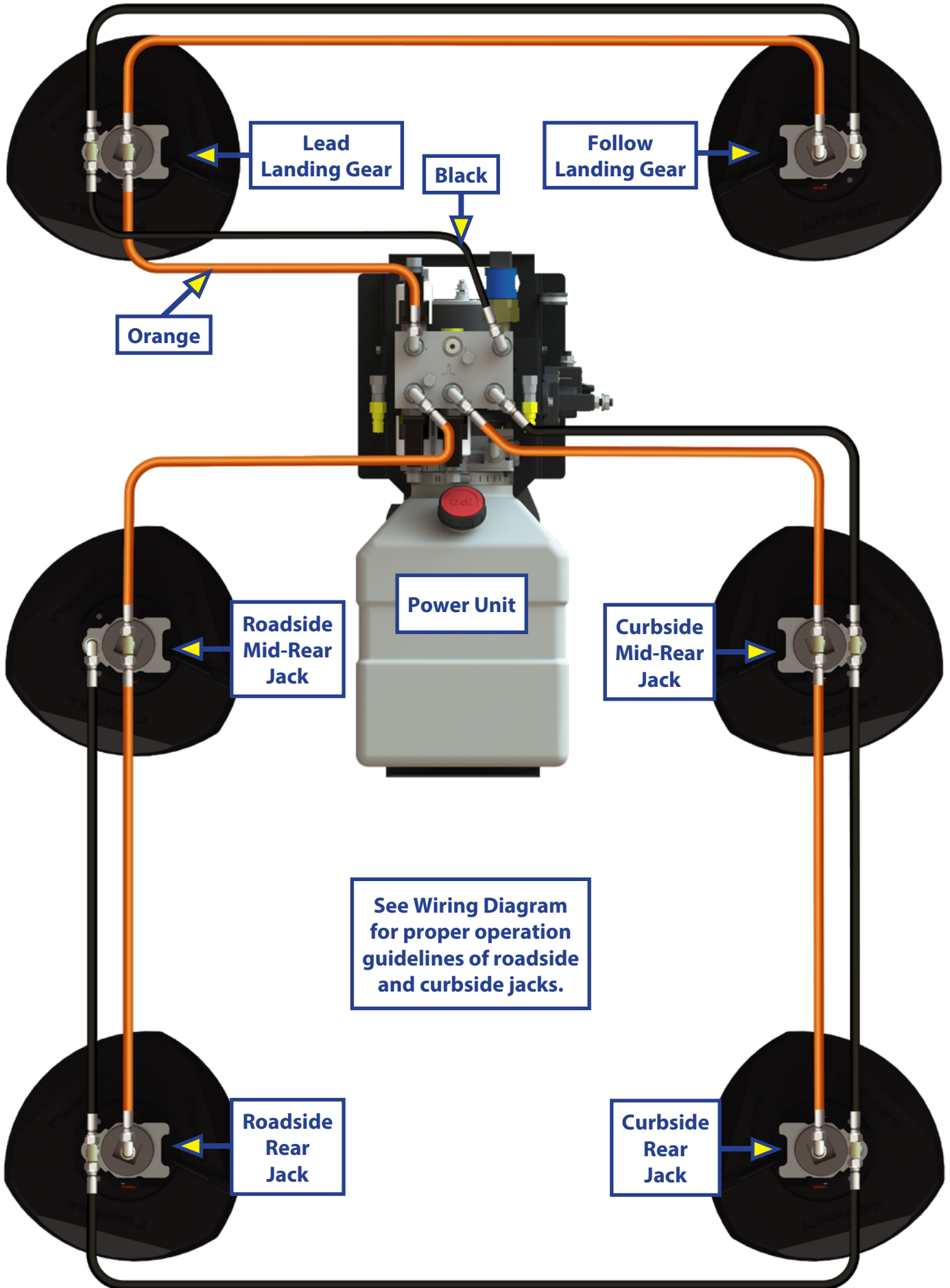



The contents of this manual are proprietary and copyright protected by Lippert. Lippert prohibits the copying or dissemination of portions of this manual unless prior written consent from an authorized Lippert representative has been provided. Any unauthorized use shall void any applicable warranty. The information contained in this manual is subject to change without notice and at the sole discretion of Lippert. Revised editions are available for free download from [lippert.com](http://lippert.com).

Please recycle all obsolete materials.

For all concerns or questions, please contact Lippert  
Ph: 432-LIPPERT (432-547-7378) | Web: [lippert.com](http://lippert.com) | Email: [customerservice@lci1.com](mailto:customerservice@lci1.com)