



LEVEL UP[®] LCD
5TH WHEEL LEVELING
OEM INSTALLATION MANUAL

TABLE OF CONTENTS

System Information	2
System Component Storage.....	2
Additional Information Sources	3
Component Description.....	3
Safety	4
Resources Required	4
Preparation	5
Installation	5
Mid and Rear Jacks.....	5
Front Landing Gear.....	7
Power Unit.....	8
Manifold Blocks (Dual and 4 Bank).....	8
Hydraulic Hoses.....	9
Leveling Sensor.....	10
Controller.....	11
Touchpad.....	12
Purging Hydraulic System	13
Operation	14
Prior to Operation.....	14
Touchpad Operation	14
Zero Point Calibration	15
Basic Jack Operation.....	15
Unhitching Instructions.....	16
Auto Level.....	16
Hitch Recognition.....	17
Troubleshooting	18
Error Codes.....	18
Troubleshooting Table	18
Wiring Diagram	19
Plumbing Diagram - Dual Manifold	20
Plumbing Diagram - 4 Bank Manifold	21

System Information

Please read and study the operating manual before operating the leveling system. The Lippert Level Up® 5th Wheel Leveling System is a hydraulic system. The system includes six points of contact utilizing aluminum jacks and multi-valve system. A 12V DC electric motor drives a hydraulic pump that moves fluid through a system of hoses, fittings and jacks to level and stabilize the trailer. The hydraulic pump should be isolated from any power source through a 50 - 100 amp protection per RVIA Standards and OEM Requirements. Mechanical portions of the Level Up® 5th Wheel Hydraulic Leveling System are replaceable. Contact Lippert to obtain replacement parts.

System Component Storage

Components **MUST** be stored inside, or undercover out of the weather to prevent moisture intrusion.

Additional Information Sources

Additional information about this product can be obtained from lci1.com/support or by downloading the free LippertNOW app. The app is available on Apple App Store® for iPhone® and iPad® and also on Google Play™ for Android™ users.

App Store®, iPhone®, and iPad® are registered trademarks of Apple Inc.

Google Play™ and Android™ are trademarks of Google Inc.

NOTE: Images used in this document are for reference only when assembling, installing and/or operating this product. Actual appearance of provided and/or purchased parts and assemblies may differ.

For additional support on this product, please visit:

<https://support.lci1.com/towable-br-level-up-support-towable-level-up-br-touch-pad>

Component Description

1. Jacks
 - A. Rated at a lifting capacity for the trailer.
 - B. Standard 9-inch diameter (63.5 square inch) foot pad on a ball swivel for maximum surface contact on all surfaces.
 - C. Optional 12-inch diameter - (113 square inch) foot pad also available.
 - D. Operational power from a 12V DC Motor/Pump assembly.
2. Motor/Pump Assembly
 - A. 12V DC motor
 - B. Hydraulic fluid reservoir tank
 - C. Control valve manifold
 - D. Solenoid valve
3. System Controls
 - A. Touch pad can be operated in manual mode or fully automatic mode.

Safety

WARNING

The “WARNING” symbol above is a sign that an installation procedure has a safety risk involved and may cause death or serious injury if not performed safely and within the parameters set forth in this manual. Always wear eye protection when performing this installation procedure. Other safety equipment to consider would be hearing protection, gloves, and possibly a full face shield, depending on the nature of the installation procedure.

WARNING

The trailer **MUST** be supported per manufacturer's recommendations before working underneath. Failure to do so may result in death or serious injury.

CAUTION

Moving parts can pinch, crush or cut. Keep clear and use caution.

The use of the Lippert Level Up LCD 5th Wheel Leveling System to support the trailer for any reason other than which it is intended is prohibited by the Lippert Limited Warranty. The Lippert Level Up LCD 5th Wheel Leveling System is designed as a leveling system only and should not be used for any reason to provide service under the trailer, e.g. changing tires or servicing the leveling system.

Lippert recommends that a trained professional be employed to change the tires on the trailer. Any attempts to change tires or perform other service while trailer is supported by the Level Up LCD 5th Wheel Leveling System could result in damage to the trailer and/or cause serious injury or death.

Resources Required

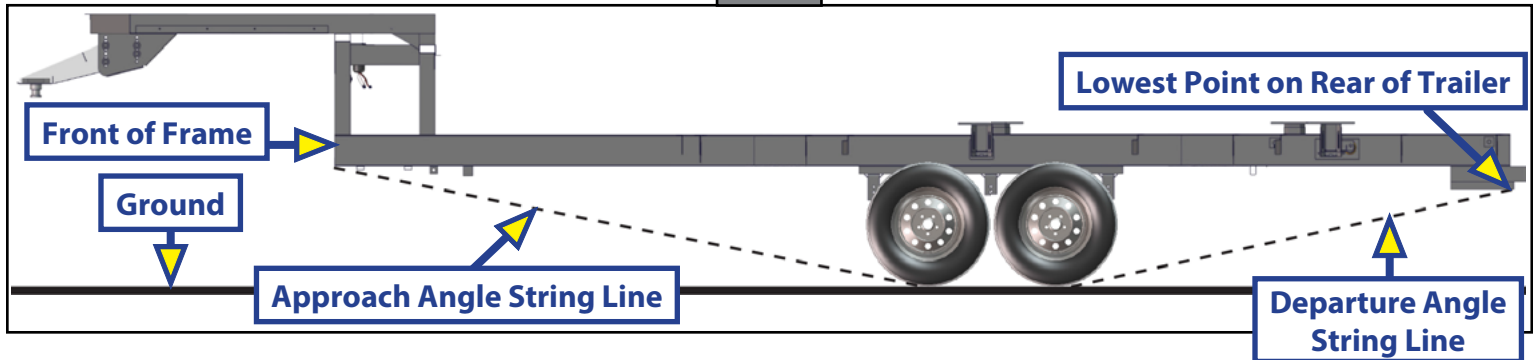
- Electric or cordless drill or screw gun
- Appropriate sockets
- Appropriate drive bits
- Torque wrench
- Open end wrenches
- Crimping tool
- Phillips head screwdriver
- Hand saw or reciprocating saw
- #12 x 1" hex head self-tapping screws
- #8 x 1" wood screws
- Measuring tape

Preparation

⚠ WARNING

The Level Up system for 5th wheels is only authorized for installation on Lippert brand frames with an I-beam of 8" or greater or a 6" x 2" x 10' gauge tube frame. Only Lippert frames with these parameters/dimensions have been tested and approved as compatible with the product.

Fig. 1



Installation

Mid and Rear Jacks

1. When fully retracted, the rear jacks MUST be mounted to achieve a minimum ground clearance equal to the departure angle (Fig.1) or no less than 8" and no more than 10" to the ground to enable maximum level correction. Any additional ground clearance added to the jack location will decrease the amount of level correction available to the system.
2. Bolt the leveling jacks (Fig. 2) to the mounting brackets (Fig. 3) to achieve proper ground clearance. Upper and lowermost bolts are vertically spaced a minimum 2-hole patterns (4.5 inches), and tightened to 80-90 ft-lbs (Fig. 4). A minimum spacing of 3-hole patterns (6.75") is recommended where possible.

NOTE: When installing the system, the rear jacks must be mounted within the departure angle, should be aligned with each other from side to side, mounted 12"-18" behind the rear tires on a tandem axle trailer or as close to the rear tire, as allowed, on a tri-axle trailer. The mid jacks should be mounted approximately 1 foot in front of the front tires. The mid jacks can be offset from each other side to side by up to 24" in order to fit the jacks around steps or other obstructions. The universal mounting brackets are designed to fit a 12" I-Beam with no modifications. However, the frame on the trailer may not be 12" or there may be obstructions where the jacks are to be mounted. If that is the case, measure for the modifications you need to make to the jack brackets.

3. Identify power unit mounting location. This will determine the orientation of the hydraulic fittings. If the power unit is, or will be, mounted on the driver's side of the front compartment, the driver's side front leveling jack will be the first jack in the system.
4. Install hydraulic fittings to leveling jacks. See figures 5 and 6 for details of fitting placement. This example assumes the hydraulic power unit is closest to the driver's side (roadside) of the trailer.
5. Measure and make the hydraulic hoses (orange for extend, black for retract).

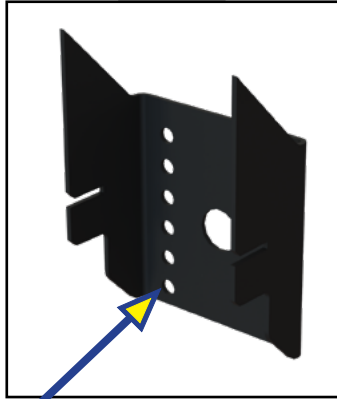
NOTE: Always follow the manufacturer's specifications for the correct minimum bend radius throughout the entirety of the hose route. Use gauges to verify areas with questionably tight bends. Fitting orientation can be adjusted in some applications. The correct bend radius is shown in Fig. 7.

- A. Measure the distance between the rear leveling jack to the mid jack.
 - I. Add three feet to this measurement to make sure that there will be enough hose material to run between jacks and prevent kinking.
 - II. This will be the measurement for the extend and retract hoses between mid and rear jacks.

Fig. 2



Fig. 3



Mounting Bracket

Fig. 4

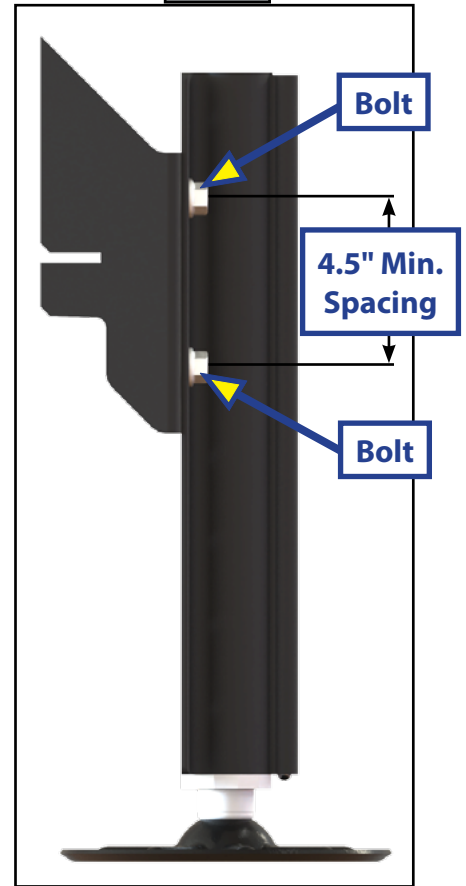


Fig. 5

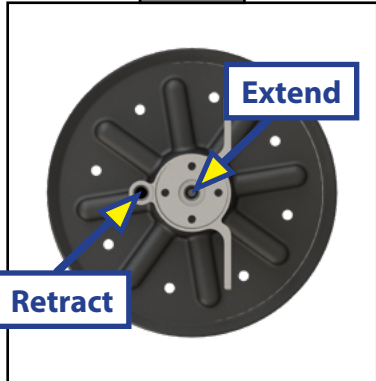


Fig. 6

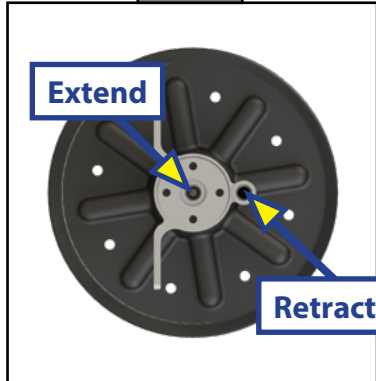


Fig. 7



B. Measure from the hydraulic power unit location to the landing gear on the side of the trailer closest to the hydraulic power unit location.

I. Add three feet to this measurement.

NOTE: Always follow the manufacturer's specifications for the correct minimum bend radius throughout the entirety of the hose route. Use gauges to verify areas with questionably tight bends. Fitting orientation can be adjusted in some applications. The correct bend radius is shown in Fig. 7.

II. This will be the length of the retract and extend hoses from the power unit to the landing gear on the side of the trailer closest to the hydraulic power unit.

NOTE: When installing system, measure and make the hydraulic hoses (orange for extend, black for retract). Measure from the rear leveling jack to the mid leveling jack. Add 3 feet to this measurement to ensure that there will be enough hose material to run between jacks and prevent kinking. This will be the measurement for the extend and retract hoses between the mid and rear jacks. For example, if the measurement is 9 ft., two 12 ft. orange hoses and two 12 ft. black hoses would be made. One 9 ft. black hose will need to be made to connect two rear jacks on the retract plumbing.

NOTE: All hoses must be run on top of the foil insulation inside the underbelly and through the chassis frame crossmembers. See the Plumbing Diagram for full details on the measuring, making, and installation of these hoses.

NOTE: Make sure hoses and wires are protected and properly fastened.

6. Secure all hoses to the proper fittings on each jack. Orange (extend) hoses connect to the fittings closest to the frame. Black (retract) hoses connect to the fittings farthest away from the frame. See also the Plumbing Diagram for a color-coded illustration of the hose orientation.

Front Landing Gear

1. Slide the jacks into position on the mounting brackets. On a straight frame, the jack should be positioned as low as possible while maintaining at least 12" of ground clearance when in the retracted position. On a drop frame, the jack should be placed as high as possible in order to maintain at least 12" of ground clearance. Use six bolts and nuts to attach the jack to the mounting bracket (Fig. 8). Upper and lowermost bolts should be placed in the top holes aligning with the top holes of the mounting bracket, and the sixth hole from the top, aligning with the bottom holes of the mounting bracket, and tightened to 80-90 ft-lbs.

NOTE: Make sure to not cross-thread the bolts and nuts.

2. Install the hydraulic fittings on the landing gears. See Plumbing Diagram for orientation.

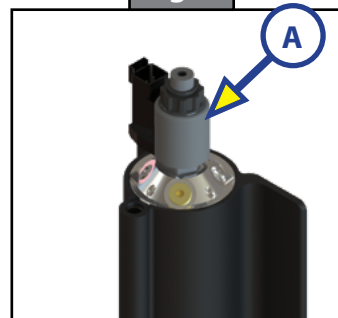
3. Install the spark-proof valve coil (Fig. 9A) assembly into the lead landing gear (Fig. 9).

NOTE: Spark-proof coil is required when lead landing gear is located in a compartment with an ignition hazard, such as a propane cylinder. A spade-valve coil may be used if an ignition hazard, such as a propane cylinder is not located in the compartment.

Fig. 8

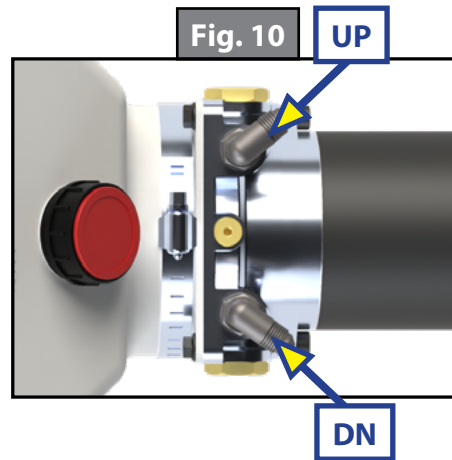


Fig. 9



Power Unit

1. The power unit mounting location was determined when the trailer was first inspected. Mount the power unit to the back or side wall of the front compartment in the position you previously determined using six (6) self tapping screws.
2. Install hose fittings into the power unit (Fig.10). The two ports are marked DN and UP. DN = Extend. UP = Retract.

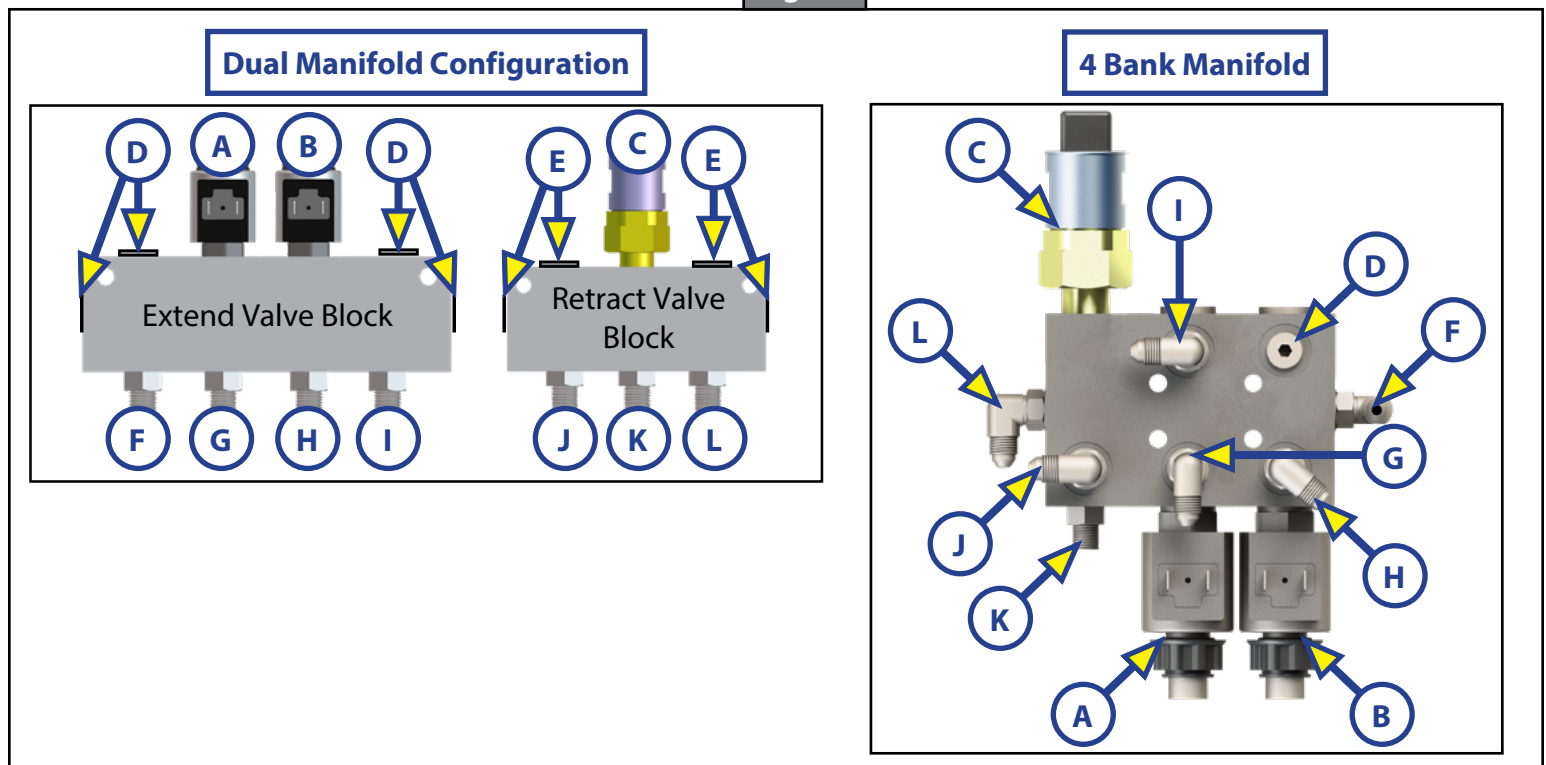


Manifold Blocks (Dual and 4 Bank)

1. Install two valve and coil assemblies in the manifold bank (Fig. 11A and 11B).
2. Install 4 fittings (Fig. 11F, 11G, 11H and 11I) into the manifold bank as shown. Install plugs (Fig. 11D) (removed from leveling jacks) into the open ports shown.
3. Install the Pressure Switch (Fig. 11C) in the manifold bank as shown. Install 3 fittings (Fig. 11J, 11K and 11L) into the ports shown. Install plugs (Fig. 11E) (removed from leveling jacks) into the ports shown.
4. Securely mount the valve blocks or 4 bank manifold close to the power source. Do not enlarge the mounting holes provided on the valve blocks.

NOTE: Do not over-tighten mounting screws. Over-tightening may deform or damage the valve blocks causing them to malfunction or leak.

Fig. 11



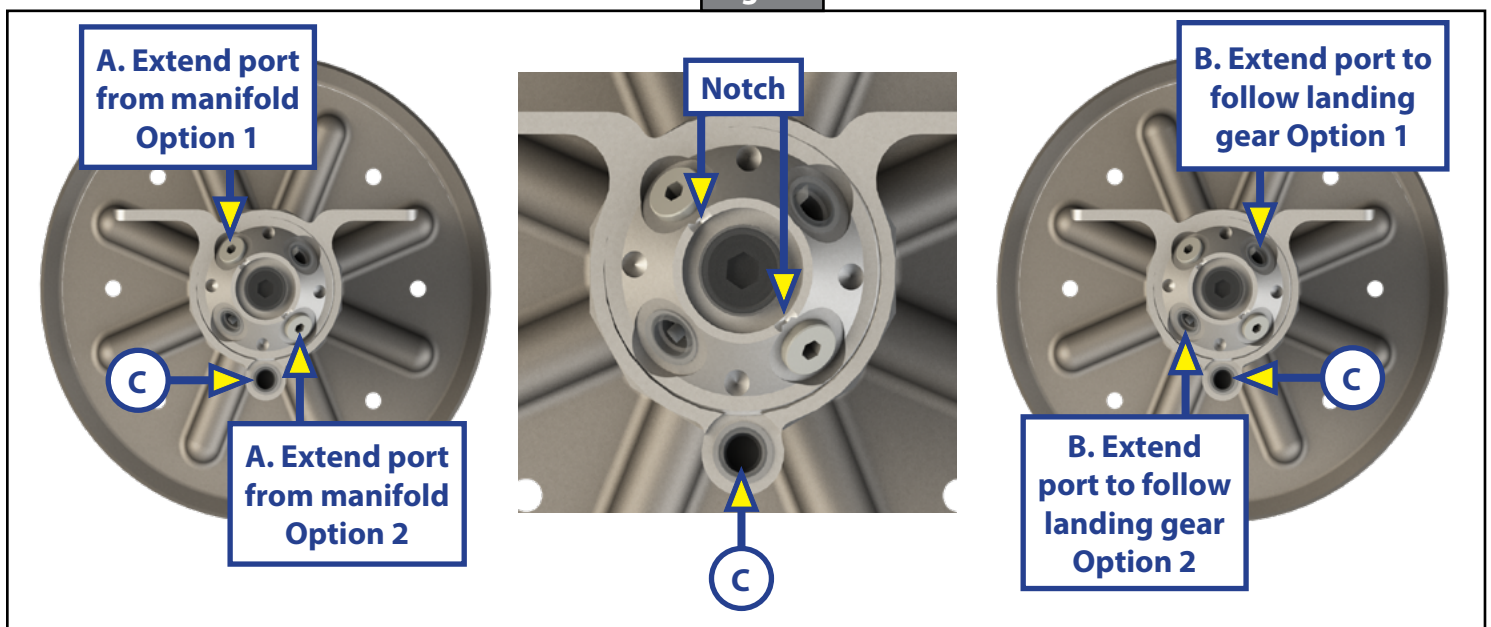
⚠ CAUTION

When installing hydraulic hoses, avoid areas of high heat, e.g. exhaust outlets. Do not use sharp or abrasive materials on or near hydraulic hoses.

Hydraulic Hoses

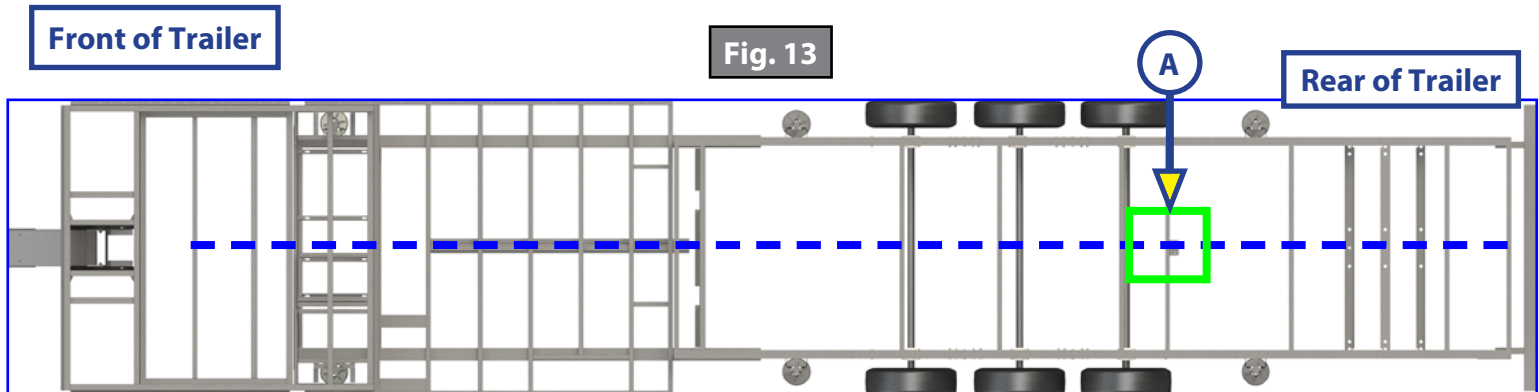
1. Connect the rear extend hoses (orange) to the fitting in the extend valve block and 4 bank manifold (Figs. 11G and 11H).
- NOTE:** The road side rear extend hose must be connected to a fitting that corresponds to a coil with the purple wire connected to it. The curb side rear extend hose must be connected to a fitting that corresponds to a coil with the blue wire connected to it.
2. Connect the mid and rear retract hose(s), a tee may be utilized or one continuous run. See Plumbing Diagram sections.
 3. Make hoses to connect the power unit to the valve blocks. 3' lengths should be sufficient; one (1) extend (orange) hose, and one (1) retract (black) hose.
 4. Connect the extend hose to the extend (DN) side of the power unit, and then to the fitting on the extend valve block or 4 bank manifold (Fig. 11F).
 5. Connect the retract hose to the retract (UP) side of the power unit, and then to the fitting on the retract valve block or 4 bank manifold (Fig. 11L).
 6. Make hoses to connect the valve blocks to the lead landing gear. Six-foot lengths should be sufficient; one (1) extend (orange) hose and one (1) retract (black) hose.
 7. Connect the extend hose to the final fitting on the extend valve block or 4 bank manifold (Fig. 11I) to either the option 1 or option 2 fitting in the extend port on the lead landing gear (Fig. 12A). These fittings are closest to the notch (Fig. 12) in the top of the jack.
 8. Connect the retract hose to the final fitting on the retract valve block (Fig. 11J) to a T-fitting in the retract port on the lead landing gear (Fig. 12C).
 9. Make hoses to connect the lead landing gear to the follow landing gear. Nine-foot lengths should be sufficient: one (1) extend (orange) hose, and one (1) retract (black) hose.
 10. Connect the retract hose to the T-fitting in the lead landing gear (Fig. 12C) and then to the fitting in the retract port of the follow landing gear.
 11. Connect the extend hose to either the option 1 or option 2 fitting in the extend port of the lead landing gear (Fig. 12B) and then to the fitting in the extend port of the follow landing gear.

Fig. 12

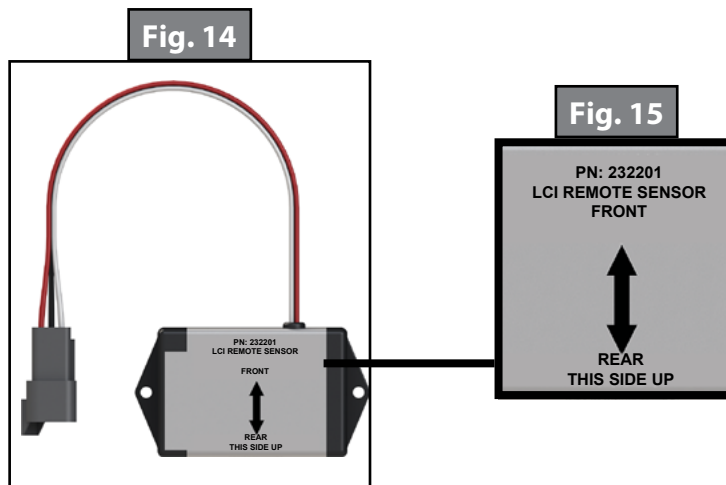


Leveling Sensor

The leveling sensor has a limited mounting area for proper performance. The rear sensor must be installed on the crossmember to the rear of the back axle, centered from curbside to roadside on the trailer with the arrows on the top of the sensor pointing the correct direction (Fig. 13A). The rear sensor must also be mounted in line with the center of the frame, as signified by the dotted blue line (Fig. 13).



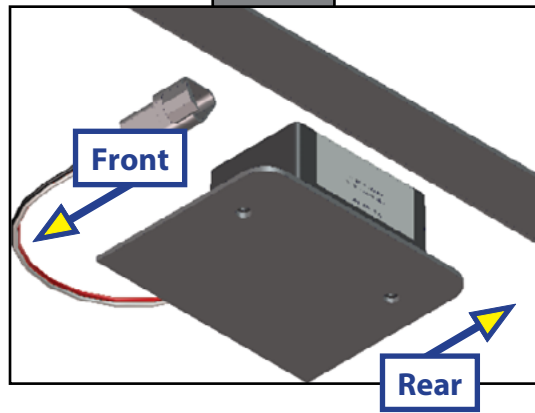
The leveling sensor (Fig. 14) must be oriented on the crossmember with the arrows on the top of the sensor pointing in the correct direction (Fig. 15). See figure 13A for location clarification.



Orientation is imperative for the correct operation of the leveling system (Fig. 16).

- A.** The pre-drilled holes in the plate are for mounting the rear sensor to the plate.
- B.** Properly orient the rear sensor and attach it to the mounting plate using two #12 x 1" hex head self-tapping screws (Fig.17).
- C.** Connect the rear sensor harness to the connector on the rear sensor and run the harness through the frame and up to the compartment where the controller will be mounted.

Fig. 16



Controller

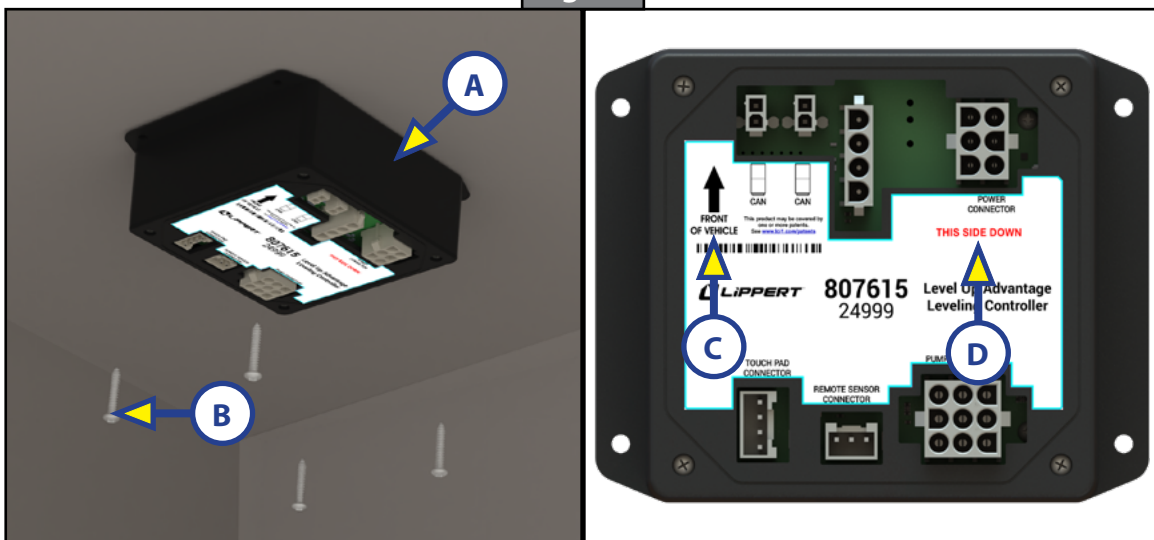
NOTE: The Level Up system wiring is basically a plug and play system. The kit should include harnesses for the entire system.

NOTE: Prior to starting this portion of the installation, double check that all of the harnesses are properly and securely connected to the leveling sensor.

NOTE: The compartment where the controller will be installed must be protected from the elements and the controller must be installed in compliance with RVIA Gas Codes, as the controller connections are not spark-proof.

1. Using four #8 x 1" wood screws (Fig. 17B), attach the controller (Fig. 17A) to the compartment ceiling.
 - A. Controller must be mounted with the label facing down (Fig. 17C) from a surface that is level with the horizontal plane of the chassis.
 - B. Controller must be mounted with the arrow facing the front of the trailer (Fig. 17D).
 - C. Connect all jack harnesses to the appropriate connectors on the controller. See Wiring Diagram.

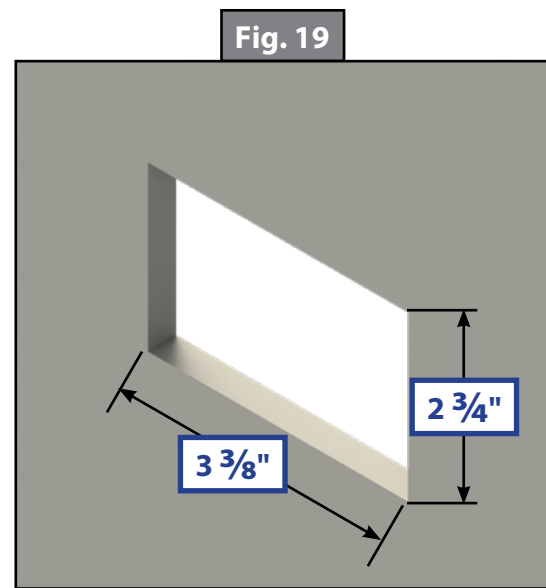
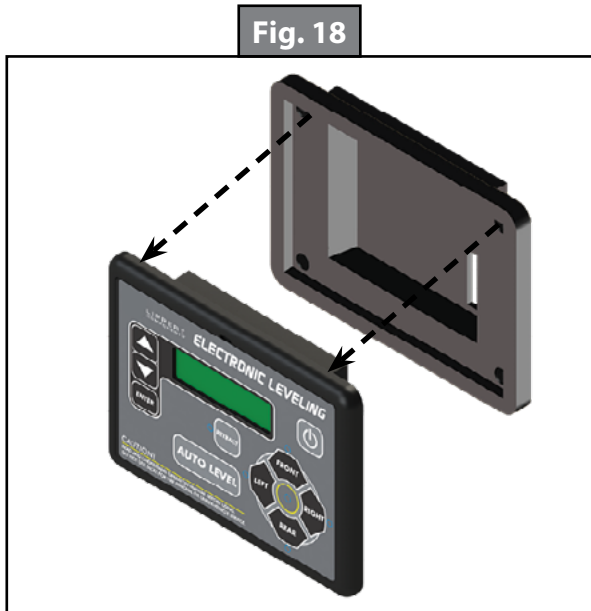
Fig. 17



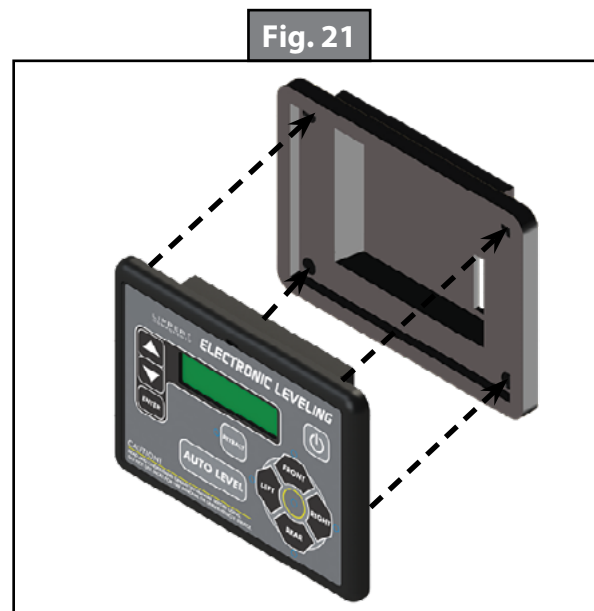
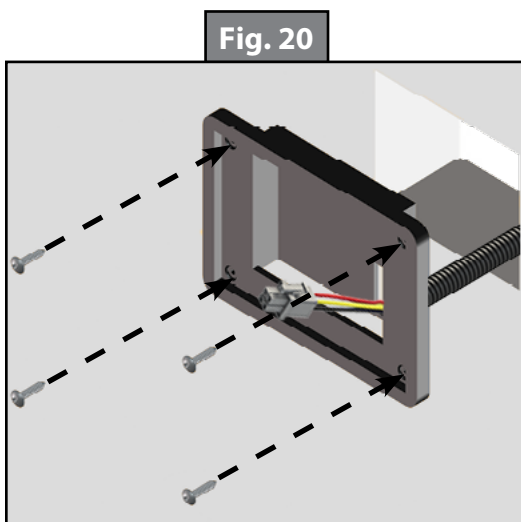
Touchpad

NOTE: The touch pad must be mounted in a weather tight environment. Operating instructions must be posted close to the touch pad for easy operator access

1. Determine where to mount the touchpad. The touchpad should be mounted in a compartment on the side of the trailer so the operator will have a view of the hitch pin while using the touchpad.
2. Remove the face plate of the touchpad from the mounting bezel (Fig. 18).
3. Cut a hole in the wall of the compartment 3 3/8" wide by 2 3/4" high so the top and bottom horizontal cuts are parallel to the floor of the compartment (Fig. 19).



4. Feed the touchpad harness through this hole and run it to the compartment where the controller is mounted (Fig. 20). Plug the harness into the appropriate connector on the controller.
5. Insert the touchpad bezel into the cutout and attach it with four #8 x 1" wood screws with sufficient length to thread into the compartment wall (Fig. 20).
6. Plug the touch pad harness into the connector on the back of the touch pad face plate and snap the face plate into the bezel (Fig. 21 and 22).



7. The last harness to connect is the one that powers and controls the system. One end will have two connectors that plug into the controller, a 9-pin and a 6-pin, and the other will have eight color coded wires.
8. Connect the 9-pin and 6-pin connectors to the proper ports on the controller.
9. Connect a ground wire from each of the valve coils to the ground post on the chassis.
10. Connect a ground wire from the ground post on the dual polarity solenoid, to a grounding bolt on the frame of the trailer. This will ground the entire system.

NOTE: These grounding wires are OEM installed.

11. Connect a power wire to the center post of the dual polarity solenoid. Mount a 50-100 amp circuit protection per RVIA standards to the back wall of the front compartment. Connect the power wire from the dual polarity solenoid to the AUX end of the 50-100 amp circuit protection. Connect another power wire to the BAT- side of the 50-100 amp circuit protection and run that to the battery or buss-breaker battery hookup. The fuse must be located within 18" of the circuit protection.

NOTE: Shore power (plugged in) does not operate the Level Up system as shore power is alternating current (AC). The unit must be connected to a 12V DC battery, the correct source of direct current (DC) for the hydraulic power unit.

Purging Hydraulic System

WARNING

Do not attempt to purge this system without the front end of the 5th Wheel safely supported. Doing so could result in death or serious bodily injury.

NOTE: Refer to [TI-118](#), Basic Purge Procedure for Hydraulic Pumps.

NOTE: Use a purging machine to clear hydraulic fluid of air and foam.

1. Start with all hydraulic components in the fully retracted position, meaning all jacks, landing gear, stabilizers and slide-outs brought back inside the trailer as if it were ready to travel.
2. Find the hydraulic pump location and note the amount of fluid currently in the reservoir. The fluid level should be about ¼" from the top of the reservoir and no more than ½" from the top.

NOTE: All valves must be energized via Lippert supplied text box.

3. Connect Lippert supplied purge machine to the quick disconnect fittings on the pump.
4. Fully extend and retract all hydraulic components 3 times.
5. Extend Hydraulic Landing Gear until footpads contact the ground, extend rear jacks to touch the ground, extend all Slide-Outs. Retract all Slide-Outs immediately, retract rear jacks and then retract Hydraulic Landing Gear.

NOTE: Purging of the system should take place in the chassis prep area prior to setting decking to observe any leaks or improper function of the system.

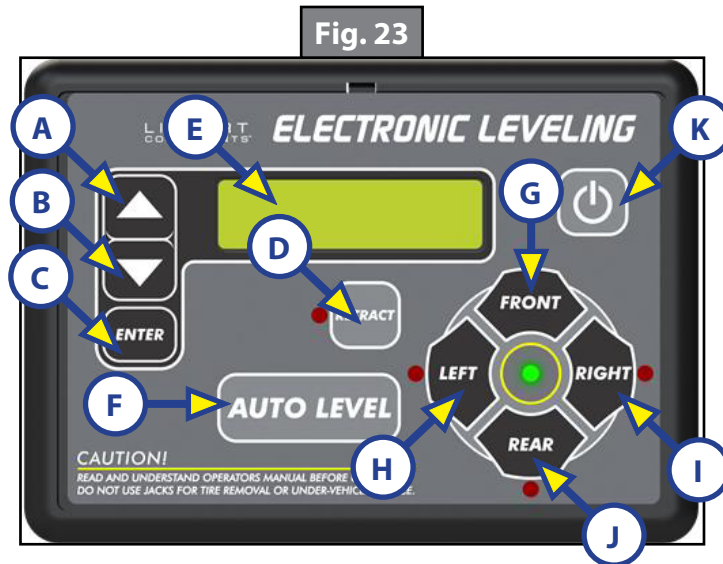
Operation

Prior to Operation

The leveling system shall only be operated under the following conditions:

1. The trailer is parked on a reasonably level surface.
2. Make sure all persons and property are clear of the trailer while the Level Up LCD 5th Wheel Leveling system is in operation.
3. Make sure the battery of the trailer is fully charged prior to attempting to operate the system. The automatic leveling system requires a minimum of 12V DC from the battery for operation.

Touchpad Operation



Column A	Column C
A	Up Arrow - Scrolls up through the menu on LCD.
B	Down Arrow - Scrolls down through the menu on LCD.
C	ENTER - Activates modes and procedures indicated on LCD.
D	RETRACT - Places leveling system into retract mode.
E	LCD Display - Displays procedures and results.
F	AUTO LEVEL - Places leveling system into auto level mode.
G	FRONT Button - Activates both front jacks.
H	LEFT Button - Activates left leveling jack(s) in manual mode.
I	RIGHT Button - Activates right leveling jack(s) in manual mode.
J	REAR Button - Activates leveling jacks in manual mode.
K	Power Button - Turns leveling system on and off.

Zero Point Calibration

The Zero Point is the programmed point that the trailer will return to each time the Auto Level feature is used. The Zero Point must be programmed prior to using the Auto Level feature to ensure the proper operation of the system.

NOTE: Prior to starting this procedure, double check all connections on the controller, valve coils, jacks and touchpad.

NOTE: Prior to calibrating Zero Point make sure the unit is connected to a fully charged battery pack, not just shore power. Failure to do this may cause memory loss of settings.

1. Manually run the jacks to level the trailer. This is best achieved by placing a level in the center of the trailer and leveling it both front-to-back and then side-to-side.
2. Once the trailer is level, turn off the touchpad.
3. With the touchpad off, press and release the FRONT button (Fig. 23G) 10 times and then press and release the REAR button (Fig. 23J) 10 times.
4. The touchpad will flash and beep and the display will read ZERO POINT CALIBRATION; ENTER to set, Power to Exit" (Fig. 24).
5. To set the current position as the zero point, press the ENTER button.
6. LCD display will read "Zero point stability check" (Fig. 25).
7. LCD display will read "Zero point set successfully" once process is complete (Fig. 26).
8. The system will set this point as its level state and the touch pad will turn off. To unhitch from the tow vehicle, make sure trailer is parked on a level surface and tires are chocked.

Fig. 24

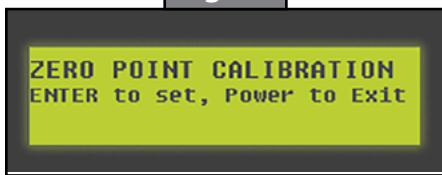


Fig. 25

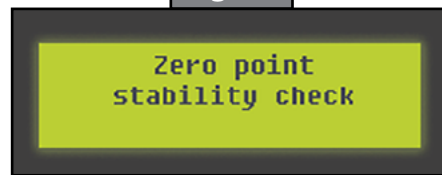
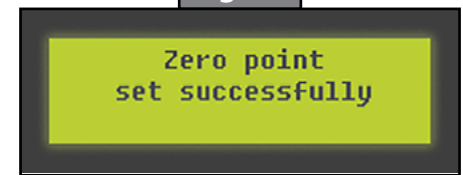


Fig. 26



Basic Jack Operation

1. Landing Gear Jacks
 - A. Landing gear jacks can be operated any time the system is on, but not in AUTO MODE. Press the FRONT button (Fig. 27F), so that both the front or landing gear jacks can be extended.
 - B. If the touch pad is put in the RETRACT mode, indicated by the orange illuminated LED next to the RETRACT button (Fig. 27I), the front jacks can be retracted together by pressing the FRONT button.
2. Level Up Jacks
 - C. The Level Up jacks operate when "AUTO MODE" is activated or the touch pad is in "MANUAL MODE". Once the system is in "MANUAL MODE", press the REAR button (Fig. 27H) to extend all Level Up jacks at the same time.

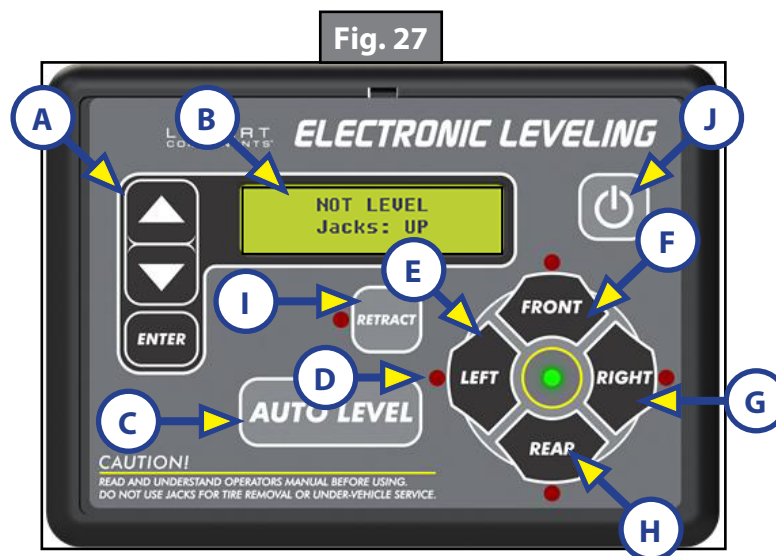
NOTE: Manual and Auto modes can be selected through the LCD menu by using the Up and Down Arrow buttons, then press ENTER to select the desired mode

- A. Press the LEFT or RIGHT buttons (Fig. 27 or 27G) to operate Level Up jacks on the left (road) or right (curb) side of the trailer, respectively.

Unhitching Instructions

1. Press Power button , (Fig. 27J) to turn system on. The LCD screen (Fig. 27B) lights up.
2. The LCD will display "NOT LEVEL; Jacks: UP" (Fig. 27B).
3. Orange arrow lights (Fig. 27D) may come on, indicating the current disposition of the trailer.
4. Press FRONT button (Fig. 27F) to extend landing gear jacks to lift front of the trailer to take the weight of the 5th Wheel off the hitch.
5. Uncouple the 5th Wheel connection on the tow vehicle.
6. Pull the tow vehicle away and park it at a safe distance.

Auto Level



NOTE: Prior to unhitching from the tow vehicle, make sure trailer is parked on a level surface and the tires are chocked.

1. After unhitching from tow vehicle, press AUTO LEVEL (Fig. 27C).

NOTE: Pressing any button during an Auto Level sequence will abort the auto leveling cycle.

NOTE: In order for the hitch recognition feature to function, the auto level sequence MUST be started with the front of the trailer above level.

2. Front landing gear will retract, lowering the front of the unit below level, stopping, then lifting the front end to level the unit front-to-back.
3. The left side leveling jack extends and raises the roadside of the unit.
4. The right side leveling jack extends and raises the curbside of the unit, beginning side-to-side leveling.
5. The front landing gear extend to complete the leveling cycle.
6. Additional left-to-right or front-to-back leveling may occur, if the controller deems necessary.

NOTE: If the auto level sequence does not happen as stated above, check to ensure proper manual function in all zones.

Hitch Recognition

1. Turn on touchpad.
2. Press the LEFT and RIGHT buttons simultaneously (Fig. 27E and 27G).
3. The front of the trailer will raise to the height where the auto level sequence was started.

NOTE: If the auto level sequence was started with the front of the trailer in a below-level condition, the hitch recognition will not function and the LCD will display "Feature Disabled." For hitch recognition to function, the auto level sequence must be started with the front of the trailer above level.

4. Connect tow vehicle and make sure 5th Wheel and hitch are connected and locked.
5. Press Up arrow (Fig. 27A) arrow until "AUTO RETRACT" appears in LCD screen.
6. Press ENTER. System will immediately retract all jacks.

Troubleshooting

Error Codes

To clear an error from the touch pad, repair or otherwise correct the issue, press ENTER. If the error is still present, the message will be displayed again.



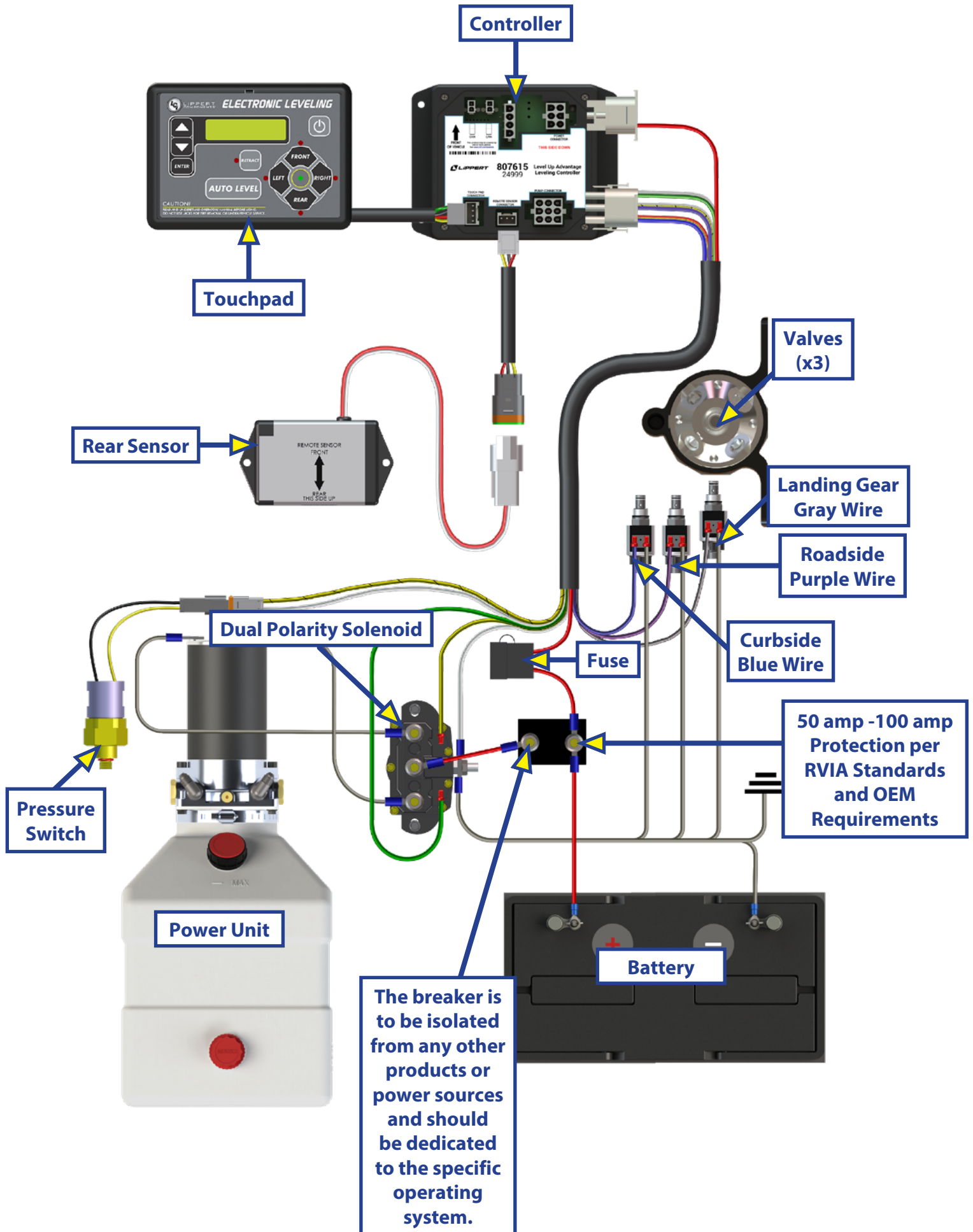
Make sure the trailer is supported at both the front and rear with jack stands before performing any troubleshooting or service to the trailer. Failure to do so may result in death or personal injury.

NOTE: Do not lift the trailer by the axles. The axles were not designed as a viable lift-point

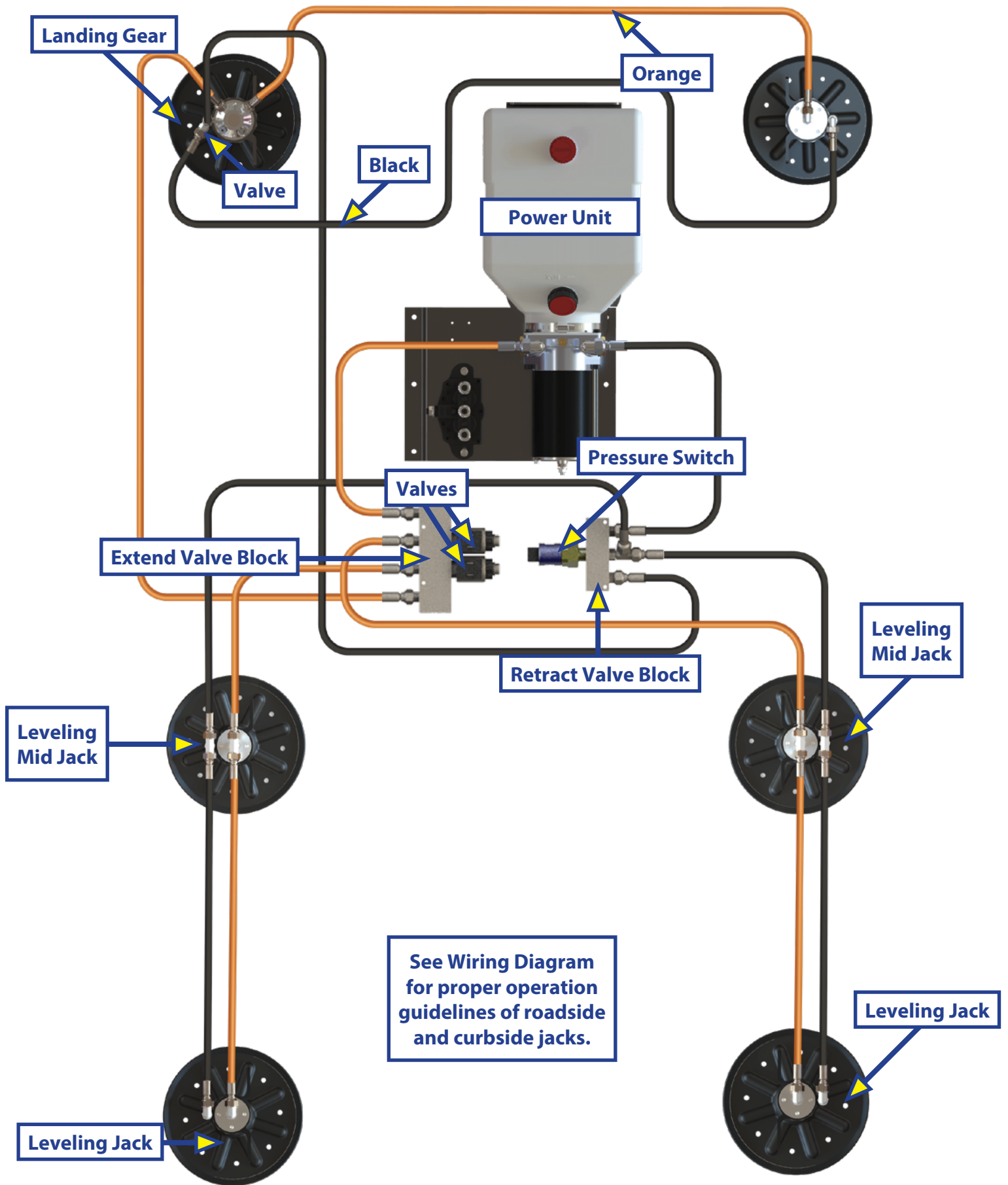
Troubleshooting Table

Error Codes		
LCD Screen Message	What Is Happening?	What Should Be Done?
"Excess Angle"	Controller not properly secured.	Check and secure controller placement.
	Excessive angle reached during auto operation.	Relocate the trailer.
"Excessive Angle"	Controller not properly secured.	Check and secure controller placement.
	Excessive angle reached during manual operation.	Relocate the trailer.
"Feature Disabled"	Front of trailer below level when starting auto level process but only when initiating Hitch Recognition.	Push the FRONT button to raise the trailer up to hitch height and connect to tow vehicle.
	Touch pad power not cycled between consecutive leveling operations.	Turn touchpad off and then back on to reset the system.
	Zero Point not set.	Set Zero Point.
"Low Voltage"	Battery dropped below 9.5V.	Check wiring - repair or replace.
		Test battery voltage under load - charge or replace.
"Out of Stroke"	Jack has reached maximum stroke length and is unable to lift.	Check disposition of jacks or relocate trailer.
"External Sensor"	Bad connection or wiring from the controller to the rear sensor.	Replace or repair connection to rear remote sensor.
"Jack Time Out"	Time limit exceeded for the requested auto operation.	Check disposition of jacks.
"Auto Level Fail"	Unable to auto level due to uneven ground.	Check disposition of jacks and/or relocate the trailer.
	Unable to auto level due to Zero Point being set incorrectly.	Reset Zero Point.
"Bad Calibration"	Sensor calibration values are out of range.	Replace controller.
"Internal Sensor"	Internal sensor problem.	Replace controller.
PANIC STOP "Function Aborted"	The user pressed a button on the touchpad during an automatic operation.	Restart automatic operation and then refrain from pressing any buttons on the touchpad.

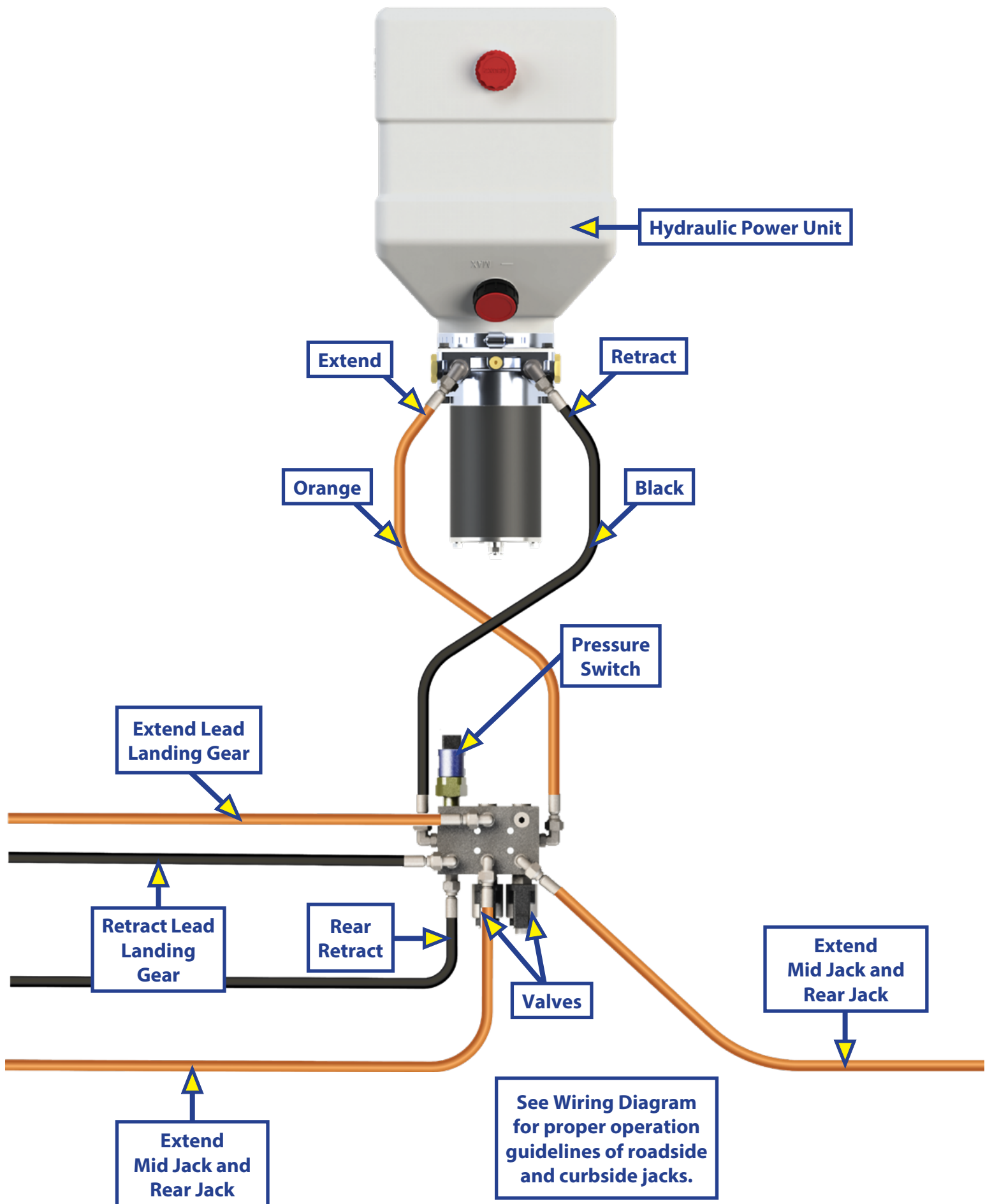
Wiring Diagram



Plumbing Diagram - Dual Manifold



Plumbing Diagram - 4 Bank Manifold





The contents of this manual are proprietary and copyright protected by Lippert. Lippert prohibits the copying or dissemination of portions of this manual unless prior written consent from an authorized Lippert representative has been provided. Any unauthorized use shall void any applicable warranty. The information contained in this manual is subject to change without notice and at the sole discretion of Lippert. Revised editions are available for free download from lippert.com.

Please recycle all obsolete materials.

For all concerns or questions, please contact Lippert
Ph: 432-LIPPERT (432-547-7378) | Web: lippert.com | Email: customerservice@lci1.com