



## Lewmar® Axis™ (Shallow Water Anchor) Installation and Owner's Manual (For Aftermarket Applications)

### Lewmar Axis Shallow Water Anchor Kits

Part #	Description
<a href="#">2022108804</a>	Lewmar Axis Shallow Water Anchor - White
<a href="#">2022108805</a>	Lewmar Axis Shallow Water Anchor - Black

### Additional Lewmar Axis Shallow Water Anchor Mounting Bracket Kits—Sold Separately

Part #	Description
2023043513	Quick Release Mounting Bracket
N/A	Jack Plate Mounting Bracket
N/A	Engine Mounting Bracket
N/A	Pontoon Deck Mounting Bracket

## Table of Contents

<b>Introduction</b> .....	2
<b>Safety</b> .....	2
<b>Parts List</b> .....	3
<b>Resources Required</b> .....	3
<b>Installation</b> .....	3
Determine Transom Mounting Location .....	3
Mounting the Anchor .....	3
Additional Anchor Mounting Brackets .....	4
Mounting the RF Module .....	5
Programming the RF Module .....	5
<b>Operation</b> .....	6
<b>Troubleshooting</b> .....	7
<b>Maintenance</b> .....	8
Manual Override .....	9
<b>Warranty Coverage - Components</b> .....	10
<b>RF Module Mounting Template</b> .....	11

## Lewmar® Axis™ (Shallow Water Anchor)

Installation and Owner's Manual  
(For Aftermarket Applications)

### Introduction

Thank you for choosing Lewmar®. Lewmar products are world renowned for their quality, technical innovation and proven performance. With a Lewmar product you will be provided with many years of outstanding service.

Operating your new Lewmar Axis™ Shallow Water Anchor is as simple as pushing a button on the remote control or the switch on the RF module.

Additional information about this product can be obtained from [lci1.com/support](http://lci1.com/support) or by using the LippertNOW app. Replacement kits can be ordered from <https://store.lci1.com/> or by using the LippertNOW app.

The LippertNOW app is available for free on Apple App Store® for iPhone® and iPad® and also on Google Play™ for Android™ users.

App Store® and iPad® are registered trademarks of Apple Inc.

Google Play™ and Android™ are trademarks of Google Inc.

### Safety

Read and fully understand all instructions before installing or operating this product. Adhere to all safety labels.

This manual provides general instructions. Many variables can change the circumstances of the instructions, i.e., the degree of difficulty, operation and ability of the individual performing the instructions. This manual cannot begin to plot out instructions for every possibility, but provides the general instructions, as necessary, for effectively interfacing with the device, product or system. Failure to correctly follow the provided instructions may result in death, serious personal injury, severe product and/or property damage, including voiding of the Lippert limited warranty.

#### **WARNING**

THE "WARNING" SYMBOL ABOVE IS A SIGN THAT AN INSTALLATION PROCEDURE HAS A SAFETY RISK INVOLVED AND MAY CAUSE DEATH, SERIOUS PERSONAL INJURY, SEVERE PRODUCT AND/OR PROPERTY DAMAGE, INCLUDING VOIDING OF THE COMPONENT WARRANTY, IF NOT PERFORMED SAFELY AND WITHIN THE PARAMETERS SET FORTH IN THIS MANUAL.

#### **WARNING**

- DO NOT ALLOW CHILDREN TO OPERATE OR TAMPER WITH THE AXIS SHALLOW WATER ANCHOR UNSUPERVISED.
- KEEP HANDS AWAY FROM MOVING ANCHOR PARTS.
- ALWAYS MAINTAIN A SAFE DISTANCE BETWEEN THE ANCHOR AND YOUR EXTREMITIES. AVOID WEARING LOOSE CLOTHING WITHIN CLOSE PROXIMITY OF THE ANCHOR; FAILURE TO DO SO MAY RESULT IN BODILY INJURY.
- ALWAYS DISCONNECT THE 12 VOLT POWER SOURCE FROM THE ANCHOR BEFORE SERVICING.
- KEEP CLEAR OF ANCHOR WHILE EXTENDING AND RETRACTING.
- KEEP ANCHOR CLEAR OF OBSTRUCTIONS.
- DO NOT PERFORM INSTALLATION WHILE BOAT IS IN WATER.
- DO NOT OPERATE BOAT (PUT UNDERWAY) UNTIL THE ANCHOR IS FULLY RETRACTED.
- DO NOT USE YOUR AXIS SHALLOW WATER ANCHOR AS A FORM OF ASSISTANCE FOR ENTERING OR EXITING THE VESSEL.

#### **CAUTION**

THE "CAUTION" SYMBOL ABOVE IS A SIGN THAT A PROCEDURE HAS A SAFETY RISK INVOLVED AND MAY CAUSE PERSONAL INJURY, PRODUCT AND/OR PROPERTY DAMAGE IF NOT PERFORMED SAFELY AND WITHIN THE PARAMETERS SET FORTH IN THIS MANUAL.

#### **CAUTION**

ALWAYS WEAR APPROPRIATE PERSONAL PROTECTION EQUIPMENT (PPE) WHEN PERFORMING SERVICE, MAINTENANCE OR INSTALLATION PROCEDURES.

#### **CAUTION**

MOVING PARTS CAN PINCH, CUT OR CRUSH. KEEP CLEAR AND USE CAUTION.

## Lewmar® Axis™ (Shallow Water Anchor)

Installation and Owner's Manual  
(For Aftermarket Applications)

### Parts List

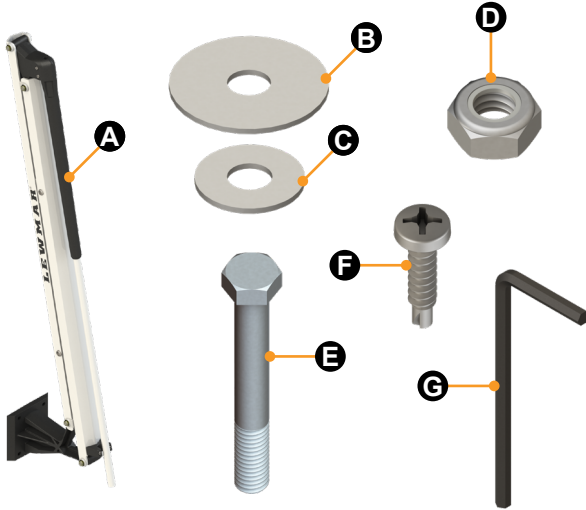

Letter	PN	Description	Qty
A	<a href="#">2022108804</a>	Lewmar Axis Anchor - White	1
	<a href="#">2022108805</a>	Lewmar Axis Anchor - Black	1
B	N/A	Washer, 3/8" x 1 1/2" O.D., SS	4
C	N/A	Washer, 3/8" x 1" O.D., SS	4
D	N/A	Nut, 3/8", Locking, Brass	4
E	N/A	Screw, 3/8" x 3", Hex HD, SS	4
F	N/A	Screw, #6 x 3/4", SLFTP, SS	4
G	N/A	Hex wrench, 7/32"	2

**NOTE:** Part numbers are shown for identification purposes only. Not all parts are available for individual sale. All parts with a link to the Lippert Store can be purchased.

### Resources Required

- 1-2 people, depending on task
- 1/16" wrench
- 1/16" socket with ratchet
- #2 Phillips drive bit or screwdriver
- Flat head screwdriver
- Cordless or electric drill or screw gun
- 1/8", 3/8" and 1/2" drill bits
- Wire cutter/stripper/crimper
- Heat shrink connectors
- Tape measure
- 4-ft straight edge
- Utility knife
- Heat gun
- Marine grade sealant (3M 5200 or similar)
- Non-permanent marker

### Installation

**NOTE:** Lippert recommends the installers be able to lift 35-50 lbs and have an intermediate skill level of mechanical and electrical aptitudes.

#### Determine Transom Mounting Location

1. Cover the intended mounting area with masking tape to prevent scratches and gel-coat chipping when drilling the mounting holes later.
2. The lowest point of the anchor must be mounted above the water line to prevent adverse handling of the vessel (Fig.1).

**NOTE:** If the vessel has trim tabs, make sure there is no interference between the tabs and the anchor before continuing with installation.

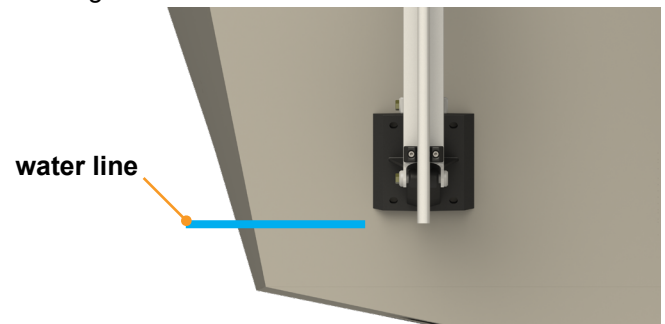

Fig.1

3. With the anchor placed in its desired location, operate the outboard motor through the entirety of its turning and trim range to confirm there is no interference with it and the anchor.

4. If there is no interference with any of the vessel's exterior components, make sure there is enough room within the vessel's interior location around the transom to accommodate tightening of the mounting hardware.

#### Mounting the Anchor

### ⚠ WARNING

**PARTIAL OR SURFACE-MOUNTING OF THE AXIS SHALLOW WATER ANCHOR CAN COME LOOSE OR BREAK FREE FROM THE TRANSOM, RESULTING IN POSSIBLE SEVERE PRODUCT AND/OR PROPERTY DAMAGE, INCLUDING VOIDING OF THE COMPONENT WARRANTY, SERIOUS PERSONAL INJURY OR DEATH. THE AXIS SHALLOW WATER ANCHOR MUST BE SECURELY BOLTED THROUGH THE TRANSOM.**

1. With the help of another person, place the Axis Shallow Water Anchor stern mounting bracket against the transom and mark the location of the four mounting holes (Fig.2A) with a non-permanent marker.

## Lewmar® Axis™ (Shallow Water Anchor) Installation and Owner's Manual (For Aftermarket Applications)

2. Use an 1/8" drill bit to drill four pilot through-holes where previously marked (step 1) (Fig.2A) on the transom.
3. Set the Axis Shallow Water Anchor aside.
4. Use a 3/8" drill bit to drill through the four previously drilled pilot holes (step 2) to open them up.

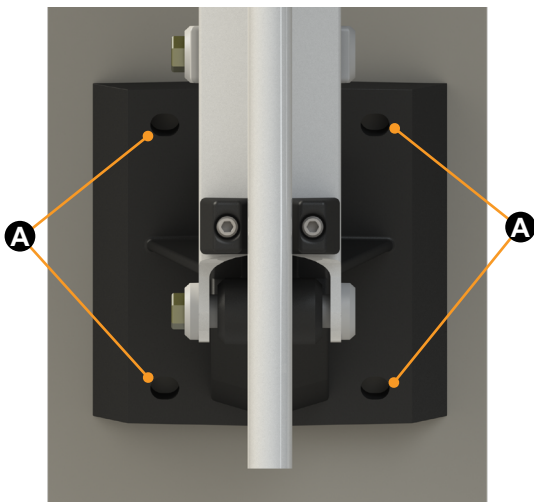

Fig.2

5. Apply a generous amount of marine grade sealant (3M 5200 or similar):

- A. On the mating surfaces of the stern mounting bracket and hull.
- B. All around the 3/8" stern bracket's mounting holes. Make sure to seal the drilled holes toward the inside of the vessel.

6. With the help of another person, retrieve the Axis Shallow Water Anchor and align its stern bracket holes with the transom holes.

- A. Install one 3/8" x 1" O.D. washer (Fig.3A) onto each of the four 3/8"-16 x 3" hex head screws (Fig.3B) then insert from the outside of the vessel the assembled hardware through the previously (step 4) drilled holes in the transom and through the anchor's mounting bracket.

**NOTE:** Proper mounting bracket installation will have each screw hex head facing outside the vessel and the lock nuts facing inward from the inside surface of the transom.

- B. Install one 3/8" x 1 1/2" O.D. washer (Fig.3C) over each of the four screws (Fig.3B) followed by threading on a 3/8"-16 brass lock nut (Fig.3D). Hand-tighten the nuts to hold the Axis Shallow Water Anchor in place.

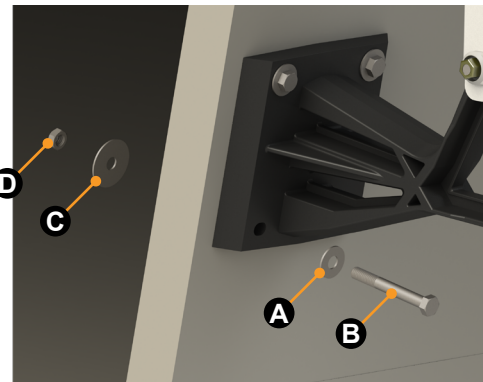

Fig.3

- C. For each installed screw (Fig.3B), hold in place with a 9/16" wrench to keep it from turning, while tightening the lock nut (Fig.3D) with a 9/16" socket and ratcheting wrench. Holding the hex head screw and tightening the lock nut onto it prevents damage to the powder coat of the Axis system.

### Additional Anchor Mounting Brackets

In addition to transom mounting, Aftermarket mounting brackets (sold separately) can be purchased and easily installed to meet a particular mounting need.

- Quick Release Mounting Bracket Kit
- Jack Plate Mounting Bracket Kit
- Engine Mounting Bracket Kit
- Engine Mounting Bracket Kit

Contact a dealer or installer for details.

**NOTE:** Aftermarket mounting bracket hole locations are identical to the standard stern mounting bracket hole locations, so no new holes are required when upgrading.

### Mounting the RF Module

1. Place the RF (radio frequency) module box (Fig.4) in close proximity to the vessel's power source.
2. Hold the RF module in place and, using a non-permanent marker, draw an outline of the box.
3. Using the provided mounting template, it is recommended to pre-drill the four holes for the #6 mounting screws.
  - A. Cut out the provided RF module mounting template (Fig.10).
  - B. Place the template over the previously marked RF module box outline (step 2) and secure it in-place; e.g., tape, tacks.
  - C. Using a drill with an 1/8" drill bit, drill four holes (Fig.10) where indicated on the template.
4. Secure the RF module box in-place with the four provided #6 x 3/4" screws.

### ⚠ NOTICE

**ALL ELECTRICAL WIRING HARNESSES SHALL BE LOOMED AND SECURED TO PREVENT POSSIBLE DAMAGE AND INSTALLED IN ACCORDANCE WITH THE LATEST ABYC (AMERICAN BOAT AND YACHT COUNCIL) ELECTRICAL STANDARDS, E11 AND S31.**

5. Using the appropriate heat shrink connectors (**NOT** supplied), connect the short black lead (Fig.4A) to -12V source and the short red lead (Fig.4B) to +12V source.

**NOTE:** Lippert recommends that the two power leads be connected to a battery switch since the RF module will draw a small amount of power when not in use.
6. Plug the longer black lead (Fig.4C), configured with a quick connect Deutsch Plug, into the receiving plug on the Axis Shallow Water Anchor.

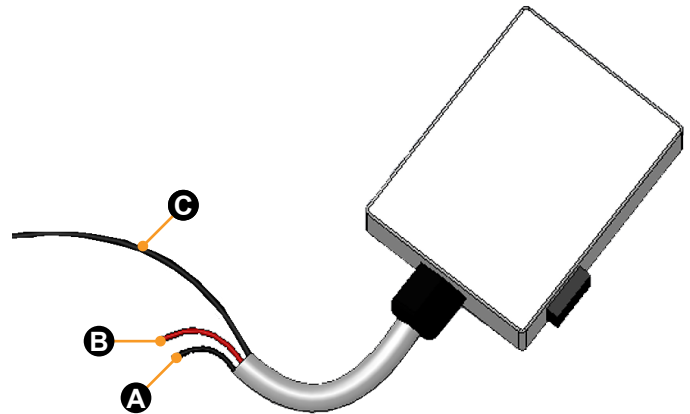

Fig.4

### Programming the RF Module

Determine if momentary or latching functionality is preferred.

**NOTE:** The transmitter and receiver can be configured for momentary or latching operation.

#### For momentary functionality:

- Receiver output remains active as long as the transmitter switch is depressed.
- Receiver output turns off when the transmitter switch is released.

#### For latching functionality:

- Receiver output becomes active as soon as the transmitter switch is depressed and released.
- Receiver output turns off when the transmitter switch is depressed and released again.

Turn on power to the RF module.

1. Remove the four screws (Fig.4A) from the RF Module.
2. Set screws aside for later use.
3. Remove the RF Module lid.
4. Locate the PROGRAM pushbutton switch (Fig.5A) on the receiver.

## Lewmar® Axis™ (Shallow Water Anchor)

Installation and Owner's Manual  
(For Aftermarket Applications)

5. Press and hold the PROGRAM switch until the red LED (Fig.5B) illuminates (approximately three seconds). The receiver is now in the transmitter program mode.

### NOTICE

WHEN USING IN LATCHING MODE, THE ANCHOR AUTOMATICALLY SENSES WHEN IT REACHES SUFFICIENT CONTACT WITH THE SEAFLOOR OR REACHES FULL EXTRACTION. THIS SENSING MOMENTARILY CUTS POWER TO THE MOTOR TO PREVENT DAMAGE. THERE WILL APPROXIMATELY BE A 5-SECOND DELAY BEFORE THE SYSTEM WILL RESPOND TO ANOTHER INPUT FROM THE REMOTE.

6. Release the PROGRAM switch.

At this point, all previously programmed transmitter addresses are erased from the receiver's memory.

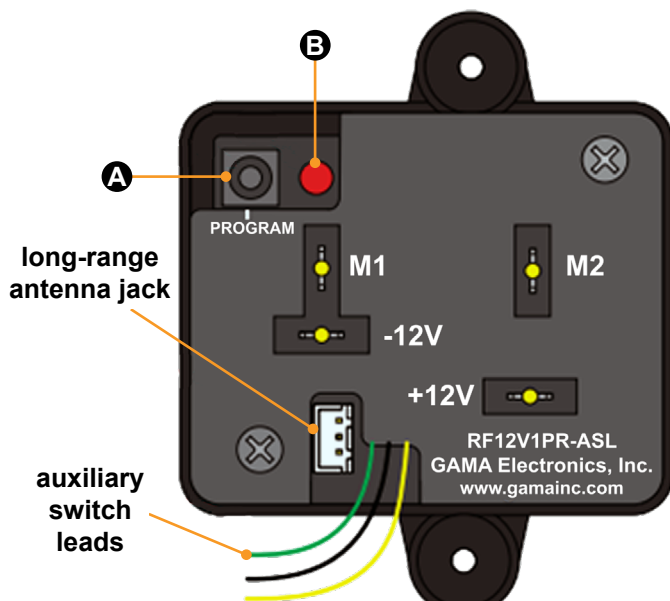

Fig.5  
Programming for Momentary Functionality

1. Press and release a switch on the transmitter.
2. The red program LED on the receiver will blink once.

#### Programming for Latching Functionality

1. Press and release the same switch a second time.
2. The program LED will flash on and off.
3. Repeat previous step 1 for additional transmitters that the receiver needs to respond to.

**NOTE:** The receiver will return to normal mode if no transmitter switches are pressed for five seconds.

4. The red LED on the receiver will flash and then turn off.

5. Reinstall the previously removed (steps 1-3 in the Programming the RF Module section) lid.

RF Module programming is now complete and the receiver is now in normal mode of operation. The receiver will retain all of its programming even when power is removed.

## Operation

Operation of the Axis Shallow Water Anchor can be by the remote control or the RF module's hard mounted switch.

### CAUTION

IF THE AXIS SHALLOW WATER ANCHOR IS NOT FULLY RETRACTED AND PROPERLY STOWED BEFORE PUTTING UNDERWAY, TRAILERING OR TRAVELING, PRODUCT AND/OR PROPERTY DAMAGE MAY OCCUR. MAKE SURE THE AXIS SHALLOW WATER ANCHOR IS IN THE STOWED (FULLY UPRIGHT) POSITION BEFORE PUTTING UNDERWAY, TRAILERING OR TRAVELING.

### CAUTION

LEAVING THE BOAT UNATTENDED WHILE ONLY SECURED BY THE AXIS SHALLOW WATER ANCHOR MAY RESULT IN PRODUCT AND/OR PROPERTY DAMAGE. NEVER LEAVE THE BOAT UNATTENDED WITH THE AXIS SHALLOW WATER ANCHOR AS THE PRIMARY ANCHORAGE.

#### To extend and lower the anchor:

1. If in momentary mode, depress the "down" switch until the anchor spike makes sufficient contact with the waterway's bed.
2. If in latching mode, press the button and the anchor will deploy until the system senses sufficient spike engagement with the waterway's bed.

#### To raise and retract the anchor:

1. If in momentary mode, depress the "up" switch until the anchor spike is raised from the waterway's bed and is fully retracted.
2. If in latching mode, press the same button as before and the anchor will automatically raise up from the waterway's bed and fully retract.

### Troubleshooting

#### **⚠ CAUTION**

DEBRIS CAUGHT AROUND THE AXIS SHALLOW WATER ANCHOR CAN AFFECT PROPER PRODUCT OPERATION. DO NOT CLEAR DEBRIS FROM THE AXIS SHALLOW WATER ANCHOR WITHOUT DISCONNECTING THE 12 VOLT POWER SOURCE OR PERSONAL INJURY MAY OCCUR. DISCONNECT THE 12 VOLT POWER SOURCE PRIOR TO REMOVING ANY OBSTRUCTIONS FROM THE AXIS SHALLOW WATER ANCHOR.

What is happening?	Why?	What should be done?
Anchor does not extend/lower.	Bad electrical connection.	Make sure the Deutsch plug from the RF Module is fully engaged and secured at the anchor's plug.
		Check for loose electrical connections at the power source and at all heat shrink and switch connections. Tighten all loose connections and/or repair connections as necessary.
	No power.	Make sure the Deutsch plug from the RF Module is fully engaged and secured at the anchor's plug.
		Check for disconnected and/or cut wires. Reconnect and/or repair/replace wires as necessary.
		Check electrical connections to the vessel's power source. Make sure power and ground connections to the power source are installed correctly and made secure.
		Check the vessel's power source for voltage level. Fully charge or replace power source as necessary.
		Replace battery in RF remote control.
Dry pivot bushings.	Lubricate all pivot bushings with spray Lithium grease.	
Debris caught around the anchor.	Disconnect the 12 Volt power source. Remove all debris. Reconnect power source.	
Electronic motor failure.	Replace electronic motor. Call Lippert Customer Care Center.	

## Maintenance

### ⚠ CAUTION

USE OF NON-GENUINE AXIS SHALLOW WATER ANCHOR ACCESSORIES MAY RESULT IN PRODUCT AND/OR PROPERTY DAMAGE, INCLUDING VOIDING OF THE COMPONENT WARRANTY. ONLY USE GENUINE AXIS SHALLOW WATER ANCHOR ACCESSORIES.

- Inspect all electrical connections to ensure that they are secure and free of corrosion every three months.
- Inspect all fasteners for proper tightness after every 100 cycles to ensure that the anchor is in safe working condition. Tighten loose fasteners as necessary. Replace damaged fasteners and/or bushings immediately.
- Thoroughly rinse all moving parts with fresh water after each use.
- Lubricate the bushings at both the mounting bracket and knuckle hinge points (Fig.6A) every six months with spray lithium grease.
- Check battery power level before boating. Battery should be maintained at maximum level. The Axis Shallow Water Anchor draws power from the vessel's power source during operation. The average life of a 12 Volt battery with 55 cold cranking amps is 400 cycles per charge. Charge or replace battery as necessary.
- Although the amperage draw on the vessel's battery is negligible, power-off the RF Module via a battery switch when the vessel is stored.

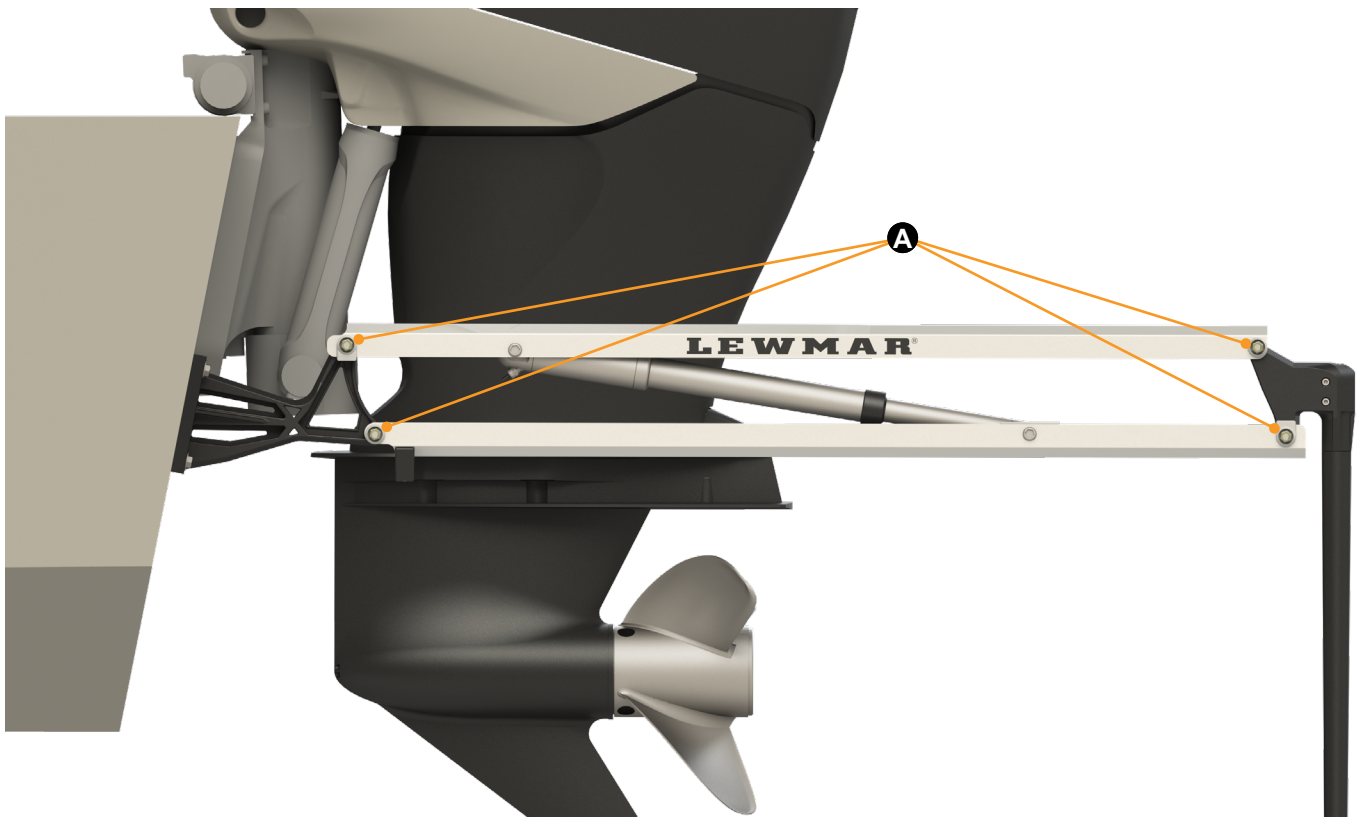

Fig.6



## Lewmar® Axis™ (Shallow Water Anchor) Installation and Owner's Manual (For Aftermarket Applications)

### Manual Override

In the event there is a loss of power to the anchor preventing it from extending or retracting, do as follows:

1. Disconnect the axis anchor Deutsch Plug from the boat's mating connector.
2. Locate the actuator dowel found at the actuator linkage point (Fig.7A).



Fig.7

3. Using the two provided  $\frac{7}{32}$ " hex wrenches (Fig.8A), remove the two  $\frac{3}{8}$ " button head screws (Fig.8B) securing the actuator dowel.

**NOTE:** Depending on the extension state of the system, the same steps may be required for the upper actuator dowel as well.

4. Manually retract the anchor.

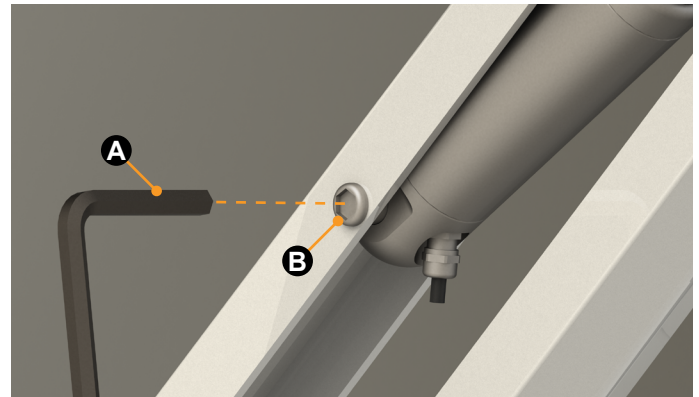

Fig.8

### ⚠ CAUTION

IF THE AXIS SHALLOW WATER ANCHOR IS NOT FULLY RETRACTED AND PROPERLY STOWED BEFORE PUTTING UNDERWAY, TRAILERING OR TRAVELING, PRODUCT AND/OR PROPERTY DAMAGE MAY OCCUR. MAKE SURE THE AXIS SHALLOW WATER ANCHOR IS IN THE STOWED (FULLY UPRIGHT) POSITION BEFORE PUTTING UNDERWAY, TRAILERING OR TRAVELING.

5. Using straps or some other type of cordage, firmly secure the anchor in its upright, stored position (Fig.9) before going underway.

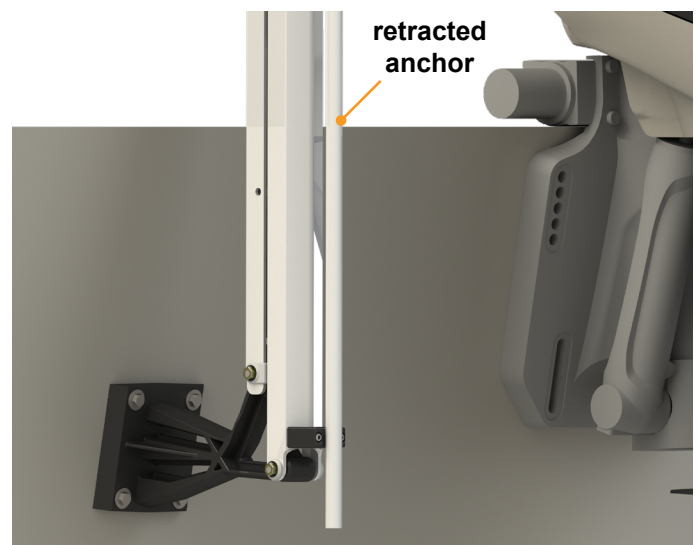

Fig.9

### Warranty Coverage - Components

The following table lists component-specific warranty information.

All listed component warranty coverage times are from date of the item's purchase.

Component Warranty Coverage	
Component	Coverage and Period
Spike	Lifetime warranty
Powder Coat	Six months against cracking, chipping and fading.
Linkage Arms, Mounting Bracket and Knuckle	60 months
Spike Holder and Bushing Hardware	12 months
Remote and RF Module	12 months

**IMPORTANT NOTE:**

**Please retain this label.**

**There is another matching label on the anchor itself.**

**The serial number on the label will be required for all warranty claims.**

## RF Module Mounting Template

**NOTE:** Template outline and mounting holes are to scale when the page is printed **full scale (A4)**. Dimensions are for reference only.

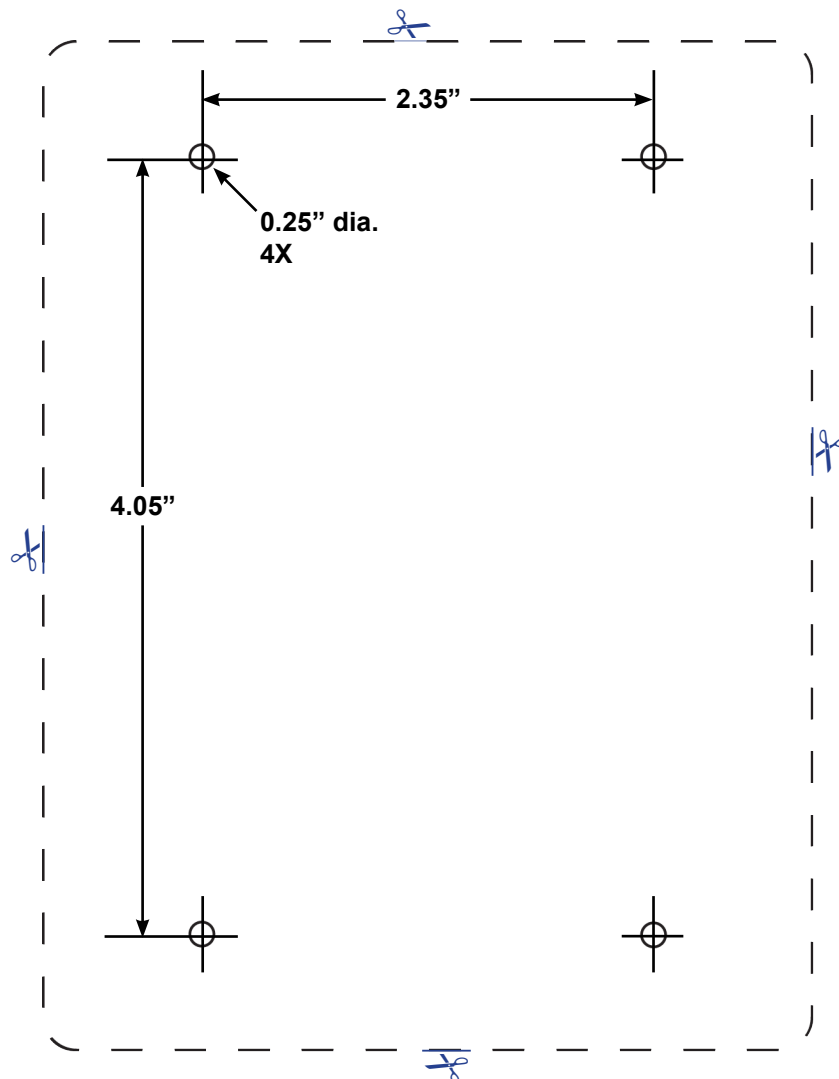

Fig.10



## MARINE GROUP EUROPE



For all concerns or questions, please contact Lippert Customer Care Center

Ph: 432-LIPPERT (432-547-7378)

Email: [customerservice@lci1.com](mailto:customerservice@lci1.com)

Web: [lippert.com](http://lippert.com)

The contents of this manual are proprietary and copyright protected by Lippert. Lippert prohibits the copying or dissemination of portions of this manual unless prior written consent from an authorized Lippert representative has been provided. Any unauthorized use shall void any applicable warranty. The information contained in this manual is subject to change without notice and at the sole discretion of Lippert. Revised editions are available for free download from [lippert.com](http://lippert.com).

Please recycle all obsolete materials.