



SLIMRACK® BED LIFT SYSTEM
OEM INSTALLATION MANUAL

L I P P E R T
C O M P O N E N T S®

TABLE OF CONTENTS

System Information	2
Safety Information	3
Resources Required	3
General Requirements.....	3
Installation	4
SlimRack Bed Lift Assembly.....	4
Wiring Electrical Components.....	5
Motor Harness.....	6
Power Harness.....	6
Switch Harness.....	6
Programming	7
Setting the Lowered Stop Point.....	7
Setting the Raised Stop Point.....	7
Other Installation Information	7
Operation	8
Prior to Moving the SlimRack Bed Lift System:.....	8
Raising the Bed.....	8
Lowering the Bed.....	8
Troubleshooting	9
Override Mode	10
Manual Emergency Lowering Mode.....	10
Preventative Maintenance	11

System Information

The SlimRack® Bed Lift Platform is a rack and pinion design operated by a 12V DC gear motor. The Bed Lift Platform was engineered to provide years of trouble-free service. Changes to weight, stroke, rail position, controller, power supply, etc. all have an effect on the performance of the system.

Features

- Rocker switch that mounts to the wall allows bed movement and provides end user feedback.
- The control box has programmable stops that can detect faults and control the bed lift movement.
- Horizontal channel with 12V DC gear motor and gear rack arms that mounts onto the top and bottom of the bed platform.
- Provided wiring harnesses to connect the touch pad, motors and control box.

Additional information about this product can be obtained from www.lci1.com/support or by downloading the free myLClapp. The app is available on iTunes® for iPhone® and iPad® and also on Google Play™ for Android™ users. iTunes®, iPhone® and iPad® are registered trademarks of Apple Inc. Google Play™ and Android™ are trademarks of Google Inc.

Safety Information

WARNING

Always make sure that the bed lift platform path is clear of people and objects before and during operation of the bed lift.

WARNING

Do not work on your bed lift system unless the battery is disconnected. Failure to act in accordance with the following may result in death or serious personal injury.

WARNING

Always wear eye protection when performing service or maintenance to the vehicle. Other safety equipment to consider would be hearing protection, gloves and possibly a full face shield, depending on the nature of the service.

CAUTION

Moving parts can pinch, crush or cut. Keep clear and use caution.

Resources Required

- 1 to 4 People Depending on Task
- Cordless or Electric Drill or Screw Gun
- Appropriate Drive Bits
- #10 X 1 1/4" Pan Head Screws
- Speed Square (Optional)
- Non-Permanent Method of Marking

General Requirements

- Power and wiring must be such that there is not less than 10.5 running volts supplied at the motor leads under maximum load.
- SlimRack® Bed Lift controls must come from LCI. Controls supplied by other companies will void warranty.
- Voltage supply must come from a 12V DC automotive/RV type battery.

Installation

SlimRack Bed Lift Assembly

1. On one side of the bed platform measure $\frac{1}{4}$ " from the top of the bed platform down and mark the location. Measure in several locations from the top of the bed platform down and draw a level horizontal line (Fig. 1A) connecting the measured locations.
2. On the same side of the bed platform, measure $\frac{1}{4}$ " from the bottom of the bed platform up and mark the location. Measure in several locations from the bottom of the bed platform up and draw a level horizontal line (Fig 1F) connecting the measured locations.
3. Align the SlimRack® rack arm bracket ends (Fig. 1B and Fig. 1E) on the side of the bed platform at the marked lines. Ensure the brackets are evenly spaced vertically on the bed platform wall and at a 90° angle to the SlimRack® horizontal column (Fig. 1C).

NOTE: Even spacing between the gear rack arms (Fig. 1D) is critical for proper operation of the SlimRack® Bed Lift. Measure from the top gear arm bracket to the other top gear arm bracket and note the distance. Ensure that the bottom brackets are at the same distance as the top. Use an optional speed square to ensure that the gear rack arms are at a 90° angle to the SlimRack® horizontal column.

4. Attach the SlimRack® gear rack arm brackets to the side of the bed platform at the previously marked locations with #10 X $1\frac{1}{4}$ " pan head screw, making sure that the motor in the horizontal channel is located towards the exit end of the unit.
5. Repeat steps 1-4 for the opposite side.
6. Lift bed platform into the base (4 people recommended) and set bed platform on top of the base opening. The SlimRack® column will be resting on top of the base opening.
7. Fasten the SlimRack® horizontal columns to the base opening using the pre-drilled holes (Fig. 2A) on the SlimRack® assembly with #10 X $1\frac{1}{4}$ " pan head screw on both sides of bed platform.

Fig. 1

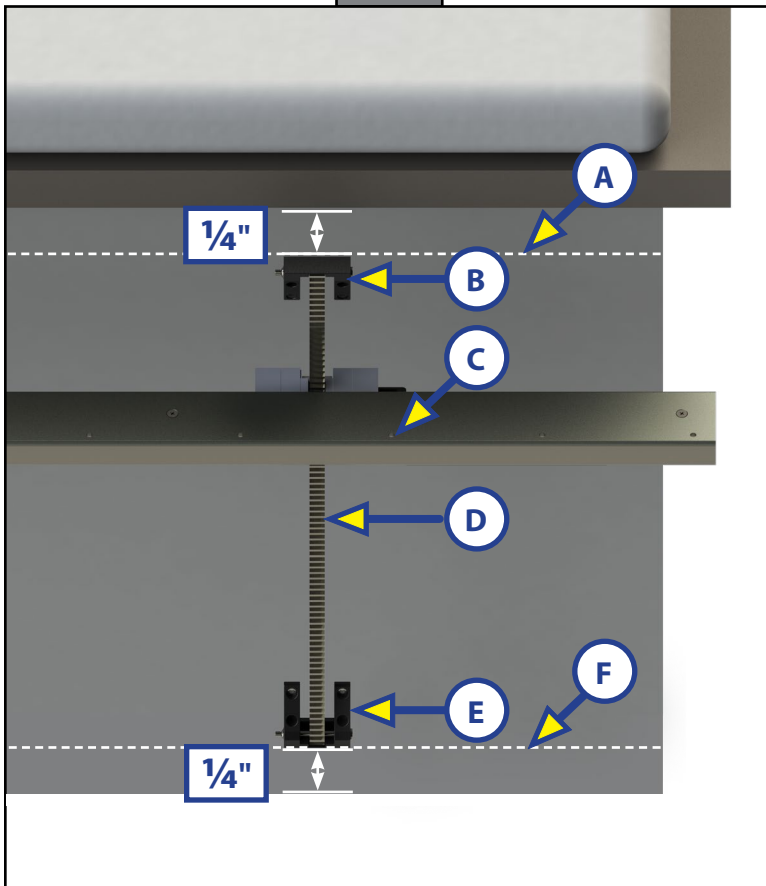
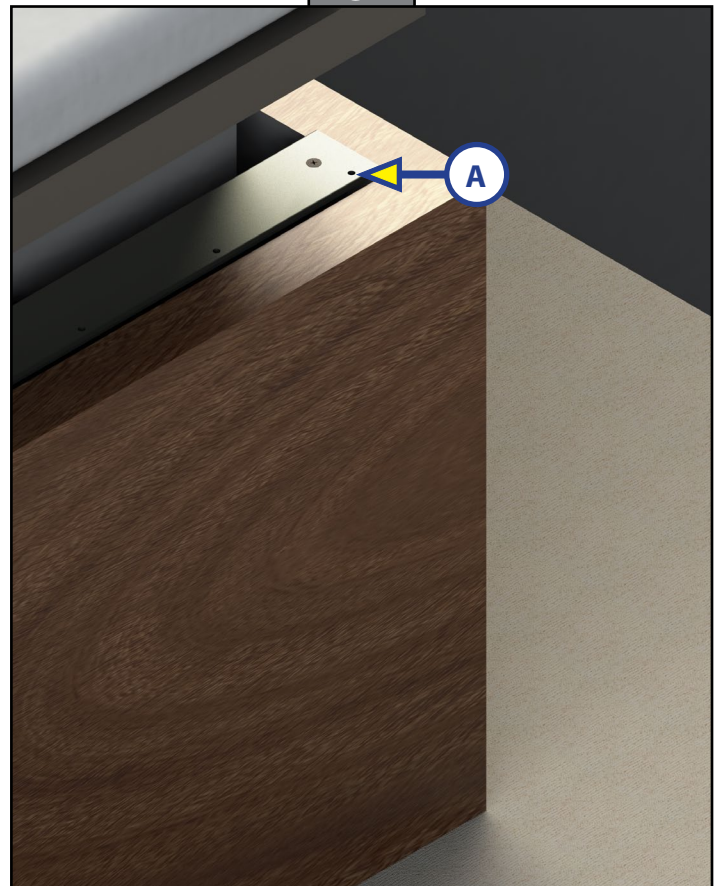

Fig. 2



Wiring Electrical Components

1. Mount the controller (Fig. 3) in a clean and dry, weather tight location that will keep it from being damaged, but is easily accessible for service. The controller is not waterproof.

NOTE: LCI recommends inside a luggage door or storage compartment for the controller placement.

2. Determine location to mount the rocker switch (Fig. 4). The location needs to be in view of the Bed Lift System and have minimum depth of 1" inside the wall.
3. Route and attach the switch harness (Fig. 3A) to where the rocker switch will be mounted and mount the rocker switch with 2 screws.
4. Route the motor/sensor harnesses (Fig. 3B and Fig. 3C) from the SlimRack® Bed Lift motors to the control box. When identifying motor 1 and motor 2, refer to Fig. 6.

NOTE: It is important that the SlimRack® Bed Lift motors be plugged in to the proper receptacle at the control box.

5. Route and attach the pigtail control power harness (Fig. 3D) from the control to the 12V DC battery. It is recommended that this circuit be protected with a 30 amp fuse. Wire must be sized so that a minimum of 12.5 V DC is measured at the control while under load. See chart (Fig. 5) for proper wire gauge to use.

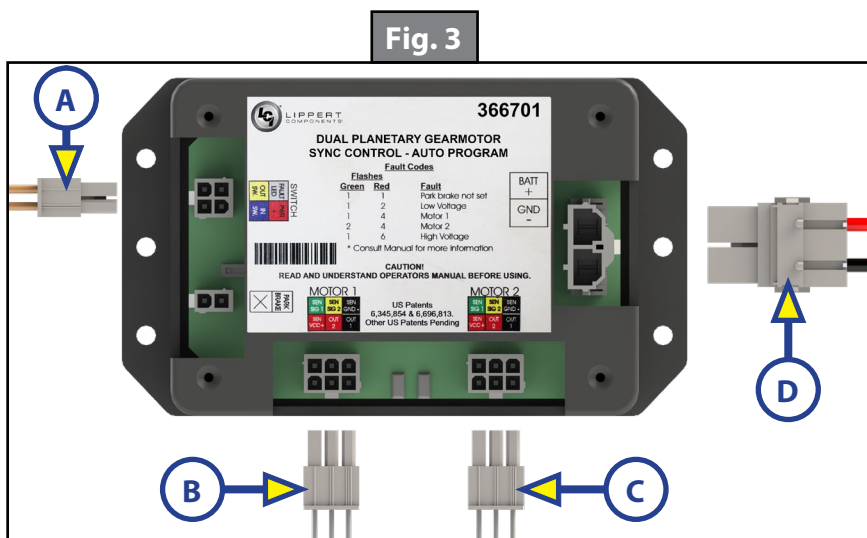
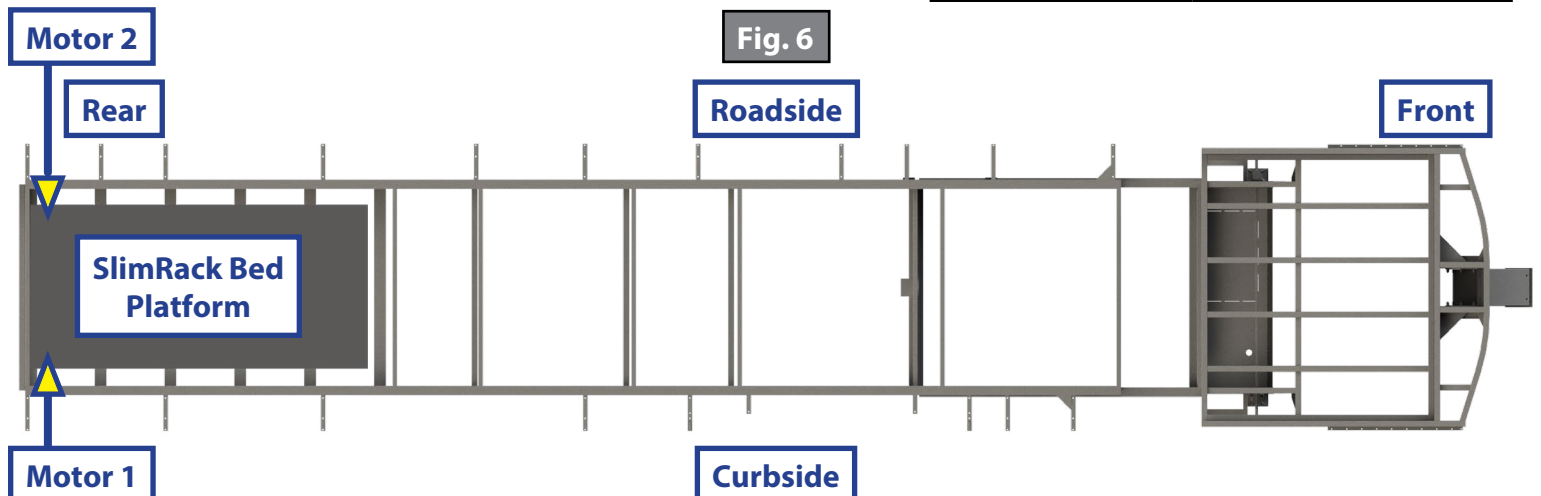
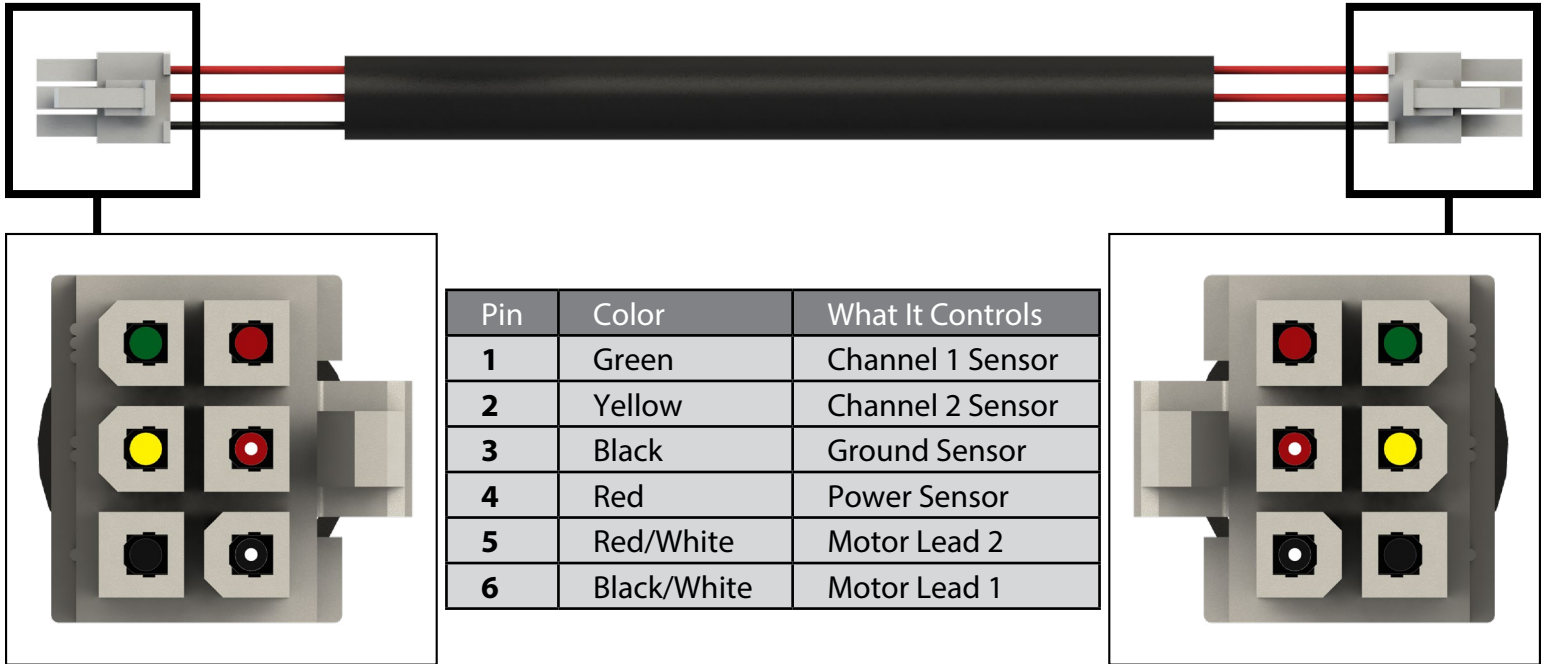

Fig. 5

Wire Gauge	Maximum Length
16	10 feet
14	15 feet
12	25 feet
10	40 feet



Motor Harness



Power Harness

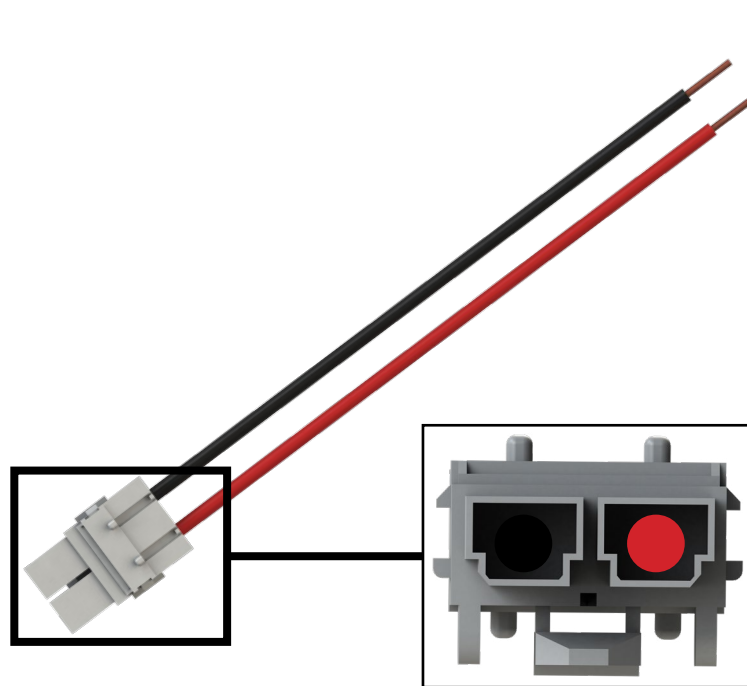

Switch Harness

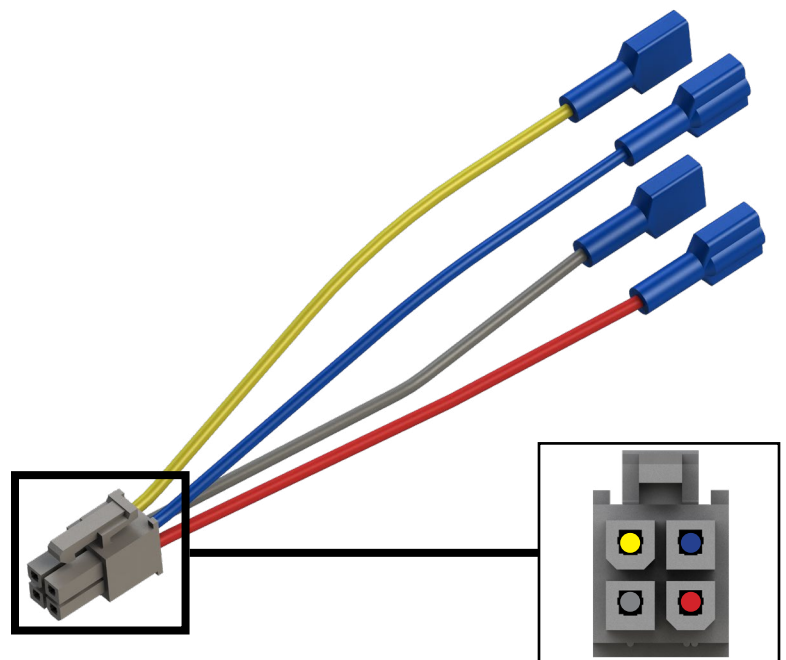

Pin	Color	What It Controls
1	Black	Ground
2	Red	Power

Pin	Color	What It Controls
1	Gray	Fault Code LED
2	Red	Switch Power
3	Yellow	Switch Out
4	Blue	Switch In

NOTE: If the wall rocker switch is not supplied by LCI, the gray wire on the 4 wire switch harness is not utilized.

Programming

NOTE: When raising or lowering the bed, the switch will need to be depressed and held for 2 seconds after the bed stops moving. Failure to do so will cause the stops to NOT set.

⚠ WARNING

Always make sure that the Bed Platform Lift path is clear of people and objects before and during operation of the Bed Platform Lift. Always keep away from the slide rails when the bed is being operated. The gear assembly may pinch or catch on loose clothing causing personal injury.

Setting the Lowered Stop Point

1. Press and hold the IN button on the wall rocker switch (Fig. 7B).
2. Move the bed to the fully lowered position. Press and hold the IN button for 2 seconds after the bed stops moving. Release the wall switch.
3. Visually inspect the bed platform to make certain the bed is fully lowered. If it is not, push and hold the IN button until fully lowered. This procedure may need to be repeated until both sides of the bed platform are fully lowered.

Setting the Raised Stop Point

1. Press and hold the OUT button on the wall rocker switch (Fig. 7A).
2. Move the bed to the fully raised position. Press and hold the OUT switch for 2 seconds after the bed stops moving. Release the wall switch.
3. Visually inspect the bed platform to make certain the bed platform is fully raised. If it is not, push and hold the OUT button until fully raised. This procedure may need to be repeated until both sides of the bed platform are fully raised.

Other Installation Information

The control box is equipped to help troubleshoot the system during installation. Count the number of LED flashes and refer to the Fault Code Flashes Chart under the Troubleshooting section of this manual or on the label of the control box.

NOTE: It is important that the SlimRack® motors be plugged in to the proper receptacle at the control box. See (Fig. 3 and Fig. 6) for proper motor designation. Failure to properly connect the motors to the control will result in problems for future troubleshooting. (The control will identify the incorrect motor during a fault).

NOTE: 12V DC battery to the control box is required to set stops. If in a non-motorized unit ensure batteries are charged to 12 volt or greater.

If you are still having difficulties programming the system (and prior to replacing the control), verify that the system has been wired correctly and that the lowered stop location was programmed BEFORE the raised stop location. See (Fig. 3) for proper connection of the motors to the SlimRack® Bed Lift control.

Fig. 7

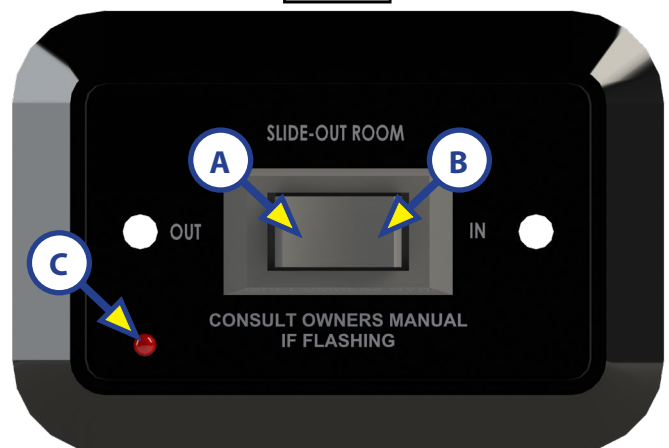

Operation

⚠ WARNING

Always make sure that the SlimRack® Bed Lift path is clear of people and objects before and during operation of the SlimRack® Bed Lift. Always keep away from the slide rails when the bed is being operated. The gear assembly may pinch or catch on loose clothing causing personal injury.

Prior to Moving the SlimRack Bed Lift System:

- Make sure the engine or generator is running to ensure ample voltage is being supplied to the SlimRack® bed lift control box. If in a non-motorized unit ensure batteries are charged to 12V or greater.
- Set the parking brake, if applicable.

Raising the Bed

1. The engine or generator must be running, or unit must be plugged into shore power.
2. Transmission must be in park or neutral (if applicable).
3. Set the park brake (if applicable) and level the unit.
4. Press and hold the OUT button (Fig. 7A). There will be a slight delay before the bed will begin to move. This is normal.
5. Release the button when the bed is fully raised (Fig. 8) and stops moving.

Lowering the Bed

1. The engine or generator must be running, or the unit must be plugged into shore power.
2. Transmission must be in park or neutral (if applicable).
3. Set the park brake (if applicable) and level the unit.
4. Press and hold the IN button (Fig. 7B). There will be a slight delay before the bed will begin to move, this is normal.
5. Release the button when the bed is fully lowered (Fig. 9) and stops moving.

NOTE: When lowering the SlimRack® Bed Lift make sure that the garage area is clear of people and objects.

Fig. 8

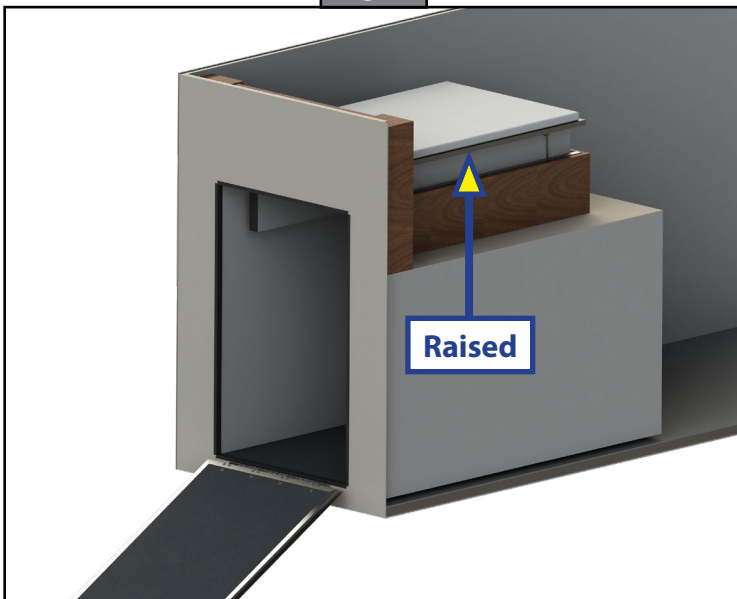
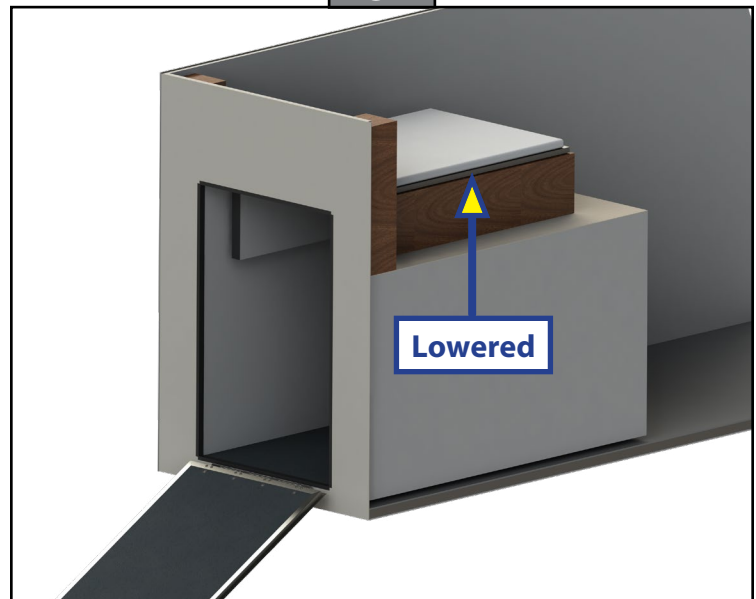

Fig. 9



Troubleshooting

This control has the ability to detect and display several faults. When a fault is detected, the room movement may stop and 2 different LEDs on the control box will flash in a pattern.

- The Fault Code LED (Fig. 7C) on the rocker switch will flash RED a number of times corresponding to the number of red flashes on the control box (Fig. 10A). Refer to the troubleshooting chart below to best determine what caused the fault.
- The Motor LED (Fig. 10B) on the control box will flash GREEN a number of times corresponding to which motor had the associated fault. For example: 2 GREEN flashes and 4 RED flashes means there is a motor fault on motor 2.

NOTE: For major faults, the control will automatically enter "Emergency Jog" mode when motor movement is not detected by the control box in either direction during bed actuation. When in "Emergency Jog" mode, the control will jog both motors in the direction the rocker switch is pressed (IN or OUT). The rocker switch may need to be pressed multiple times to fully retract or extend the bed. Take the unit to an OEM authorized dealer for service.

NOTE: The control box will return to normal operation mode after 5 minutes of inactivity or by cycling power to the control box.

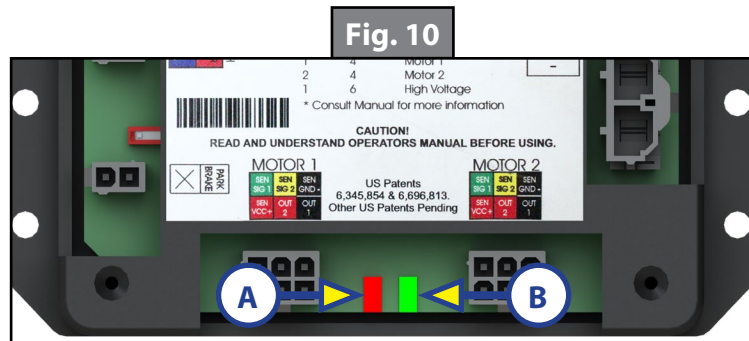

Fault Code Flashes		Fault Type	Description	Why?	What Should Be Done?
Green Flash	Red Flash				
1	1	Minor	Park Brake Not Set	Park Brake not set (if applicable). Ground signal lost at park brake receptacle at control box.	Set parking brake (if applicable). Check for continuity to ground on wire plugged into park brake receptacle at control box.
1	2	Minor	Low Voltage	Incoming voltage to control is below 12.0 VDC. The room will NOT move if the voltage is 10.5 VDC or below.	Start vehicle, generator, or ensure coach is plugged into shore power. Check 2-pin power connector at control box at BATT + and GND. Consult manufacturer of unit charging system for troubleshooting assistance.
1	4	Major	Motor 1 Fault	Bad wire connection Bad motor	Refer to TIP Sheet 82-S0533 for troubleshooting.
2	4	Major	Motor 2 Fault	Bad wire connection Bad motor	
1	6	Minor	High Voltage	Supply voltage to control box is 17 VDC or greater.	Consult manufacturer of unit charging system for troubleshooting assistance.

Override Mode

In the event of component failure or loss of system power, your Bed Platform Lift can be manually overridden and lowered for travel.

NOTE: At any time during the override procedure, the unit will exit this mode if the bed has not been moved for five (5) minutes.

NOTE: For major faults, the control will automatically enter "Emergency Jog" mode when motor movement is not detected by the control box in either direction during bed actuation. When in "Emergency Jog" mode, the control will jog both motors in the direction the rocker switch is pressed (IN or OUT). The rocker switch may need to be pressed multiple times to fully retract or extend the bed. Take the unit to an OEM authorized dealer for service.

NOTE: The control box will return to normal operation mode after 5 minutes of inactivity or by cycling power to the control box.

Manual Emergency Lowering Mode

⚠ WARNING

Before removing the motors ensure the SlimRack® Bed Lift platform is supported with a T-block and a floor jack. Failure to act in accordance with the following may result in death or serious personal injury.

In the event that power is lost to the SlimRack® Bed Lift motors, the bed can be manually lowered by following these steps:

1. Support the bed lift platform with a T-block and a floor jack in the inside middle of the bed platform.
2. Gain access to the motors from the bottom sides of the bed lift platform to the horizontal channel assembly. The motor in the channel is currently located toward the exit end of the trailer.
3. Remove the end of the retaining spring from the motor spring clip (Fig. 11A).
4. Unplug the motor from the harness and remove the motor by lifting it up and out.
5. Repeat steps 1-4 for the other side.
6. Carefully lower the bed lift platform with the floor jack and T-block until the bed lift is in the lowered position.

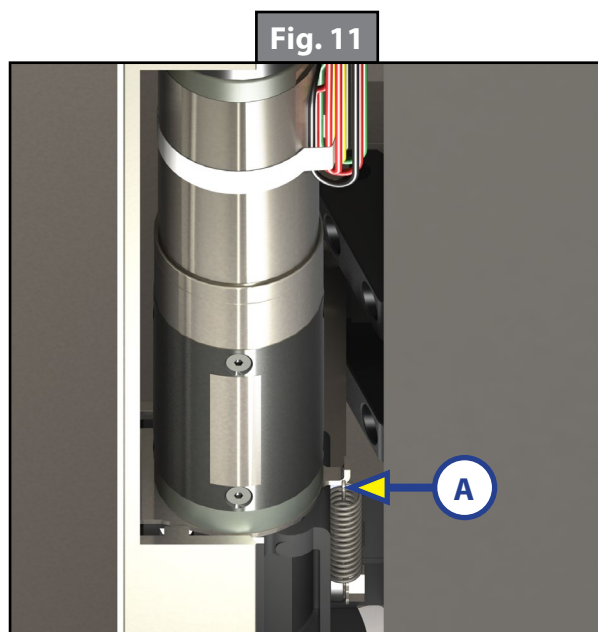

7. Secure the bed in place by re-installing the motors. Make sure the end of the retaining spring is re-hooked to the motor spring clip (Fig. 11A).
8. Have the SlimRack® Bed Lift serviced by the OEM authorized dealer as soon as possible. Do not operate bed until service is complete, as damage to the bed may result.

NOTE: For major faults, the control will automatically enter "Emergency Jog" mode when motor movement is not detected by the control box in either direction during bed actuation. When in "Emergency Jog" mode, the control will jog both motors in the direction the rocker switch is pressed (IN or OUT). The rocker switch may need to be pressed multiple times to fully lower the bed. Take the unit to an OEM-authorized dealer for service.

Preventative Maintenance

Your SlimRack® Bed Lift system has been designed to require very little maintenance. To ensure the long life of your SlimRack® Bed Lift system, read and follow these few simple procedures:

- When the bed is raised, visually inspect the slide rail assemblies. Check for excess buildup of dirt or other foreign material. Remove any debris that may be present.
- If the system squeaks or makes any noises, blow out any debris from the gear rack arms and apply a dry lubricant to prevent and/or stop squeaking.



L I P P E R T C O M P O N E N T S[®]

The contents of this manual are proprietary and copyright protected by Lippert Components, Inc. ("LCI"). LCI prohibits the copying or dissemination of portions of this manual unless prior written consent from an authorized LCI representative has been provided. Any unauthorized use shall void any applicable warranty. The information contained in this manual is subject to change without notice and at the sole discretion of LCI. Revised editions are available for free download from lci1.com.

Please recycle all obsolete materials.

For all concerns or questions, please contact
Lippert Components, Inc.

Ph: (574) 537-8900 | Web: lci1.com | Email: customerservice@lci1.com