



**IN-WALL<sup>®</sup> SLIDE-OUT  
SHIPPED IN BOX OR TUBE  
ASSEMBLY MANUAL**

**L I P P E R T  
C O M P O N E N T S<sup>®</sup>**

# TABLE OF CONTENTS

System Information	2
Safety Information	2
Resources Required	2
Motor Removal	2
Timing Procedure	3
Installing Shipping Angles	5

## System Information

The Lippert Components, Inc. In-Wall® Slide-Out System can now be shipped disassembled at the large components level. This means that some assembly will be required prior to the installation of the In-Wall® Slide-Out System onto the slide-out room. The following instructions are supplied as a guide to the proper assembly of the shipped components for the best possible functioning and operation of the In-Wall® Slide-Out System. This manual is to be used in conjunction with the In-Wall® Slide-Out OEM Installation Manual.

## Safety Information



**Moving parts can pinch, crush or cut. Keep clear and use caution during assembly.**

## Resources Required

- Cordless or electric drill or screw gun
- Appropriate drive bits

## Motor Removal

**NOTE:** LCI recommends that the assembly be done on a clear workbench to prevent damage to the system.

1. In order to install the gear racks, the motor needs to be removed. The motor is held in place by a retention screw (Fig. 1A). It is typically located on the exterior side of the column, near the motor ventilation holes (Fig. 1). Removal of the retention screw will allow the motor to easily slide out of the column.
2. Set the motor and screw aside for later re-assembly.

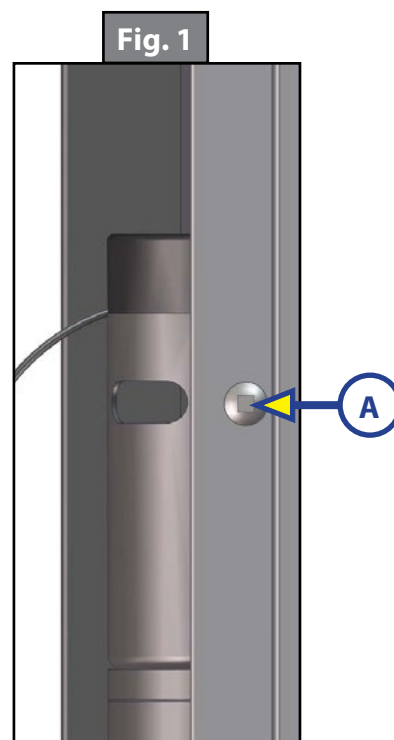

## Timing Procedure

The top and bottom gear racks on each side of the In-Wall Slide-Out System are connected by a torque shaft that runs from the upper bearing block to the lower bearing block. The bearing blocks and torque shaft are mounted inside of the column. The column is fastened to the side wall opening of the unit. The timing of the system from top to bottom is considered to be adjustment free, as it is essentially locked in correct time. In the instance that the system is not timed properly, either the top or the bottom will extend farther than its opposite. The following procedure will help to set system timing.

1. Place the wider side of the H-column flat on a level surface.
2. Closest to the motor end, slide the notched side of the gear rack (Fig. 2A) onto the shoe of the upper bearing block (Fig. 2B) until the spur gear is engaged. Add the shoes if not installed or have dislodged. If not installed or dislodged, slide shoe onto the foot of the bearing block (Fig. 3).

**NOTE:** Make sure that the 2 tabs are pushed down so that they don't get cut off when sliding the gear rack down.

3. For the lower gear rack, slide the notched side of the gear rack (Fig. 4A) onto the shoe of the lower bearing block (Fig. 4B) until the spur gear is engaged.

**NOTE:** The lower gear rack will have the angle shape to allow for the gear rack to be butted up to the bottom of the slide room during installation.

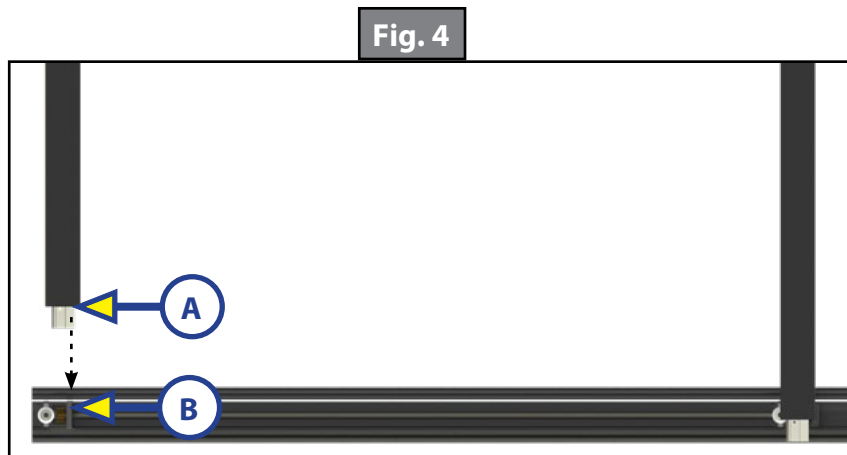
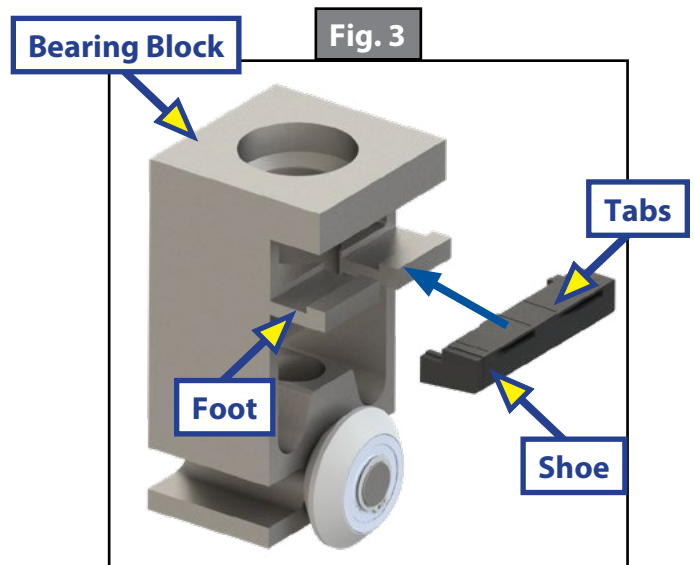
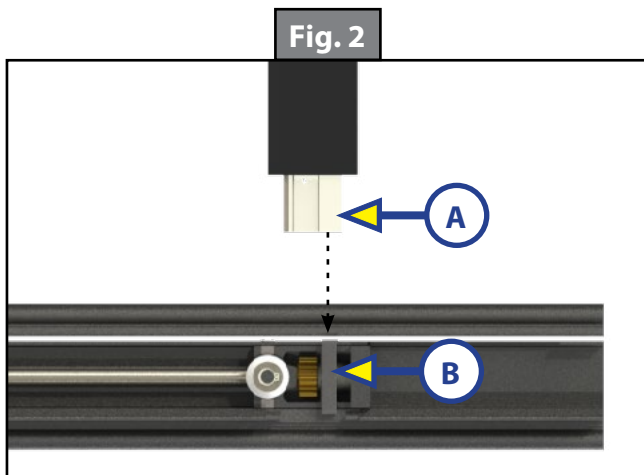

4. Hand turn the torque shaft (Fig. 5A) until both gear racks move up and both gear racks are located at the initial stage on the spur gear.
5. Apply downward pressure to one of the gear racks. This will cause both gear racks to move simultaneously on their respective spur gear. At this point, the gear racks will be synchronized.
6. Move the gear racks on the H-column to an approximate center location. Make sure the H-column is not covering any screw holes of the gear rack.
7. Re-install the motor and retention screw into the H-column.
8. Once both gear racks are engaged, use a tape measure and measure from the column to the end of each gear rack. The measurements must be the same to ensure that the slide room will be timed correctly.
9. Repeat steps 1-8 for the other In-Wall Slide-Out assembly.

Fig. 5

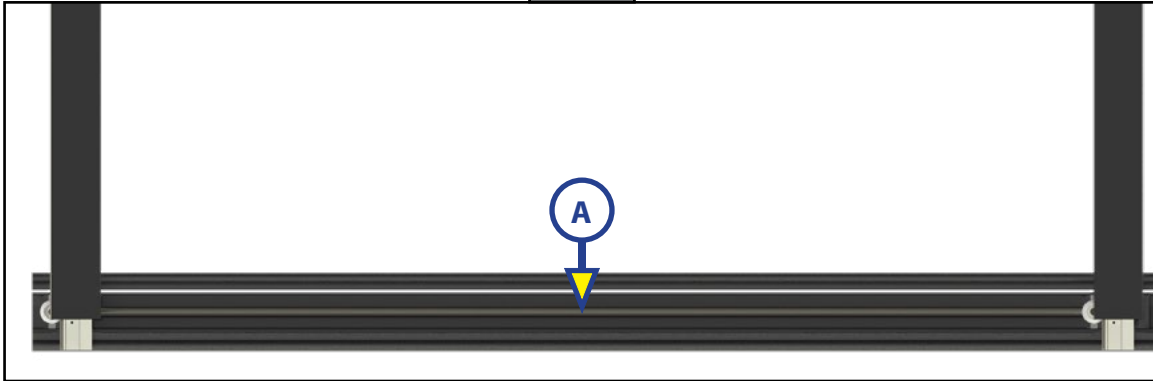

## Installing Shipping Angles

1. On the exterior side of the H-column, place a shipping angle (Fig. 6A) at both ends of the upper and lower gear racks (Fig. 6B). See Fig. 6 details for orientation of the shipping angles on the gear racks.
2. Align the pre-drilled holes in the shipping angle with the pre-drilled hole on the face of the notched end and the extruded hole on the end of the non-notched end.
3. Secure the shipping angles to the gear racks with provided screws.

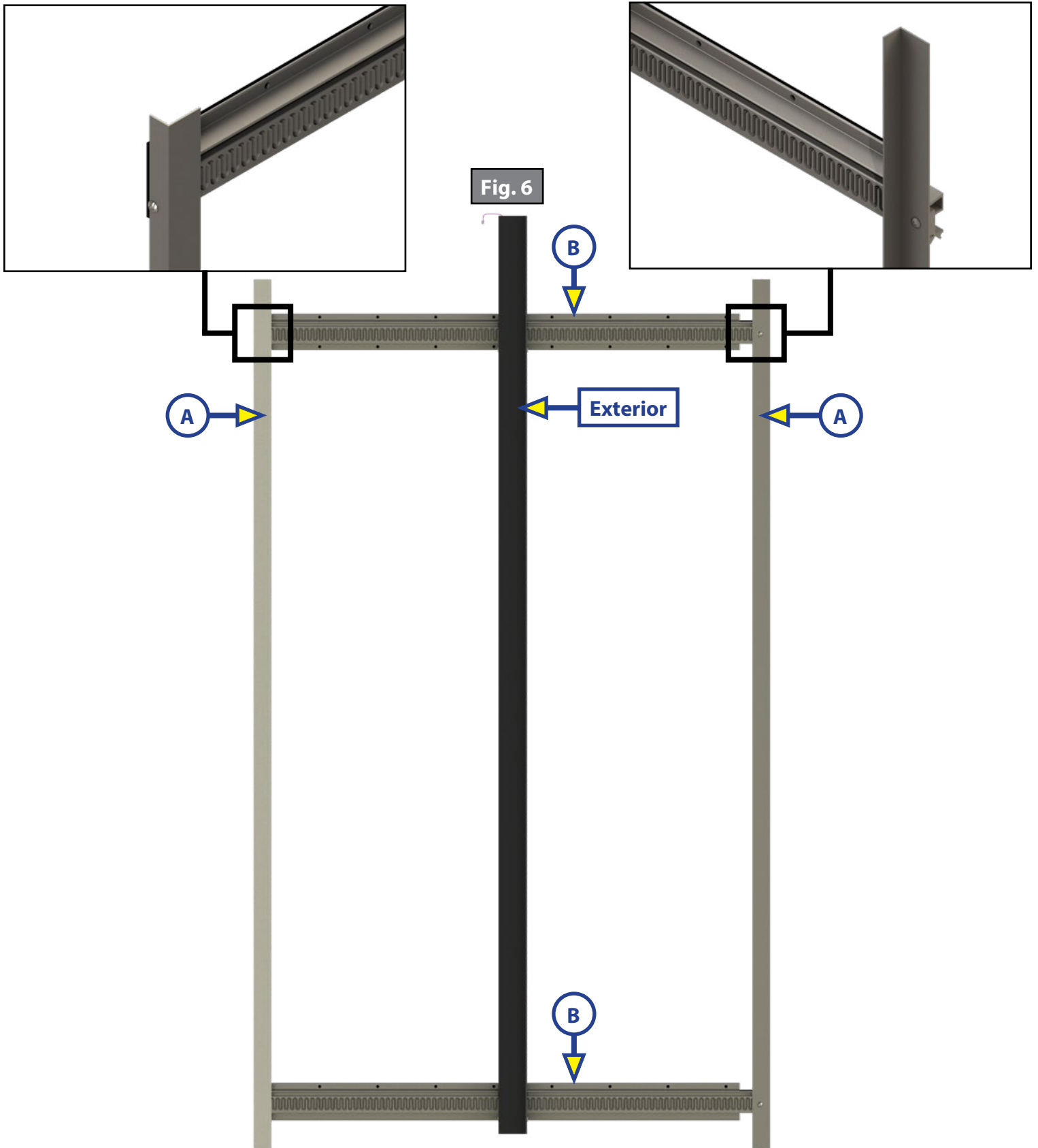



# L I P P E R T C O M P O N E N T S®

The contents of this manual are proprietary and copyright protected by Lippert Components, Inc. ("LCI"). LCI prohibits the copying or dissemination of portions of this manual unless prior written consent from an authorized LCI representative has been provided. Any unauthorized use shall void any applicable warranty. The information contained in this manual is subject to change without notice and at the sole discretion of LCI.

Revised editions are available for free download from [lci1.com](http://lci1.com).

Please recycle all obsolete materials.

For all concerns or questions, please contact  
Lippert Components, Inc.

Ph: (574) 537-8900 | Web: [lci1.com](http://lci1.com) | Email: [customerservice@lci1.com](mailto:customerservice@lci1.com)