



**ELECTRIC THROUGH FRAME
SLIDE-OUT SYSTEM
SERVICE MANUAL**

TABLE OF CONTENTS

Warning, Safety, and System Requirement Information	3
Description.....	3
Safety Information.....	3
Prior to Operation	4
Operation	4
Extending Slide-Out Room.....	4
Retracting Slide-Out Room.....	4
Maintenance	5
Inspection.....	5
Electrical System Maintenance.....	5
Mechanical Maintenance.....	5
Troubleshooting	6
Troubleshooting Introduction.....	6
Comparing 14.5° and 20° Rack and Pinion Gears	7
Spur Gear Comparison.....	7
Gear Pack Replacement Instructions	8
Corrective Action for Squeaking Gear Packs	9
Removing and Replacing Actuator (Fig. 14)	10
Motor Troubleshooting	11
Old Slide-Out Switch Wiring Diagram	12
New Slide-Out Switch Wiring Diagram.....	12
Room Bar Measurement Chart	13
Instructions.....	13
Mechanical Room Adjustment	14
Horizontal Adjustment.....	14
Vertical Adjustment.....	14
Adjusting room so it seals in the IN position.....	15
Adjusting room so it seals in the OUT position.....	15
Manual Override	16
Manual Override - Outside Frame.....	16
Manual Override - Inside Frame.....	17

Warning, Safety, and System Requirement Information

Description

The Lippert Electric Through Frame Slide-out System is a rack and pinion guide system, utilizing an electric ball screw actuator to move the room assembly. The motor drives the ball screw in a forward and backward motion to move the slide room in and out. The actuator comes equipped with an automatic clutching system. The Lippert Electric Slide-out System is designed to operate as a negative ground system.

Safety Information

WARNING

The “WARNING” symbol above is a sign that a service or maintenance procedure has a safety risk involved and may cause serious injury or death if not performed safely and within the parameters set forth in this manual.

Always wear eye protection when performing service or maintenance to the vehicle. Other safety equipment to consider would be hearing protection, gloves and possibly a full face shield, depending on the nature of the service.

This manual provides general service and maintenance procedures. Many variables can change the circumstances of the service procedure, i.e., the degree of difficulty involved in the service operation and the ability level of the individual performing the operation. This manual cannot begin to plot out procedures for every possibility, but will provide the general instructions for effectively servicing the vehicle. In the event the skill level required is too high or the procedure too difficult, a certified technician should be consulted before performing the necessary service. Failure to correctly service the vehicle may result in death, injury or voiding the warranty. The owner’s manual for your unit may have more procedures for service and maintenance.

The Lippert Through Frame Slide-out System is intended for the sole purpose of extending and retracting the slide-out room. Its function should not be used for any other purpose or reason than to actuate the slide-out room. To use the system for any reason other than what it is designed for may result in death, serious injury or damage to the unit.

WARNING

Failure to act in accordance with the following may result in death or serious personal injury.

Before actuating the system, please keep these things in mind:

1. Parking locations should be clear of obstructions that may cause damage when the slide-out room is actuated.
2. Be sure all persons are clear of the unit prior to the slide-out room actuation.
3. Keep hands and other body parts away from slide-out mechanisms during actuation. Death or serious injury may result.
4. To optimize slide-out actuation, park unit on solid and level ground.

Prior to Operation

Prior to operating the Lippert Through Frame Slide-out System, follow these guidelines:

1. Unit should be parked on the most level surface available.
2. Leveling or stabilizing system should be actuated to ensure unit will not move during operation of slide-out system.
3. Be sure battery is fully charged.
4. Be sure to keep all persons and pets clear of slide-out system during operation.

⚠ CAUTION

Always make sure that the slide-out room path is clear of people and objects before and during operation of the slide-out room. Always keep away from the slide rails when the room is being operated. The gear assembly may pinch or catch on loose clothing causing personal injury.

NOTE: Install transit bars (if so equipped) on the slide-out room during storage and transportation.

Operation

Extending Slide-Out Room

1. Level Unit.
2. Verify the battery is fully charged and hooked up to the electrical system.
3. Remove transit bars (if so equipped).
4. Press and hold the IN/OUT switch in the OUT position (Fig. 1B) until room is fully extended and stops moving.
5. Release switch, which will lock the room into position.

NOTE: Only hold OUT switch until room stops.

Retracting Slide-Out Room

1. Verify the battery is fully charged and hooked up to the electrical system.
2. Press and hold the IN/OUT switch in the IN (Fig. 1A) position until the room is fully retracted and stops moving.
3. Release the switch. This will lock the room into position.
4. Only hold IN switch until room stops.
5. Install the transit bars (if so equipped).

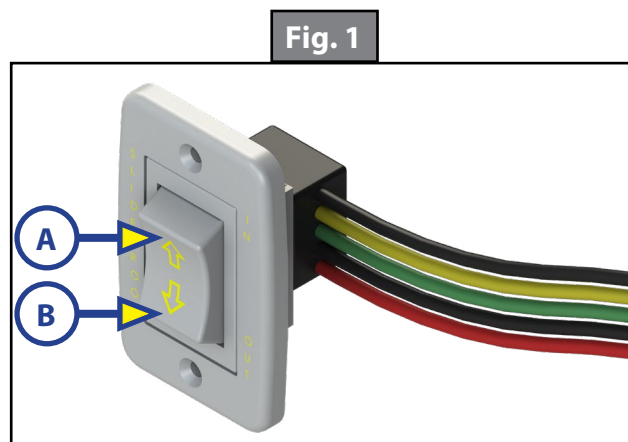

Maintenance

Inspection

After servicing the slide-out system in any way, be sure to check the following:

1. Slide-out stops are installed and adjusted properly.
2. Head assemblies are installed and adjusted properly.
3. System is mounted properly.
4. Cross shafts are mounted properly and clear all other components.
5. Gear packs function properly.
6. Manual override is accessible.
7. Outside seals compress when slide-out is retracted.
8. Inside seals compress when slide-out is extended.
9. Slide-out extends and retracts smoothly.
10. Both sides of slide-out are synchronized.
11. Any dirt or debris is cleaned from the interior or exterior of the unit.

It is recommended that when operating in harsh environments (road salt, ice build up, etc) the moving parts be kept clean. They can be washed with mild soap and water. No grease or lubrication is necessary and in some situations may be detrimental to the environment and long term dependability of the system.

Electrical System Maintenance

For optimum performance, the slide-out system requires full battery current and voltage. The battery **MUST** be maintained at full capacity. Other than good battery maintenance, check the terminals and other connections at the battery, the control switch, and the system for corrosion, and loose or damaged terminals. Check motor leads under the trailer chassis. Since these connections are subject to damage from road debris, be sure they are in good condition.

NOTE: The Lippert Slide-out System is designed to operate as a negative ground system. A negative ground system utilizes the chassis frame as a ground and an independent ground wire back to battery is necessary. It is important that the electrical components have good wire to chassis contact. To ensure the best possible ground, a star washer should be used. Over 90% of unit electrical problems are due to bad ground connections.

Mechanical Maintenance

Although the system is designed to be almost maintenance free, actuate the room once or twice a month to keep the seals and internal moving parts lubricated. Check for any visible signs of external damage after and before movement of the unit.

NOTE: For long-term storage, it is recommended that the room be closed (retracted).

Troubleshooting

Troubleshooting Introduction

This troubleshooting chart outlines some common problems, their causes and possible corrective actions. If any part or serial number information is available, provide it to the service technician when asking for assistance. The Lippert Slide-Out System is only one of four interrelated slide-out room system components. These four components are: chassis, room, unit, and Lippert Slide-Out System. Each one needs to function correctly with the others or misalignment problems will occur.

Every unit has its own personality and what may work to fix one trailer may not work on another even if the symptoms appear to be the same.

When something restricts room travel, system performance will be unpredictable. It is very important that slide tubes be free of contamination and allowed to travel full distance (Stroke). Ice or mud buildup during travel is an example of some types of contamination that can occur.

When you begin to troubleshoot the system, make sure the battery is fully charged, there are no visible signs of external damage to the system and that all connections are secure.

During troubleshooting, remember that if you change something, that change may affect something else. Be sure any changes you make will not create a new problem.

You can obtain additional information on the Lippert Slide-Out System by visiting customerservice@lci1.com or by calling 432-LIPPERT (432-547-7378)

What Is Happening?	Why?	What Should Be Done?
Room doesn't move when switch is pressed.	Restriction or obstruction inside or outside of unit.	Check for and clear obstruction.
	Low battery voltage, blown fuse, defective wiring.	Check battery voltage and charge if needed. Find and check fuse, replace if blown. Check battery terminals and wiring. Look for loose, disconnected or corroded connectors.
Actuator motor runs but room does not move.	Actuator not attached to front mounting drive bracket.	Check jam nuts/Nylock nuts. Be sure that they are properly tightened and adjusted.
	Bad motor or gear housing.	Replace motor.
Motor runs but room moves slowly.	Low battery voltage, poor ground, extremely low outdoor temperature.	Charge battery and check ground wire.
	Room is in a bind.	Check to see that room is properly adjusted.
Room stalls in mid travel.	Actuator in a bind.	Crank manual override and move room short distance then retry electric switch to move room.
	Bad actuator.	Replace actuator if above instructions do not work.

Comparing 14.5° and 20° Rack and Pinion Gears

1. Start by measuring the distance between two individual adjacent teeth.
2. Using calipers or a steel rule, measure from the inside edge of one tooth (A), and then measure over to the inside edge of the next tooth (B) shown in (Fig. 2).
3. The 14.5° rack will measure approximately 0.170 inches (Fig. 3). The 20° rack will measure approximately 0.231 inches (Fig. 4).
4. The 14.5° rack will have 4 teeth per inch (Fig. 5). The 20° rack will have 3 teeth per inch (Fig. 6).

Fig. 2 - Side View

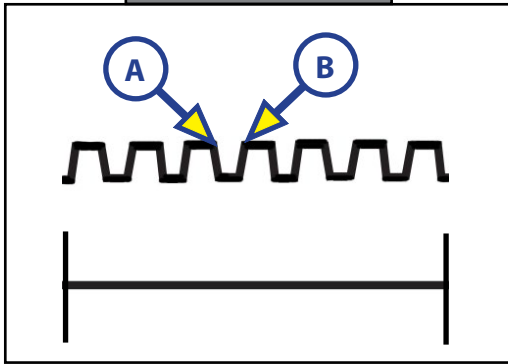

Fig. 3 - 14.5° Rack



Fig. 4 - 20° Rack

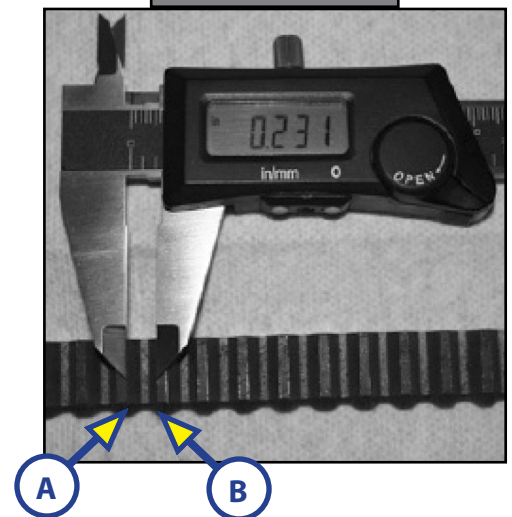

Fig. 5 - 14.5° Rack

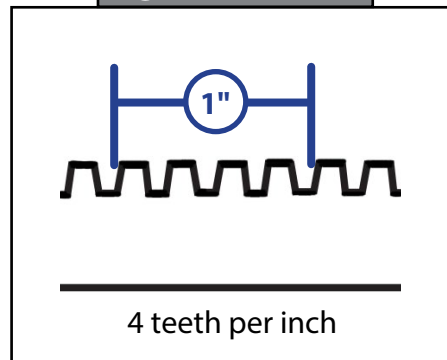
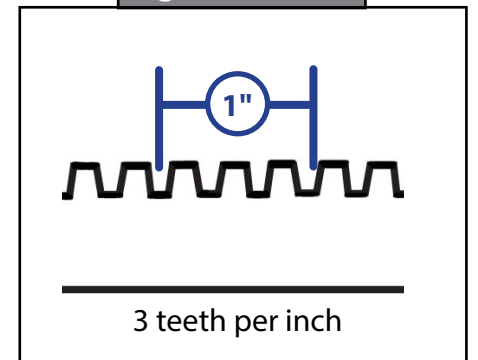

Fig. 6 - 20° Rack



Spur Gear Comparison

The simplest way to differentiate between the 14.5° spur gear and the 20° spur gear is the number of teeth on the gear. Spur gear [#122739](#) (Fig. 7) has 18 teeth. Spur gear [#101941](#) (Fig. 8) has 15 teeth.

Fig. 7

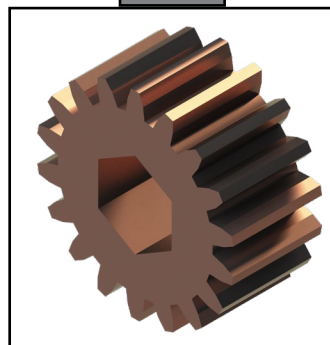
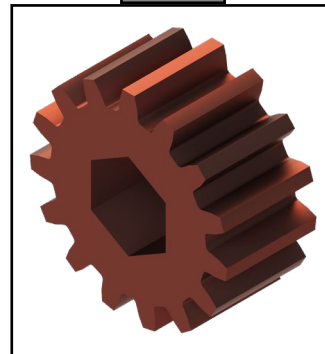

Fig. 8



Gear Pack Replacement Instructions

In the event a gear pack needs to be replaced, follow these steps:

1. Run slide-out room half way out.
2. Place a jack under the inner arm of the slide-out.
3. Jack room up just enough to remove pressure off the gear pack.
4. Remove drive bolt from the cross shaft.
5. Remove bolts which hold the gear pack assembly in place on the outer rail (Fig. 9).
6. Drop out the damaged gear pack.
7. Install the new gear pack.
8. Install bolts to hold gear pack assembly in place on the outer rail.
9. Install cross shaft and bolt.
10. Gear pack assembly does not need to be torqued down, only adequately and securely tightened.

Gear Packs	
281331	2 x 2
140409	2 x 3, 3 x 3
324869	Standard 2.5 x 2.5
123356	Heavy Duty 2.5 x 2.5
140418	Embedded Rack

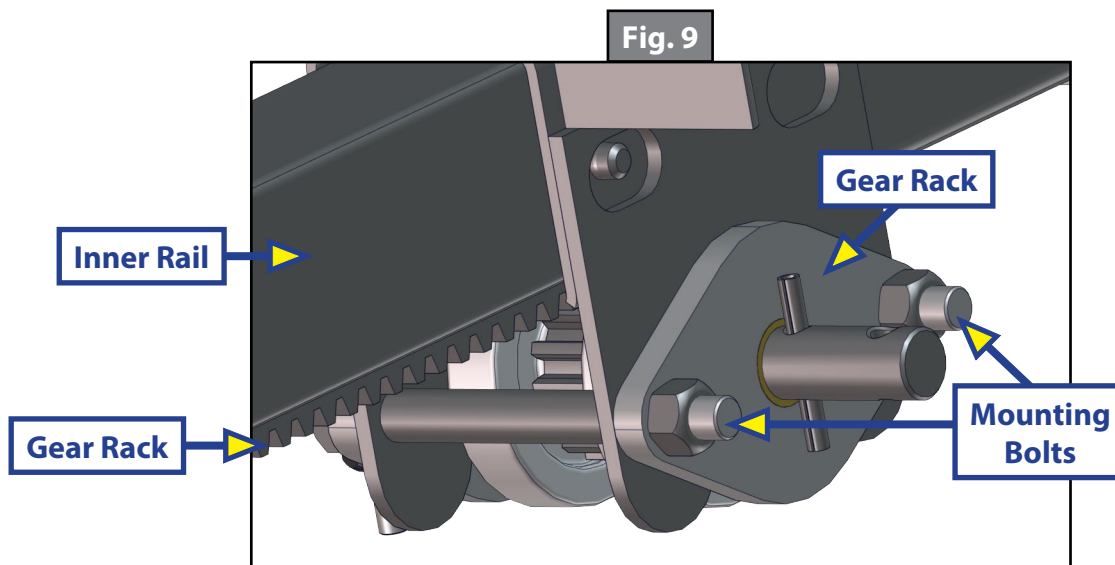

Corrective Action for Squeaking Gear Packs

1. Loosen both gear packs bolts (Fig. 10A and Fig. 10B) until tension is off of the gear pack.
2. Apply dry silicone onto the gear pack drive shaft at lubrication points (Fig. 11A), (Fig. 12A), (Fig. 13A through D).

NOTE: Do not lubricate rack or pinion gear teeth, lubricate drive shaft only.

3. Extend and retract slide-out arms several times to work lubricant through gear pack.

Fig. 10



A

B

Fig. 11

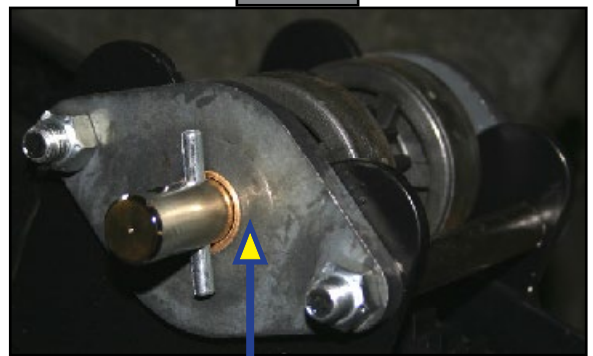

A

Fig. 12

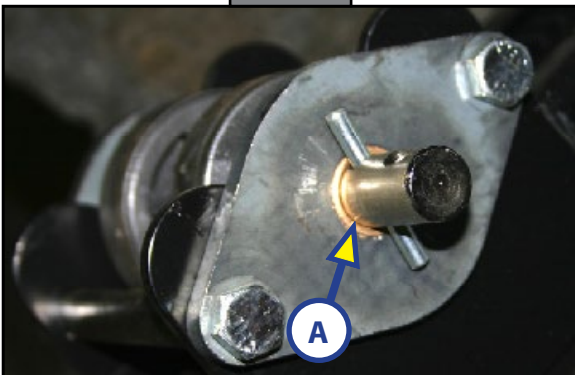

A

Fig. 13

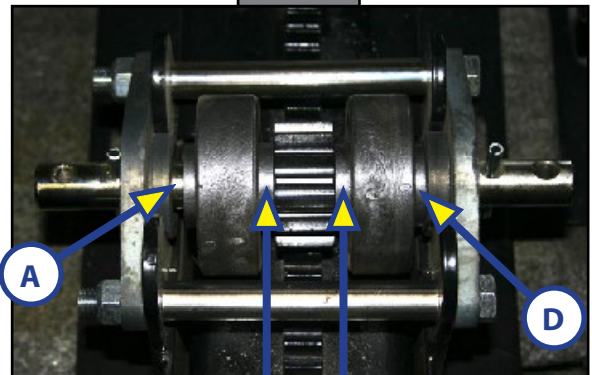

A

B

C

D

Removing and Replacing Actuator (Fig. 14)

1. Disconnect manual crank shaft (A) from end of motor assembly.
2. Disconnect motor wires from source (B).
3. Take measurements (G) and (H) from the end of the threaded rod. The stop can and jam nuts will be replaced using those measurements.
4. Remove all jam nuts (F) and stop can (E) from threaded shaft on actuator.
5. Take note of mounting bolt locations and remove mounting bolts (D) from hat channel (C).
6. After everything is disconnected, slide actuator out of frame. To replace with new actuator, follow previous directions in reverse.

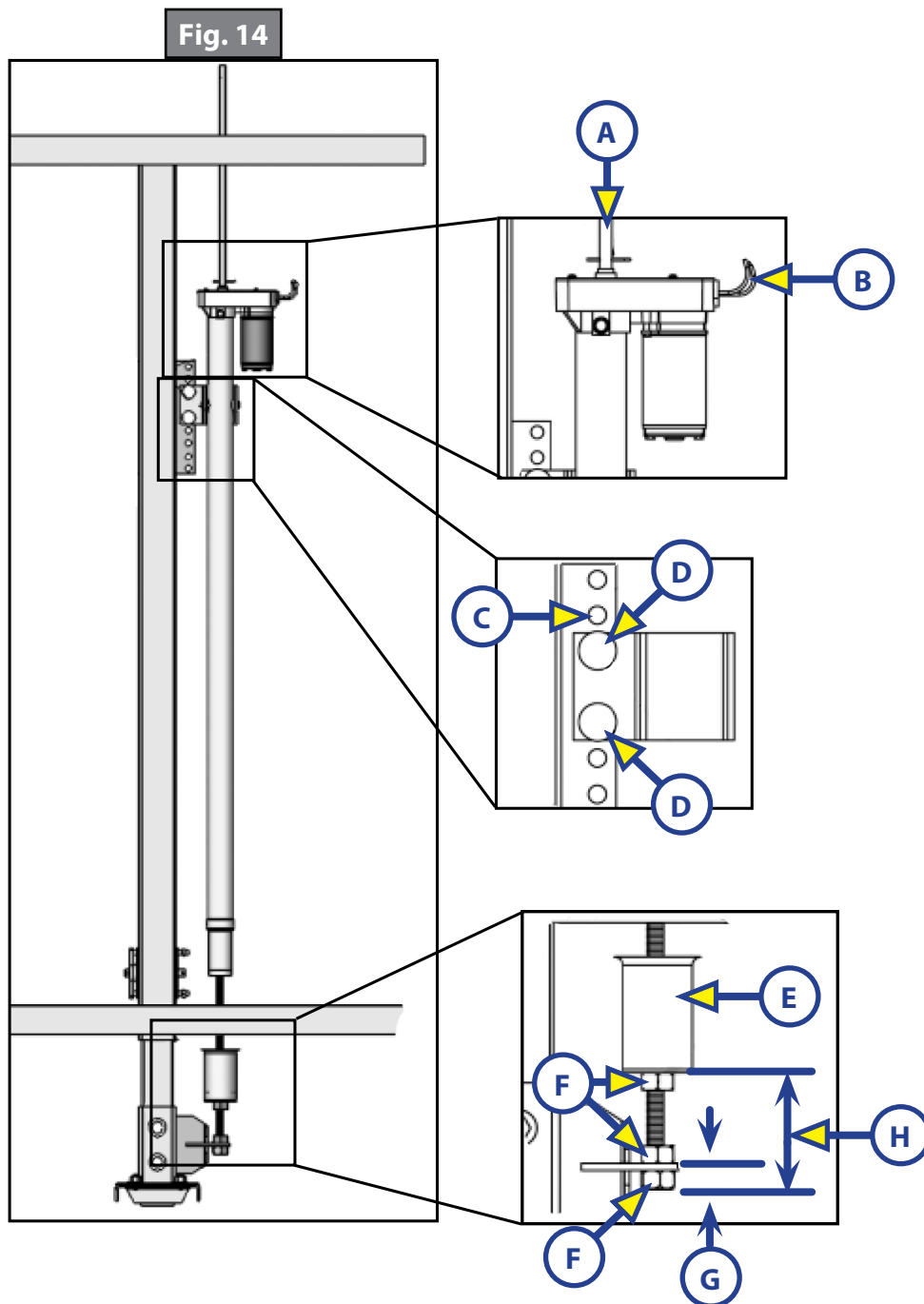

Motor Troubleshooting

Before attempting to troubleshoot the motor, make sure an adequate power source is available. The unit batteries should be fully charged or the unit should be plugged into A/C service with batteries installed. Do not attempt to troubleshoot the motor without assuring a full 12V DC charge.

The following tests require only a DC voltmeter (or DC test light) and a jumper lead.

1. Attach voltmeter (or test light) leads to the negative and positive switch terminals on back of wall switch. Does the meter indicate 12V DC? If **YES**, see **Step 2**; if **NO** see **Step 3**.
2. If **YES**, at the motor, check the incoming leads to 12V DC (if necessary, disconnect leads at wire splices). Does meter indicate 12V DC? If **YES**, motor needs to be replaced. The motor is not field serviceable. **DO NOT ATTEMPT TO REPAIR**. If **NO**, inspect all wires and connections between the wall switch and the motor. Repair connections as necessary. Recheck as in **Step 1**.
3. If **NO**, inspect all connections between battery and switch. Inspect 30A Auto-reset Circuit Breaker (See Next Page). Recheck as above in **Step 1**.
4. Since there are no field serviceable parts in the motor, electrical troubleshooting and service is limited to replacing only those components as previously outlined.
5. Thorough inspection of wiring and connections is the only other electrical service that can be performed.

Fig. 15 - Old Slide-Out Switch Color Codes

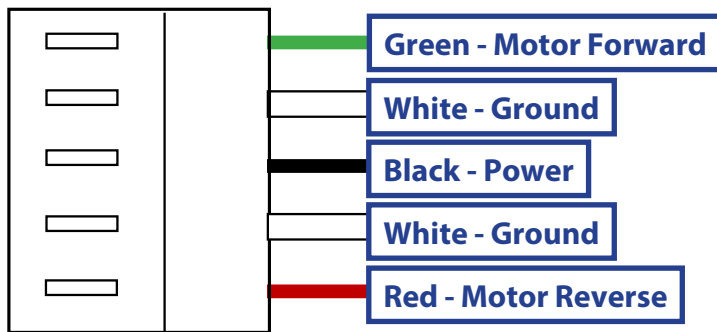
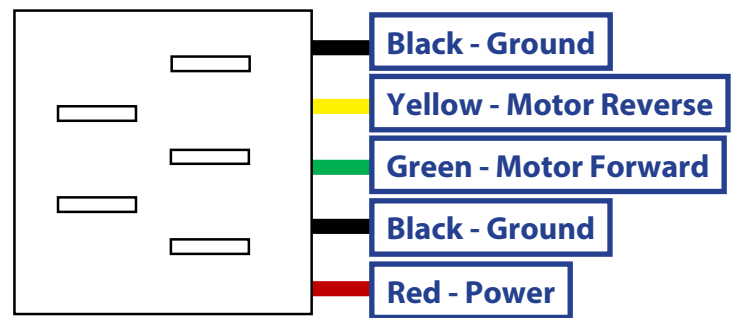
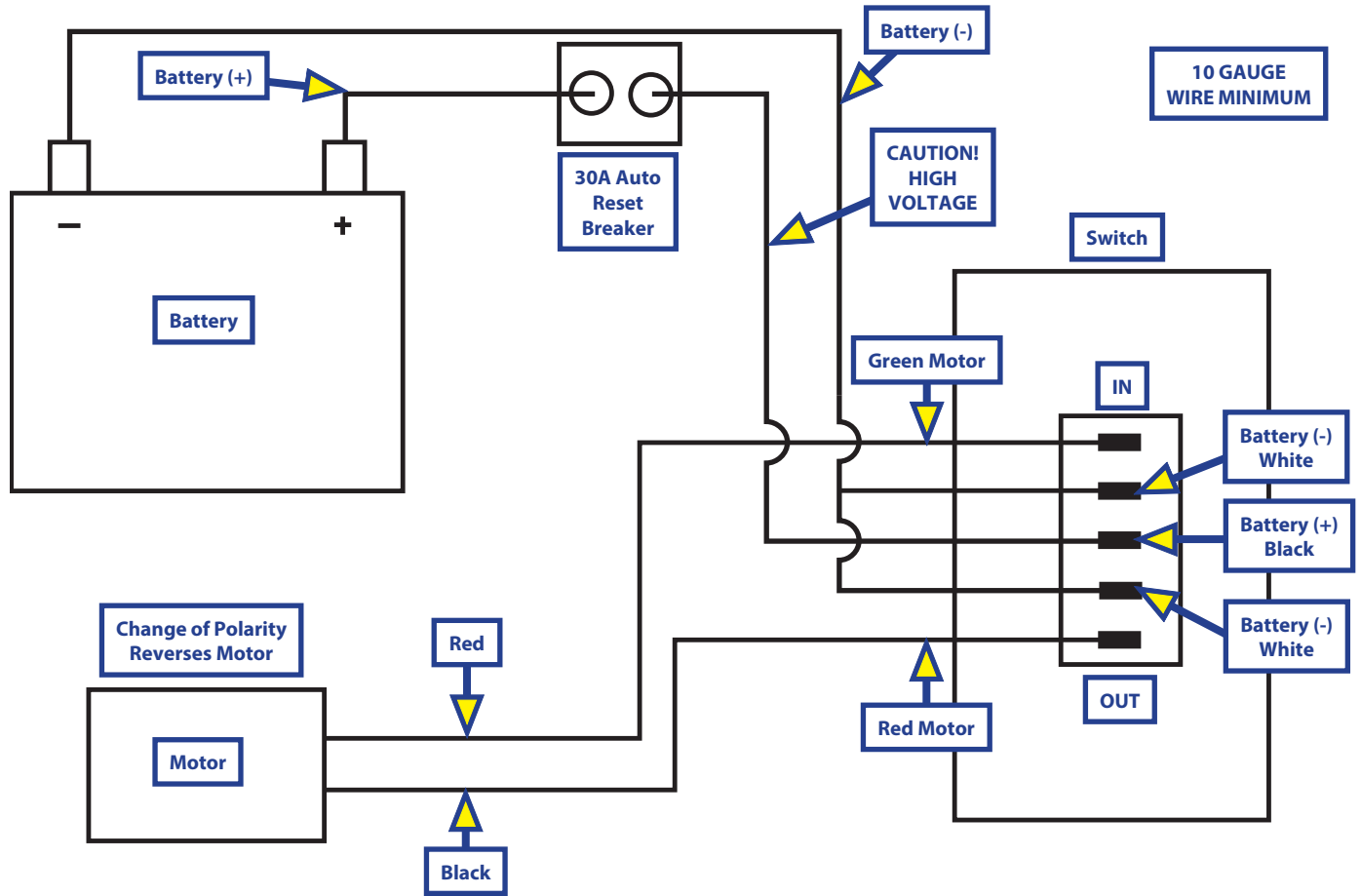

Fig. 16 - New Slide-Out Switch Color Codes



Old Slide-Out Switch Wiring Diagram



New Slide-Out Switch Wiring Diagram

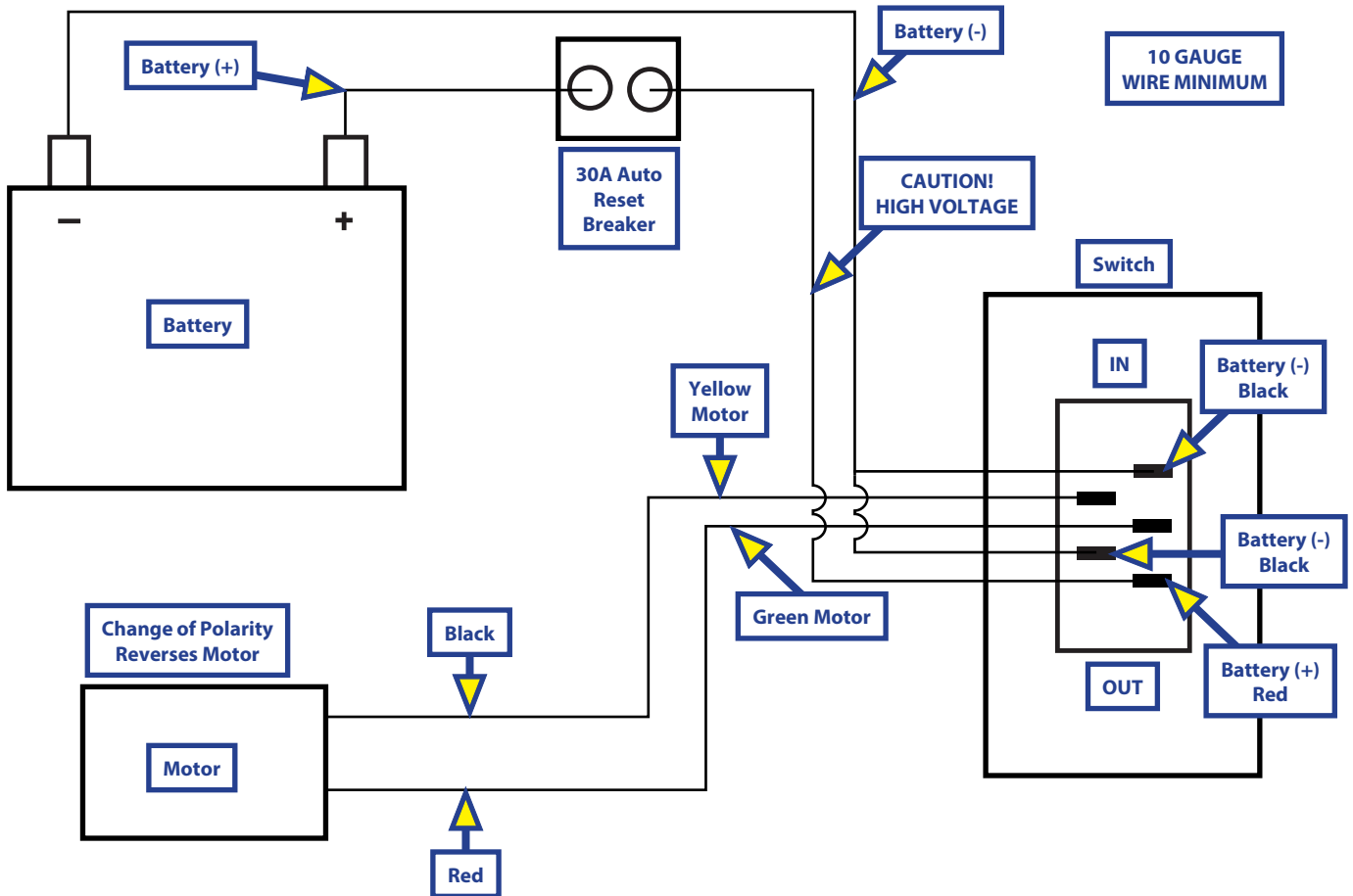

Room Bar Measurement Chart

Instructions

1. Circle which side of your unit this room bar is for (Door Side or Off Door Side).
2. Enter the measurements for A, B, C, and D on the lines at the bottom.

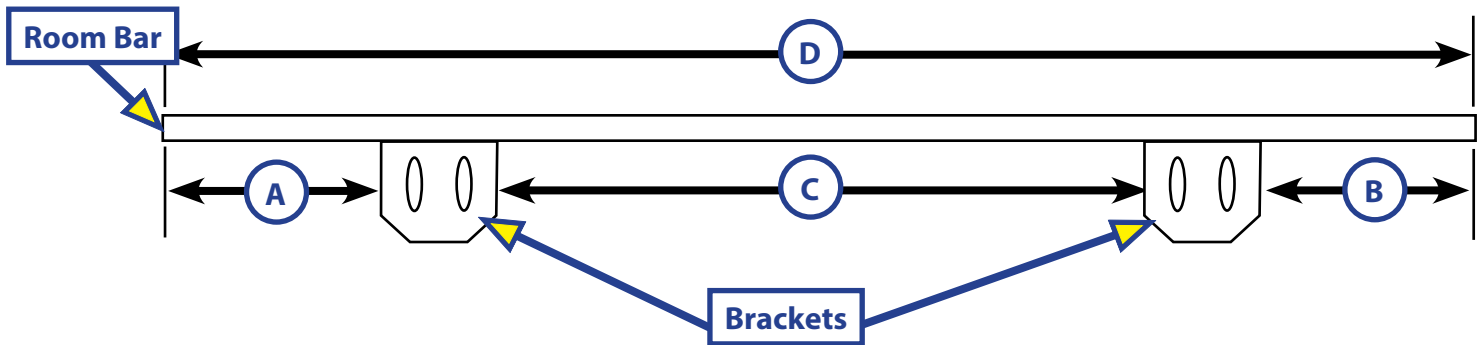
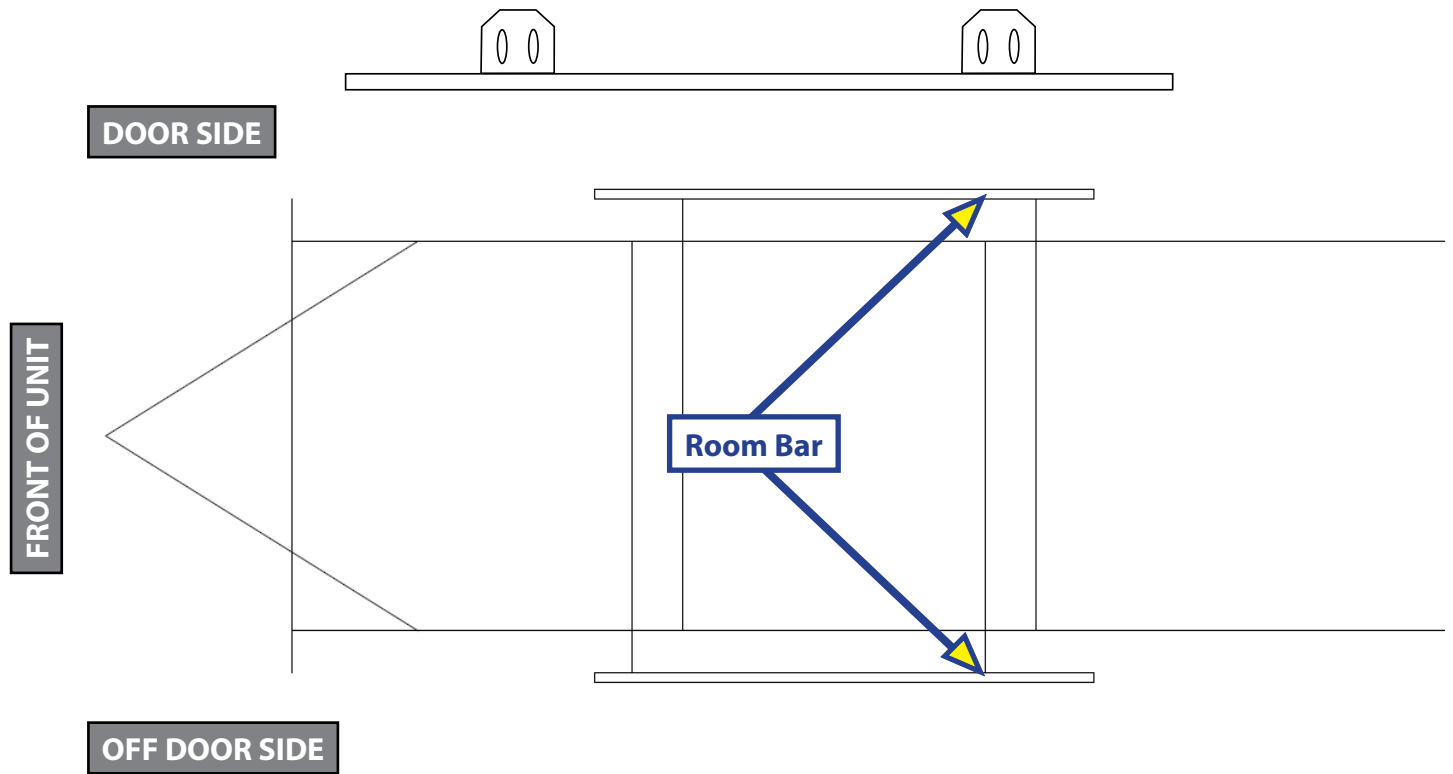

A _____ B _____ C _____ D _____

Mechanical Room Adjustment

NOTE: All slide-out room adjustments **MUST** be performed by certified service technicians. Adjustments made by non-certified persons may void any and all warranty claims.

Horizontal Adjustment

1. Loosen 2 carriage bolts "A" on each bracket located at the end of each guide tube (Fig. 17).
2. Room is ready to be positioned horizontally by pushing on the outside, sidewall or by using a prying device inserted into the opening between the room and unit.

NOTE: Use caution when using prying device so seals do not become damaged.

Vertical Adjustment

3. Loosen 2 carriage bolts "A" on each bracket located at the end of each guide tube (Fig. 17).
4. Loosen jam nut (Fig. 18).
5. For vertical adjustment turn vertical adjustment bolt "B" up or down to locate room height (Fig. 18).
6. Once room is located, tighten carriage bolts "A" and jam nut bolts (Figs. 17 and 18).

Fig. 17

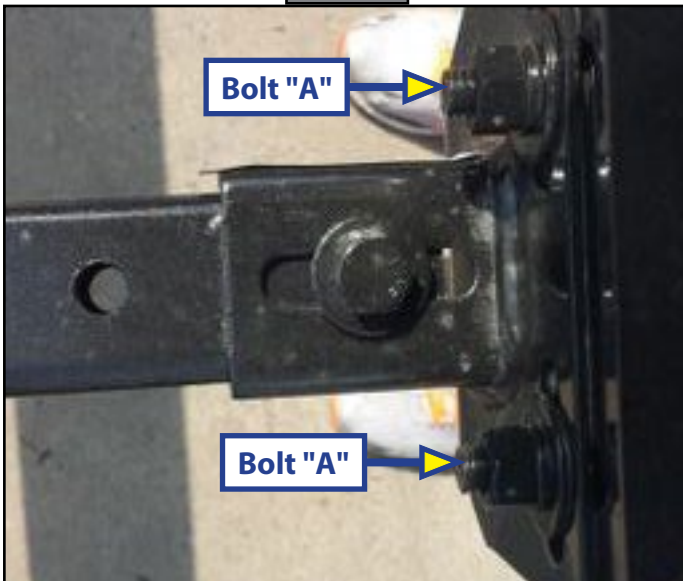
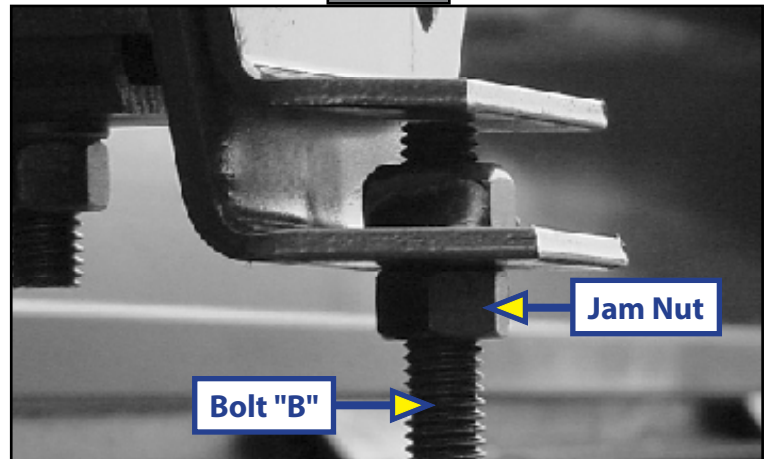

Fig. 18



Adjusting room so it seals in the IN position

1. Locate the actuator coming through the frame.
2. On the end of the actuator, there is a threaded shaft mounted to the drive bracket with three nuts and a stop can (Fig. 19).
3. Loosen the $\frac{3}{4}$ " nut (Fig. 19A) on the outside of the stop can using a $1\frac{1}{8}$ " wrench.
4. Screw the can in or out, and then tighten down the nut - doing so will change the location of the seal going to the "in" position.

Adjusting room so it seals in the OUT position

1. Locate the actuator coming through the frame.
2. On the end of the actuator, there is a threaded shaft mounted to the bracket with three nuts and a stop can (Fig. 19).
3. Using a $1\frac{1}{8}$ " wrench, move the $\frac{3}{4}$ " nut (Fig. 19B) and, using a $1\frac{1}{16}$ " wrench, move the Nylock nut (Fig. 19C) in either direction. This will change the location of your seal going to the "out" position.
4. Make sure all nuts are tight.

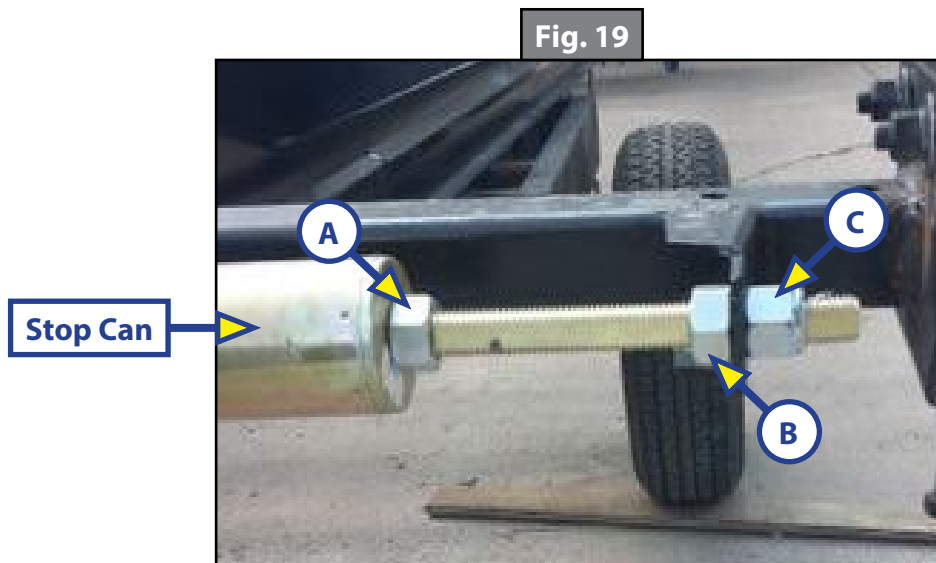

Manual Override

NOTE: Always disconnect battery from system prior to manually operating system. Failure to disconnect battery can cause electricity to backfeed through the motor and cause serious damage to the system as well as void the warranty.

The Lippert Electric Through Frame Slide-out comes with a Manual Override system. There are two different methods for manually extending and retracting the slide-out room. A crank handle extension or 3/4" socket and ratchet can be used outside the chassis main rail at the crank extension with pin (Fig. 20-21). A socket and ratchet can be used inside the main frame on the hex head crank extension (Fig. 22-23).

Manual Override - Outside Frame

Locate the crank extension with pin outside of the chassis main rail (Fig. 20). This is where the crank handle fits on (Fig. 21) to allow the manual extension/retraction of the room. Rotate the crank handle clockwise to retract and counterclockwise to extend slide-out. It is important to note that you DO NOT need to attempt to disengage the motor as the actuator is "manual ready." Just hook up and crank.

NOTE: Use EXTREME CAUTION when extending and/or retracting room using the manual override feature. It is possible to operate the slide-out beyond the maximum extension and/or retraction and damage the slide components, slide room structure or trim components.

NOTE: The gears can be stripped out if the room is manually retracted/extended to its fullest extent and the operator continues to rotate manual override. Any damage due to misuse of the Manual Override feature will disqualify any and all claims to the Limited Warranty.

Fig. 20

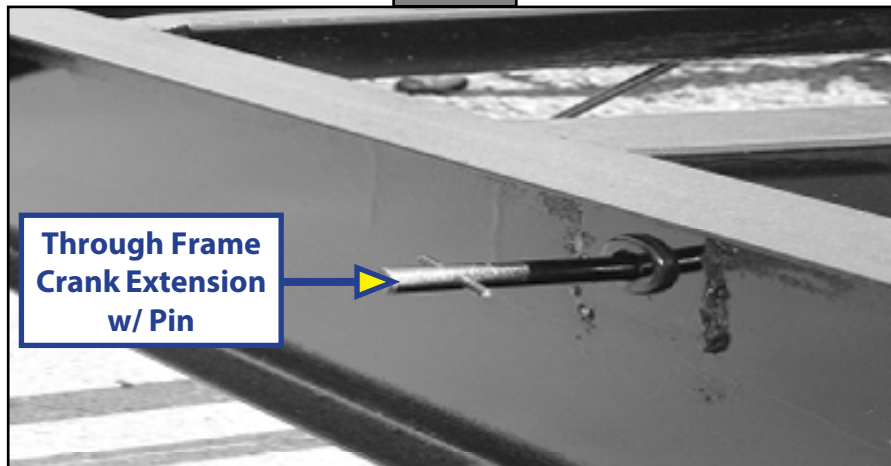
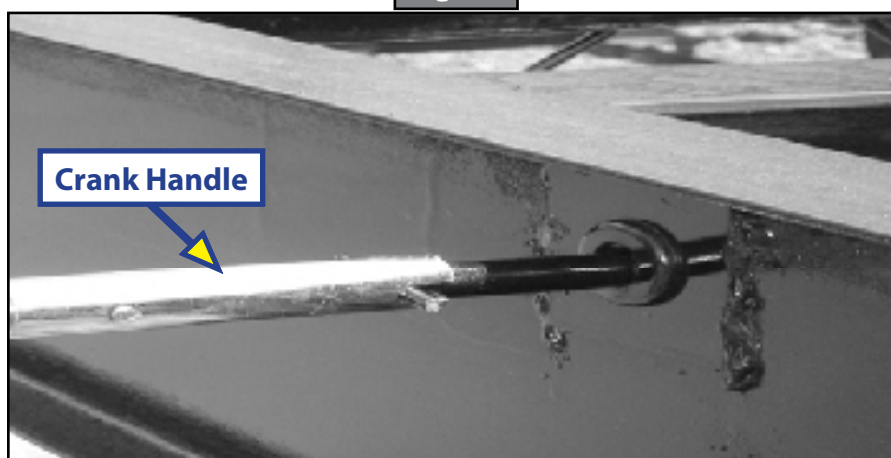

Fig. 21



Manual Override - Inside Frame

Locate the hex head crank extension at the top of the actuator inside the chassis main frame (Fig. 22). Using a $\frac{3}{4}$ socket and ratchet (Fig. 23), rotate the extension clockwise to retract the slide-out and counter clockwise to extend the slide-out. It is important to note that you DO NOT need to attempt to disengage the motor as the actuator is "manual ready."

NOTE: Use EXTREME CAUTION when extending and/or retracting room using the manual override feature. It is possible to operate the slide-out beyond the maximum extension and/or retraction and damage the slide components, slide room structure or trim components.

NOTE: The gears can be stripped out if the room is manually retracted/extended to its fullest extent and the operator continues to rotate manual override. Any damage due to misuse of the Manual Override feature will disqualify any and all claims to the Limited Warranty.

Fig. 22

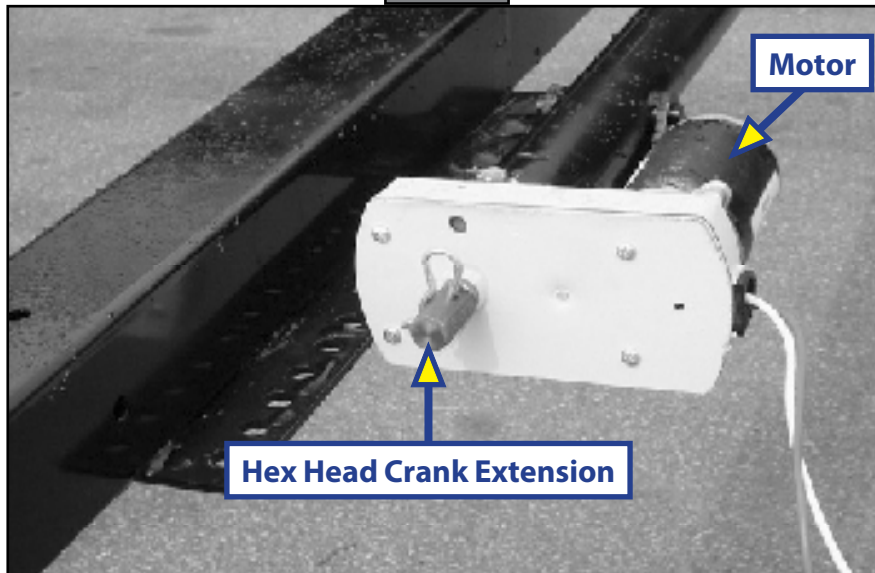
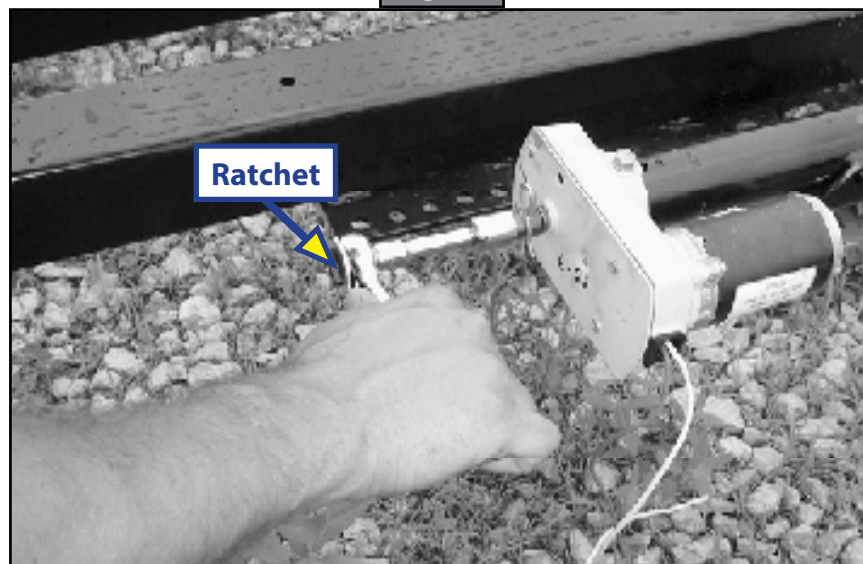

Fig. 23





The contents of this manual are proprietary and copyright protected by Lippert. Lippert prohibits the copying or dissemination of portions of this manual unless prior written consent from an authorized Lippert representative has been provided. Any unauthorized use shall void any applicable warranty. The information contained in this manual is subject to change without notice and at the sole discretion of Lippert. Revised editions are available for free download from lippert.com.

Please recycle all obsolete materials.

For all concerns or questions, please contact Lippert
Ph: 432-LIPPERT (432-547-7378) | Web: lippert.com | Email: customerservice@lci1.com