



**ELECTRIC MOTOR DRIVEN  
SLIDE-OUT  
O.E.M. INSTALLATION  
MANUAL**

81-1291  
REV. 2

**Slide out systems must be engineered carefully to provide good performance. Changes to weight, stroke, weight distribution, rail position, controller, power supply, seals, slide toppers, ramps, rollers, etc. all have an affect on the performance of the system. In order to secure warranty coverage, each new application or changes to existing applications must be audited and approved by Lippert Components Engineering with a signed document. Audits can be arranged by calling 574-537-8900 and asking for your account representative.**

### **Slideout room general requirements**

- Power and wiring must be such that there are **not less than 10.5 running volts** supplied at the motor leads under maximum load.
- Maximum motor amp draws of 15 Amps running and/or 20 Amps up ramp. Systems with amps draw higher than specified must be approved in writing.
- Slide system controls must come from Power Gear. Controls supplied by other companies may void warranty.
- Voltage supply must come from a 12VDC automotive/RV type battery.
- Rails-3x3, 3x2, 2x2 rail profiles are able to support 400 lb. at 32" of stroke (Max.). Systems with room weights higher or room extensions longer than specified must be approved in writing.
- Single rail systems must have rails centered to properly support room slide out.
- Multi rail systems must have the weight and mass of the room divided equally over the rails i.e. two rail systems would have the rails mounted 20% - 30% of room width in from both ends of the room.

# Installation Instructions for Power Gear Electric Slide-Out System

## Single Rail Slide-Out System

1. Ensure clearance for the motor.
2. For units with rails welded into the frame-burn-out mounting holes for the outer rail into the chassis frame rails at the locations determined by your Engineering Dept..
3. Position and weld the outer rail into the chassis frame at the location determined by your Engineering Dept.. Depending on the frame construction support plates are provided to be used as covers for the mounting holes burned into the frame rails and can be positioned on the inside or outside of the rail. **NOTE:** Ensure that the systems rails are perpendicular to the frame rails.

## Double Rail Slide-Out System

1. Determine the slide-out rail span width. Ensure clearance for the motor, drive shaft, and manual override.
2. Burn-out mounting holes for the outer rails into the chassis frame rails at the locations determined by your Engineering Dept..
3. Position and weld the outer rails into the chassis frame at the location determined by your Engineering Dept.. Depending on the frame construction support plates are provided to be used as covers for the mounting holes burned into the frame rails and can be positioned on the inside or outside of the rail.

## Outer Rail Installations

- Outer rails must be square to the chassis frame and parallel to each other within 1/8" and within 1/4" from corner to corner (**refer to dimensional drawing**; failure to weld outer rails square and parallel will cause inner rails to bind or will prevent room from sealing properly).
- Centerline of drive shaft must be a **minimum** of 3.5" from the inner frame rail web. If an override gearbox is used, this dimension **must** be set at 3.5"

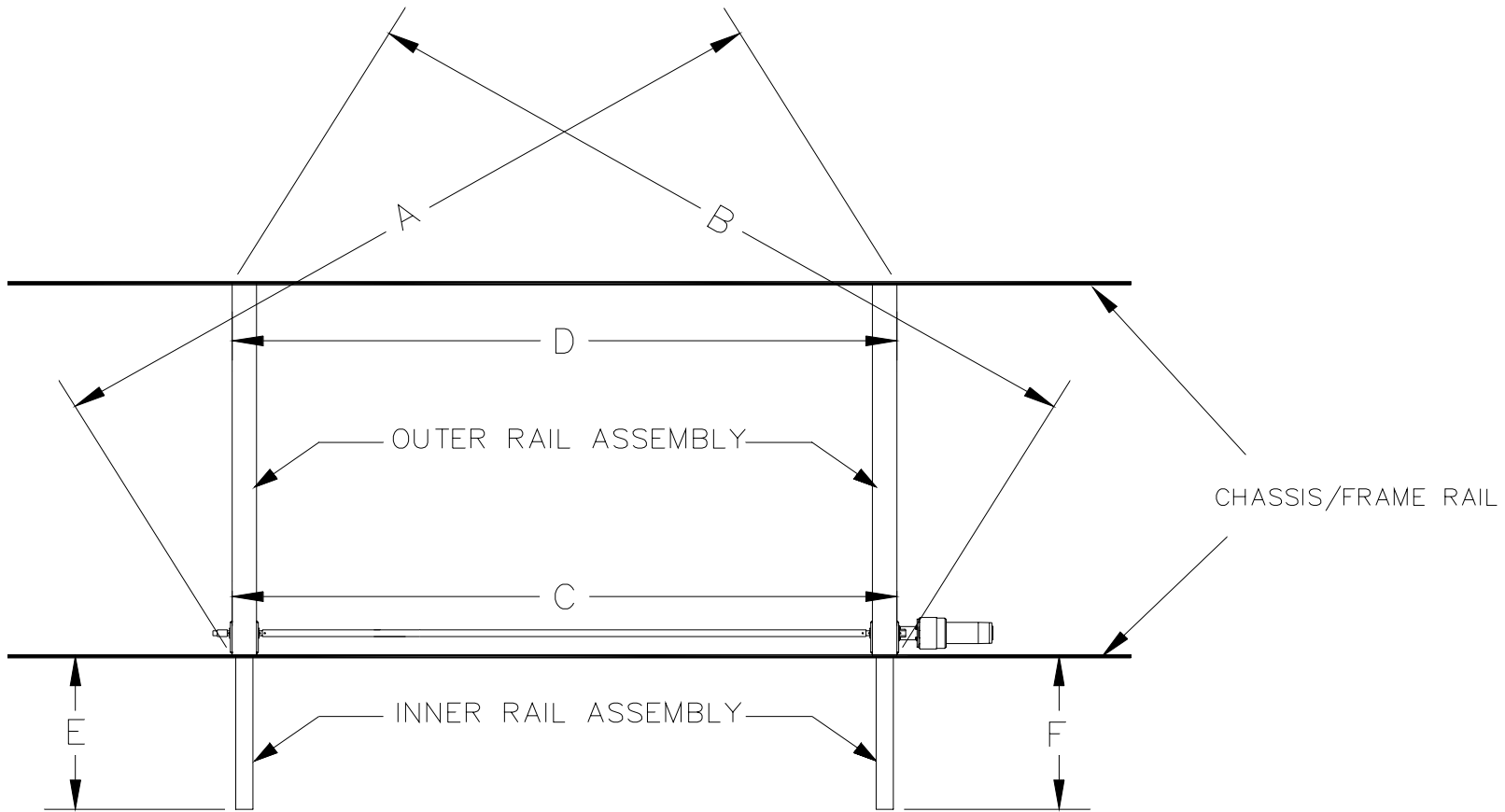

DOUBLE RAIL SLIDEOUT SYSTEM

"A" AND "B" TO HAVE 1/4" MAX. VARIATION  
 "C" AND "D" TO HAVE 1/8" MAX. VARIATION  
 "E" AND "F" TO HAVE 1/8" MAX. VARIATION

# **Assembly of Components**

Power Gear Slide-Out comes with some pre-assembly. The drive shaft, outer rails and inner rails may come pre-assembled.

## **Single Rail Slide-Out Systems**

1. Insert inner rail into the outer rail until the gear rack on the inner rail engages the spur gear in the outer rail. Set the inner rail at a desired position.
2. Units with inner rail adjustment wedges will have the adjustment wedges inserted and cut off at this point.
3. Room to slide-out system attachment brackets should be done with room and rails extended approx. 24" or greater from side walls.
4. Make the proper slide system adjustments. Start by setting the room height so the distance between the bottom of the room floor and the top of the inner rail is the same distance from the front edge of the room back to the rear of the room; failure to maintain this distance will pinch the rails as the room is retracted, causing the room to bind and not fully retract. See room height adjustment notes.

## **Double Rail Slide-Out System**

1. Assemble the drive shaft to the outer rail gear assembly shafts using the supplied 1/4" bolts, washers, and nylock nuts. These are specially designed bolts and nuts. Hardware supplied by anyone other than Power Gear cannot be used. If using the manual override gearbox option, assemble the gearbox onto the 1" drive shaft before installation of the bolts, then secure the override gearbox to frame rail.

## Torque Specification for Slide Out Drive shaft Bolts

The proper torque value of the drive shaft bolts is **168 in-lbs.** Refer to figures below for proper assembly of the drive shaft hardware.

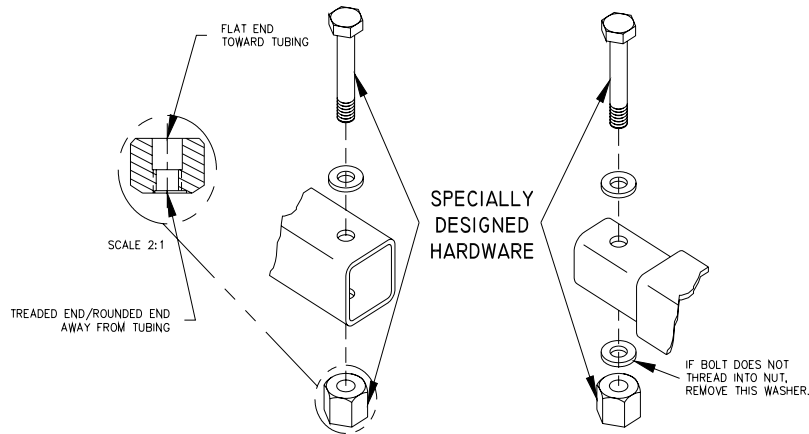

**Fig. #1**  
**1" Square Tubing End**  
**(Drive End)**

**Fig. #2**  
**13/16" Square Tubing End**  
**(Idler End)**

2. Insert both inner rails into the outer rails until gear rack on inner rails just touches the spur gear in the outer rails. Push both inner rails in simultaneously engaging the gear rack with the spur gear. This should align the inner rails. To verify the alignment of the inner rails, measure from the chassis frame rail to the end of the inner rail. Both rails should be the same distance (+/-1/16"). If the inner rails vary more than the 1/16", refer to the section on inner rail "Timing".
3. Units with inner rail adjustment wedges will have the adjustment wedges inserted and cut off at this point.
4. Room to slide-out system attachment brackets should be done with room and rails extended approx. 24" or greater from side walls.
5. Make the proper slide system adjustments. Start by setting the room height so the distance between the bottom of the room floor and the top of the inner rail is the same distance from the front edge of the room back to the rear of the room; failure to maintain this distance will pinch the rails as the room is retracted, causing the room to bind and not fully retract. See room height adjustment notes.

## FLAT FLOOR ROOM HEIGHT ADJUSTMENT

Information on **setting the room height on a flat floor slide-out system utilizing angled rails.**

With the room fully extended-

- Measure from the top of the moving slide-out rail to the bottom of the slide-out room floor up close to the coach. This is dimension "A".
- Measure from the top of the moving slide-out rail to the bottom of the slide-out room floor out near the mounting bracket. This is dimension "B".
- To calculate dimension "B" use the following formula:  
"B" (end bracket height setting) = "A" + (slideout room floor thickness) +  $\frac{1}{4}$ ".

EXAMPLE:

**"B" (end bracket height setting) = "A" + (slideout room floor thickness) +  $\frac{1}{4}$ ".**

**If "A" = 3-1/4"**

**Then "B" = 3-1/4" + 1" +  $\frac{1}{4}$ " = 4-1/2"**

- Perform this check on each slide-out rail independent of the other.

### **NOTE:**

- 1) These figures are approximates. Each coach may be slightly different.
- 2) Refer to manufacturer of coach/trailer for correct slideout room floor thickness.

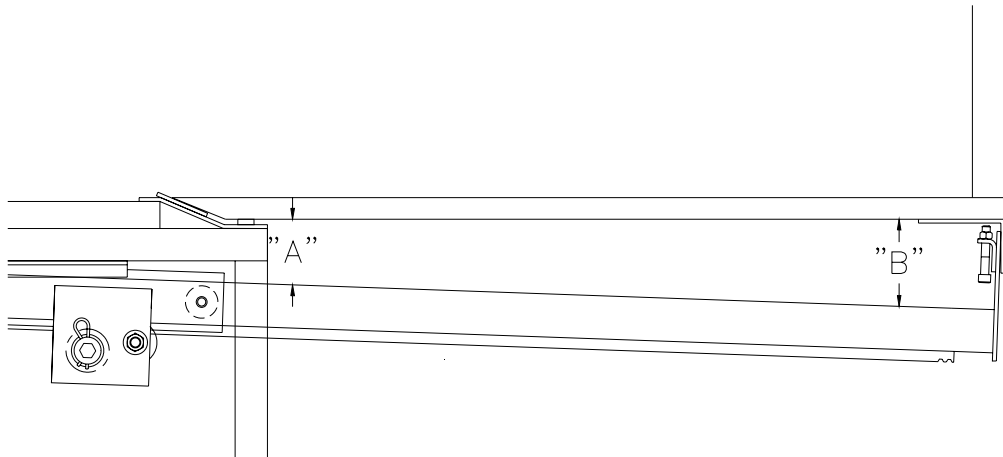

# NON FLAT FLOOR SLIDE-OUT ROOM HEIGHT ADJUSTMENT

For proper slide-out operation the slide-out room floor to slide-out rail height must be set. This procedure is to be performed at the factory during room installation and should be checked periodically.

To set the room height, please refer to the Figure below.

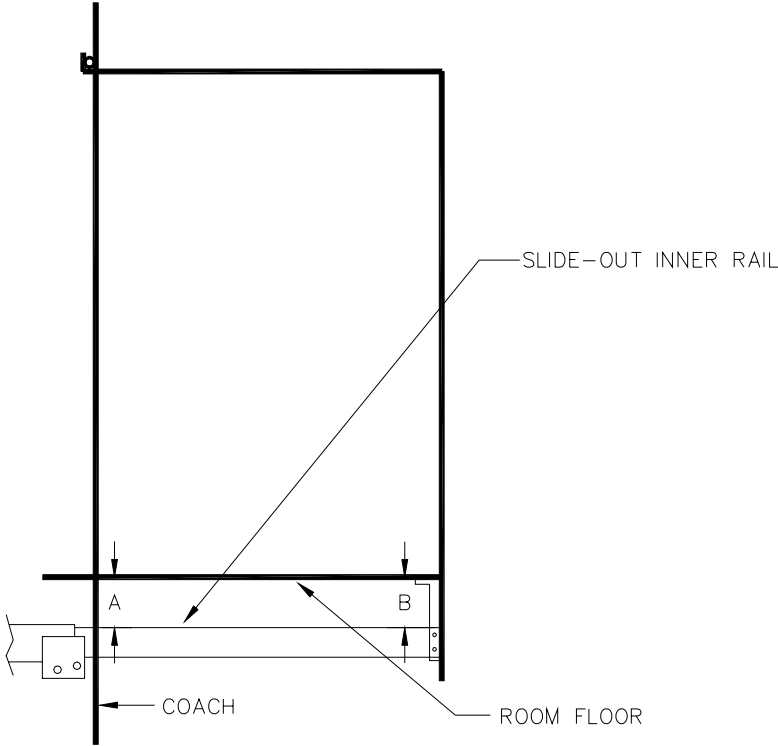

$$B = A + \frac{1}{8}''$$
$$-0''$$

The distance between the bottom of the floor and the top of the inner rail must be the same distance (A=B) or the distance at the end of the inner rail can be 1/8" greater than the inside distance (B=A+1/8").



## Rail "Timing"

End of inner rails must extend from chassis frame the same distance  $\pm 1/16"$ . If the inner rails vary more than the  $1/16"$ , refer to the instructions on inner rail realignment. There are several methods of setting the timing between rails. One of the more popular methods is illustrated here. **NOTE:** Failure to set inner rails at proper distance will prevent room from sealing properly.

### Inner Rail Alignment

1. Remove cotter hairpin from idler drive shaft.
2. Push the idler drive shaft toward inner rail to disengage the gear from the gear rack.
3. Adjust the room by sliding the idler rail side of the room to the proper position (same distance from the frame as the drive rail side).
4. Push the idler drive shaft back into position engaging the gear and the gear rack.
5. Reinstall cotter hairpin in idler drive shaft.
6. Extend and retract room a couple of times and check for proper room flange sealing.
7. If room is not aligned properly, repeat steps 1 thru 6.

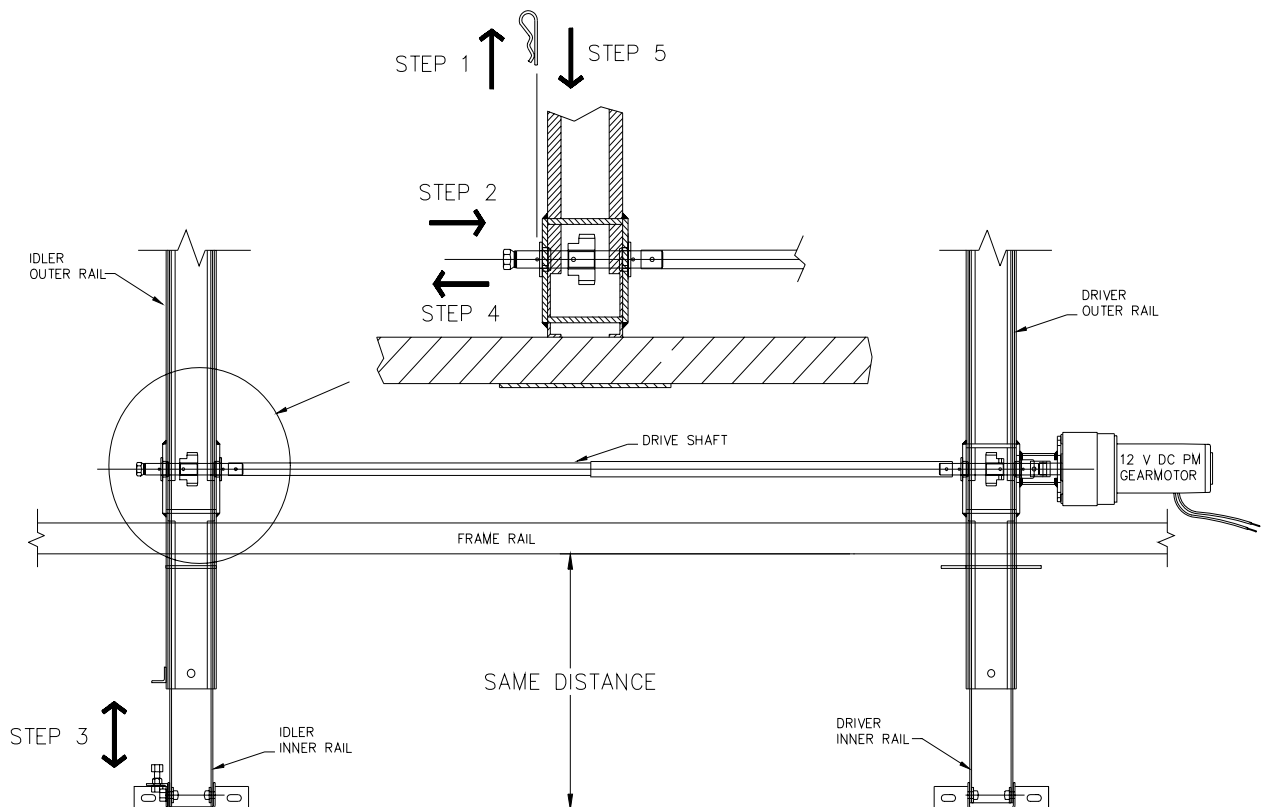

## Rail in and out stops

If the slide-out is supplied with room movement stops, adjust the stop bolt at this time to provide adequate sealing of the slide-out room.

## Motor Installation

- Torque motor mounting bolts to 40 in-lbs. Make sure motor drive pin is fully engaged into shaft coupling slot before tightening. Assemble the gear motor to the motor mounting plate using the supplied (4) 5/16" bolts and lock washers.
- **NOTE:** Make sure that the motor shaft drive pin mates with the coupling groove on the gear shaft.
- Ensure motor brake override lever is "engaged" (lever in 6 o'clock position) before frame leaves work station; failure to engage motor brake will result in 'creepage' of room after power is shut off to the motor.

## Wiring and Protection

- Power and wiring must be such that there are **not less than 10.5 running volts** supplied at the motor leads under maximum load.
- The system must use controller supplied by Power Gear. Several different types are available to suit different needs. Slide out system controllers are a necessary item to provide low voltage loss, and proper brake operation.
- **NOTE:** Use of other protective devices not approved by Power Gear in writing may void warranty.
- Slide-Out system wiring **must** be 10 gauge wire minimum, and on longer runs, 8 gauge may be required. Refer to RVIA electrical standards in ANSI A119.2 for wire length, fusing, and sizing. The following chart is for reference only but gives an approximate maximum length:

	Spur Gear Motor	Worm Gear Motor
10 AWG	35 ft.	20 ft.
8 AWG	55 ft.	30 ft.

- For use with a relay, wire connections to rocker switch should be 16 gauge minimum.
- Rocker switch and control board must be mounted in areas protected from water or moisture, and at least 6" from flammable materials.
- The control board should be mounted as close to battery as possible to minimize wire run length to prevent voltage drop.

## System Test Equipment

- Production line test stations should be provided with a consistent, reliable power source to operate the system. Power Gear slide systems require use of a fully charged 12 Volt battery for this testing. Power supplies other than batteries, such as invertors, convertors or battery chargers with ratings of less than 70 amps can harm the equipment and thus will void product warranty.
- **NOTE:** Coach lights and other power source drains should be **OFF** when testing the slide-out system.
- After testing, the slide-out system should be wired directly to the battery.
- Note the system number on the operator's manual and place in the coach with the other manuals for the owner to use.