



SLIMRACK[®] PLUS
SLIDE-OUT SYSTEM
TROUBLESHOOTING AND
SERVICE MANUAL

TABLE OF CONTENTS

Introduction	2
Safety	3
System Information	4
Component Descriptions.....	4
Troubleshooting	5
Checking Circuit Breakers.....	5
Obstructions.....	5
Debris In the Rack.....	5
Room not Fully Sealing.....	5
Measurements.....	6
Mode Button.....	7
Mode Button Functions.....	7
Switching Between Operating Modes.....	8
Switching Between Fault Reporting Modes.....	8
Performing A Factory Reset.....	8
LED Indications	9
Factory Reset and Initial Synchronization	10
When to Perform a Factory Reset.....	10
Performing an Initial Synchronization.....	10
Maintenance	13
Wiring Diagram - Towable	14
Wiring Diagram - Motorized	15

Introduction

The Lippert SlimRack® Plus Slide-Out system maximizes interior RV space by providing added comfort and offering a practical solution for additional space needs. This document provides information to assist in determining causes of concerns with the operation of the SlimRack® Plus In-Wall Slide-Out system and detailed instructions on repairing and servicing various components of the system.

Additional information about this product can be obtained from lci1.com/support or by downloading the free LippertNOW app. The app is available on Apple App Store® for iPhone® and iPad® and also on Google Play™ for Android™ users.

Apple App Store®, iPhone®, and iPad® are registered trademarks of Apple Inc.
Google Play™ and Android™ are trademarks of Google Inc.

For information on the assembly or individual components of this product, please visit:
<https://support.lci1.com/slimrack-plus>

NOTE: Images used in this document are for reference only when assembling, installing and/or operating this product. Actual appearance of provided and/or purchased parts and assemblies may differ.

NOTE: Lippert recommends that the following inspections, troubleshooting, component replacement, and verifications be completed only by certified RV technicians.

NOTE: The procedures detailed in this troubleshooting and service manual are written for the professional service technician at a qualified dealer or repair facility.

Safety

Read and understand all instructions before installing or operating this product. Adhere to all safety labels. This manual provides general instructions. Many variables can change the circumstances of the instructions, i.e., the degree of difficulty, operation and ability of the individual performing the instructions. This manual cannot begin to plot out instructions for every possibility, but provides the general instructions, as necessary, for effectively interfacing with the device, product or system. Failure to correctly follow the provided instructions may result in death, serious personal injury, severe product and/or property damage, including voiding of the Lippert limited warranty.

WARNING

The "WARNING" symbol above is a sign that a procedure has a safety risk involved and may cause death or serious personal injury if not performed safely and within the parameters set forth in this manual.

WARNING

Failure to follow instructions provided in this manual may result in death, serious personal injury and/or severe product and property damage, including voiding of the component warranty.

WARNING

The unit **MUST** be supported per manufacturer's recommendations before working underneath. Failure to do so may result in death or serious injury.

WARNING

Unless required by the procedure, do not work on your slide-out system unless the battery is disconnected. Always make sure that the slide-out room path is clear of people and objects before and during operation of the slide-out room. Always keep away from the slide rails when the room is being operated. The gear assembly may pinch or catch on loose clothing causing personal injury.

CAUTION

The "CAUTION" symbol above is a sign that a safety risk is involved and may cause personal injury and/or product or property damage if not safely adhered to and within the parameters set forth in this manual.

CAUTION

Always wear eye protection when performing service, maintenance or installation procedures. Other safety equipment to consider would be hearing protection, gloves and possibly a full face shield, depending on the nature of the task.

CAUTION

Moving parts can pinch, crush or cut. Keep clear and use caution.

System Information

The Lippert SlimRack® Plus Slide-Out is a rack-and-pinion design operated by two 12V DC gear motors. Changes to weight, stroke, weight distribution, rail position, controller, power supply seals, slide toppers, ramps, rollers, etc. all have an effect on the performance of the system.

Component Descriptions

- Rocker switch (Fig. 1) that mounts to the wall.
- The controller (Fig. 2) is sensorless and has no option for programming. The controller constantly learns and refines the synchronization between the two sides of the slide. To ensure the best end user experience, perform the steps described in Performing an Initial Synchronization once at the factory.
- Floor rollers (not supplied by Lippert) that support the slide-out's weight while extending and retracting the slide-out. Only floor rollers approved by Lippert can be used with the system. Contact Lippert for recommended rollers.

Fig. 1

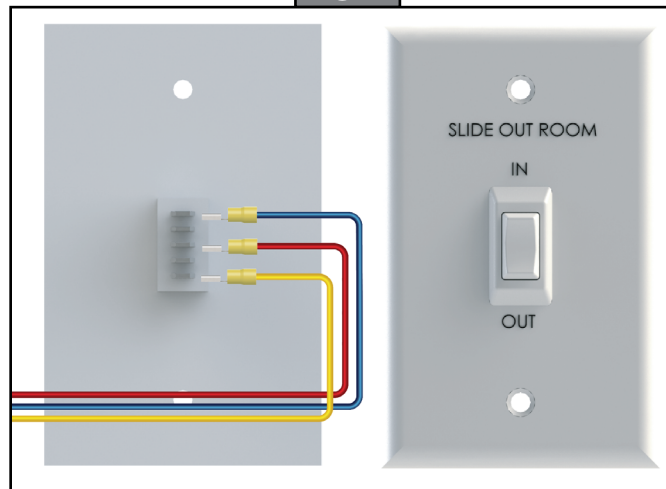
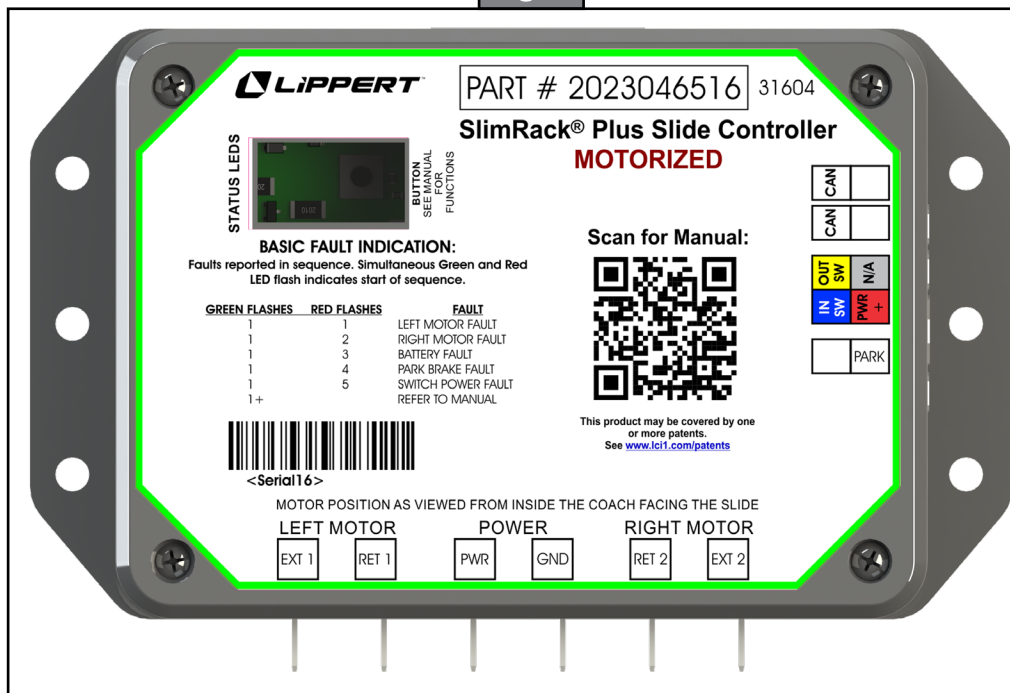

Fig. 2



Troubleshooting

Checking Circuit Breakers

The SlimRack Plus Slide-out requires a minimum of a 30-amp circuit breaker. Check the 12-volt circuit breaker box for blown circuit breakers, and replace any if necessary. Consult the RV manufacturer's documentation for the location of the 12-volt circuit breaker box, and the location of the slide-out controller's circuit breaker. If the circuit breaker blows immediately upon replacement, there is a problem with the wiring to the slide-out controller. Have qualified service personnel check and repair.

Obstructions

Check outside the unit for possible obstructions: tree, post, car, etc. Check inside the unit for any obstructions: luggage, furniture, open cabinets, etc. Also, check for smaller objects that may be wedged under the floor or in the sides of unit. Remove obstructions before proceeding.

Debris In the Rack

Check the sides of the slide room for any dirt or debris. Small dirt clumps or metal shavings can cause the spur gear to bind up and stop the movement of the slide-out. Use compressed air or a dry brush to remove any dirt or debris from the rack before attempting to actuate the system again

Room not Fully Sealing

If the slide stops without an adequate seal, ensure the slide is free of mechanical obstructions. Press the extend/retract switch again until both sides are sealed. If the issue reoccurs after operating the slide normally, perform a factory reset and initial synchronization.

Measurements

1. Measure from the outside edge of the column to the side of the slide out wall (Fig. 3). The standard measurement tolerance should be $3 \frac{7}{8}$ " plus or minus $\frac{1}{8}$ ". Take this measurement on both sides when the room is fully extended and again when the room is 3" from fully retracted.
2. Measure the gear racks for parallelism. There should be less than $\frac{1}{8}$ " difference between the parallel measurements.
3. Check for proper seal engagement (no binding, $\frac{1}{4}$ " nominal overlap).

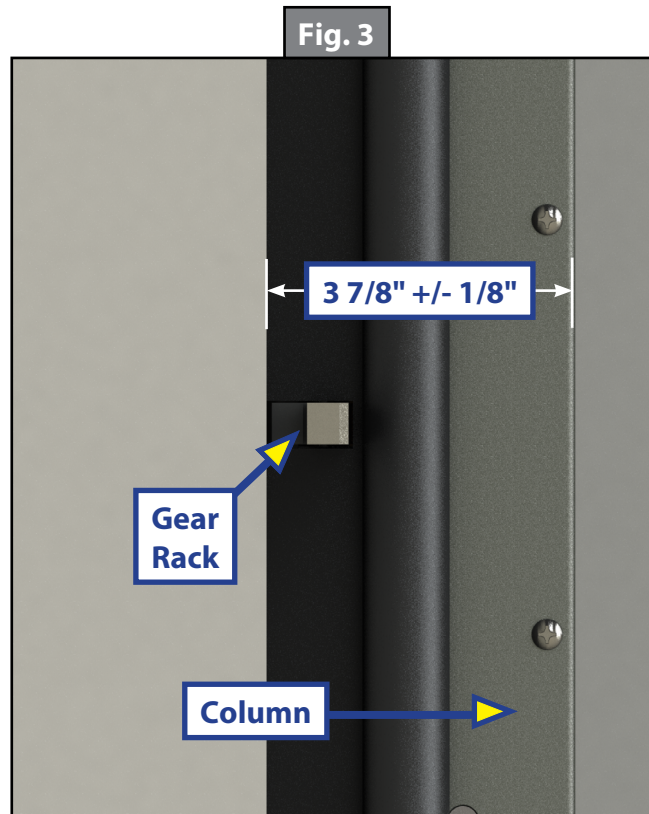

Switching Between Operating Modes

It is possible to switch between operating modes using the mode button. The controller will return to normal operating mode on its own after 2 minutes, even if being driven.

NOTE: When in electronic override mode, electronic protections will be disabled.

Operating Modes		
Presses	Function	Description
7 – hold on the seventh press	Enter Electronic Override Mode	Enter Electronic Override Mode
1 – hold on first press	Return to normal operating mode	Returns the controller to normal operating mode

Switching Between Fault Reporting Modes

In normal operating mode, the controller will report faults by blinking the LEDs in sequences.

It is possible to switch between fault reporting modes using the mode button. The controller will return to basic fault reporting mode on its own after 30 minutes.

NOTE: When in electronic override mode, electronic protections will be disabled.

Fault Reporting Modes		
Presses	Function	Description
1 – hold on first press	Return to normal operating mode	Returns the controller to normal operating mode. When a fault is present, LEDs will blink in sequences listed in the Basic Fault Reporting table.
3 – hold on third press	Enter active DTC reporting mode	When a fault is present, LEDs will blink in sequences in the DTC Reporting table.

Performing A Factory Reset

A factory reset will clear current synchronization. To perform a factory reset, press the mode button 5 times and hold on the 5th press for at least 1 second.

NOTE: After performing a factory reset, users will need to follow the steps under the initial synchronization instructions. Otherwise, the slide will not synchronize properly and may be misaligned or jackknife.

LED Indications

- When driving motors, the green LED and red LED will blink synchronously.
- When indicating faults, the LEDs blink sequentially, report all faults and repeat. The green LED will blink once or twice to indicate the reporting mode, followed by one to several blinks of the red LED to indicate each fault.

Examples

A motor 2 fault:

Green LED blinks once, followed by the red LED blinking 2 times, then repeating. Then both lights will blink at the same time to indicate the beginning of the sequence and the pattern repeats.



A motor 1 fault and a motor 2 fault:

Green LED blinks once, red LED blinks once, green LED blinks once, red LED blinks twice. Then both lights will blink at the same time to indicate the beginning of the sequence and the pattern repeats.

- When switching between modes, both LEDs will blink to acknowledge the user selection.

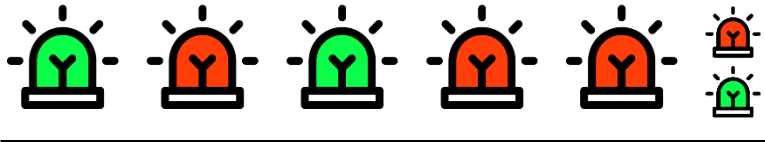

Factory Reset

After pressing the switch 5 times to initiate a factory reset, the red and green lights will both blink 5 times.



Electronic Override Mode

When in electronic override mode, the LEDs will rapidly blink one after another while the mode is active. Active fault warnings and other electronic protections will be disabled.



Basic Fault Reporting Mode Table				
Green LED (1 = basic fault reporting mode, 2 = DTC reporting mode)	Red LED	DTC: Diagnostic Trouble Code	Description	Troubleshooting Steps
1 (Basic fault)	1	Motor 1 fault	There is a problem with the motor 1 circuit.	Check connections on the motor, the controller and check the wire harness for damage. Motor may need to be replaced.
1 (Basic fault)	2	Motor 2 fault	There is a problem with the motor 2 circuit.	Check connections on the motor, the controller and check the wire harness for damage. Motor may need to be replaced.
1 (Basic fault)	3	Battery fault	There is a problem with the detected battery power.	Ensure the battery is fully charged and try actuating again.
1 (Basic fault)	4	Parking brake fault	There is a problem with the parking brake signal.	Check to ensure the parking brake is engaged.
1 (Basic fault)	5	Switch power fault	There is a problem with the switch circuit.	Check connections on the switch, the controller and check the wire harness for damage. Switch may need to be replaced.

Factory Reset and Initial Synchronization

After maintenance and during troubleshooting, a factory reset may need to be performed (See Performing a Factory Reset section). Then, after performing a factory reset, perform an initial synchronization to ensure the sides of the slide-out are properly aligned.

When to Perform a Factory Reset

- After swapping motors.
- After swapping, replacing, or repairing motor harnesses.
- After reversing a motor's polarity to correct slide travel direction.
- After repairing faulty motor harnesses.
- After swapping controllers to operate different slides – even known good motors. Each slide is unique.
- During the initial installation of a controller on a slide fresh from factory.

Performing an Initial Synchronization

1. Retract slide-out until controller shuts motors off.
2. Confirm slide-out is fully retracted and controller does not report any faults.
3. Extend slide-out until controller shuts motors off.
4. Confirm slide-out is fully extended and controller does not report any faults.
5. Retract slide-out until controller shuts motors off.
6. Confirm slide-out is fully retracted and controller does not report any faults.

DTC Reporting Mode Table

Green LED (1 = basic fault reporting mode, 2 = DTC reporting mode)	Red LED	DTC: Diagnostic Trouble Code	Description	Troubleshooting Steps
2 (DTC)	1	DTC_MOTOR_OUTPUT_1_SHORT_TO_GND	One of the motor 1 outputs is shorted to ground.	Check motor harness for damage.
2 (DTC)	2	DTC_MOTOR_OUTPUT_2_SHORT_TO_GND	One of the motor 2 outputs is shorted to ground.	Check motor harness for damage.
2 (DTC)	3	DTC_MOTOR_OUTPUT_1_SHORT	The motor 1 outputs are shorted together.	Check motor harness for damage.
2 (DTC)	4	DTC_MOTOR_OUTPUT_2_SHORT	The motor 2 outputs are shorted together.	Check motor harness for damage.
2 (DTC)	5	DTC_MOTOR_OUTPUT_1_OPEN	One of the motor 1 outputs is open.	Check connections on motor and controller, check harness for damage.
2 (DTC)	6	DTC_MOTOR_OUTPUT_2_OPEN	One of the motor 2 outputs is open.	Check connections on motor and controller, check harness for damage.
2 (DTC)	7	DTC_BATTERY_DROPOUT	Actuation attempted with bad battery or low-side-short-to-battery introduced after actuation began.	Check to ensure the battery is fully charged. Check controller power connection for damage.
2 (DTC)	8	DTC_OPERATING_VOLTAGE_DROPOUT	Detected low battery voltage.	Ensure the battery is fully charged and attempt to actuate again.
2 (DTC)	9	DTC_BATTERY_VOLTAGE_HIGH	Detected high battery voltage.	Ensure a 12V nominal battery is being used. Voltage should not be higher than 16V.
2 (DTC)	10	DTC_PARK_BRAKE_SWITCH_FAULT	Parking brake was not engaged when movement attempted.	Ensure parking brake is engaged and try again.

DTC Reporting Mode Table

Green LED (1 = basic fault reporting mode, 2 = DTC reporting mode)	Red LED	DTC: Diagnostic Trouble Code	Description	Troubleshooting Steps
2 (DTC)	11	DTC_MOTOR_OUTPUT_1_OPEN_B	Motor 1 output became open after startup.	Check controller and motor for loose connections. Check harness for damage.
2 (DTC)	12	DTC_MOTOR_OUTPUT_2_OPEN_B	Motor 2 output became open after startup.	Check controller and motor for loose connections. Check harness for damage.
2 (DTC)	13	DTC_MOTOR_OUTPUT_1_SHORT_TO_BATT	Motor 1 output shorted to battery or onboard motor driver failed closed.	Check motor and harness for damage.
2 (DTC)	14	DTC_MOTOR_OUTPUT_2_SHORT_TO_BATT	Motor 2 output shorted to battery or onboard motor driver failed closed.	Check motor and harness for damage.
2 (DTC)	15	DTC_MOTOR_OUTPUT_1_SHORT_TO_BATT_B	Motor 1 short-to-battery after motor started moving.	Check controller and motor for loose connections. Check harness for damage.
2 (DTC)	16	DTC_MOTOR_OUTPUT_2_SHORT_TO_BATT_B	Motor 2 short-to-battery injected after motor started moving.	Check controller and motor for loose connections. Check harness for damage.
2 (DTC)	17	DTC_MOTOR_OUTPUT_1_OVER_CURRENT	High current detected on motor 1 output. This DTC will only be triggered when operating in Electronic Override mode.	Check motor and harness for damage.
2 (DTC)	18	DTC_MOTOR_OUTPUT_2_OVER_CURRENT	High current detected on motor 2 output. This DTC will only be triggered when operating in Electronic Override mode.	Check motor and harness for damage.

DTC Reporting Mode Table

Green LED (1 = basic fault reporting mode, 2 = DTC reporting mode)	Red LED	DTC: Diagnostic Trouble Code	Description	Troubleshooting Steps
2 (DTC)	19	DTC_FUSE_1_OPEN	On-board, self-resetting fuse for motor output 1 is open.	Let controller cool down and attempt to actuate again.
2 (DTC)	20	DTC_FUSE_2_OPEN	On-board, self-resetting fuse for motor output 2 is open.	Let controller cool down and attempt to actuate again.
2 (DTC)	21	Reserved		
2 (DTC)	22	Reserved		
2 (DTC)	23	Internal controller failure		Power cycle. If issue persists, call Customer Service Center.
2 (DTC)	24	Internal controller failure		Power cycle. If issue persists, call Customer Service Center.
2 (DTC)	25	DTC_BATTERY_VOLTAGE_LOW	Battery voltage below 9V had been detected.	Ensure battery is fully charged and attempt to actuate again.
2 (DTC)	26	DTC_SWITCH_PWR_SHORT_TO_GROUND	Switch power output shorted to ground.	Check the external switch, its connectors and the harness for damage.
2 (DTC)	27	Synchronization issue		Factory reset the controller and perform initial synchronization.
2 (DTC)	28	System status DTC		No action required.
2 (DTC)	29	System status DTC		No action required.

Maintenance

The Lippert slide-out system has been designed to require very little maintenance. To ensure the long life of the slide-out system, follow these simple procedures:

1. When slide-out room is extended, visually inspect the slide gear rack assemblies. Check for excess buildup of dirt or other foreign material. Remove any debris that may be present.
2. If the system squeaks or makes any noises, hand apply a dry lubricant to prevent and/or stop squeaking.

Wiring Diagram - Towable

Fig. 5

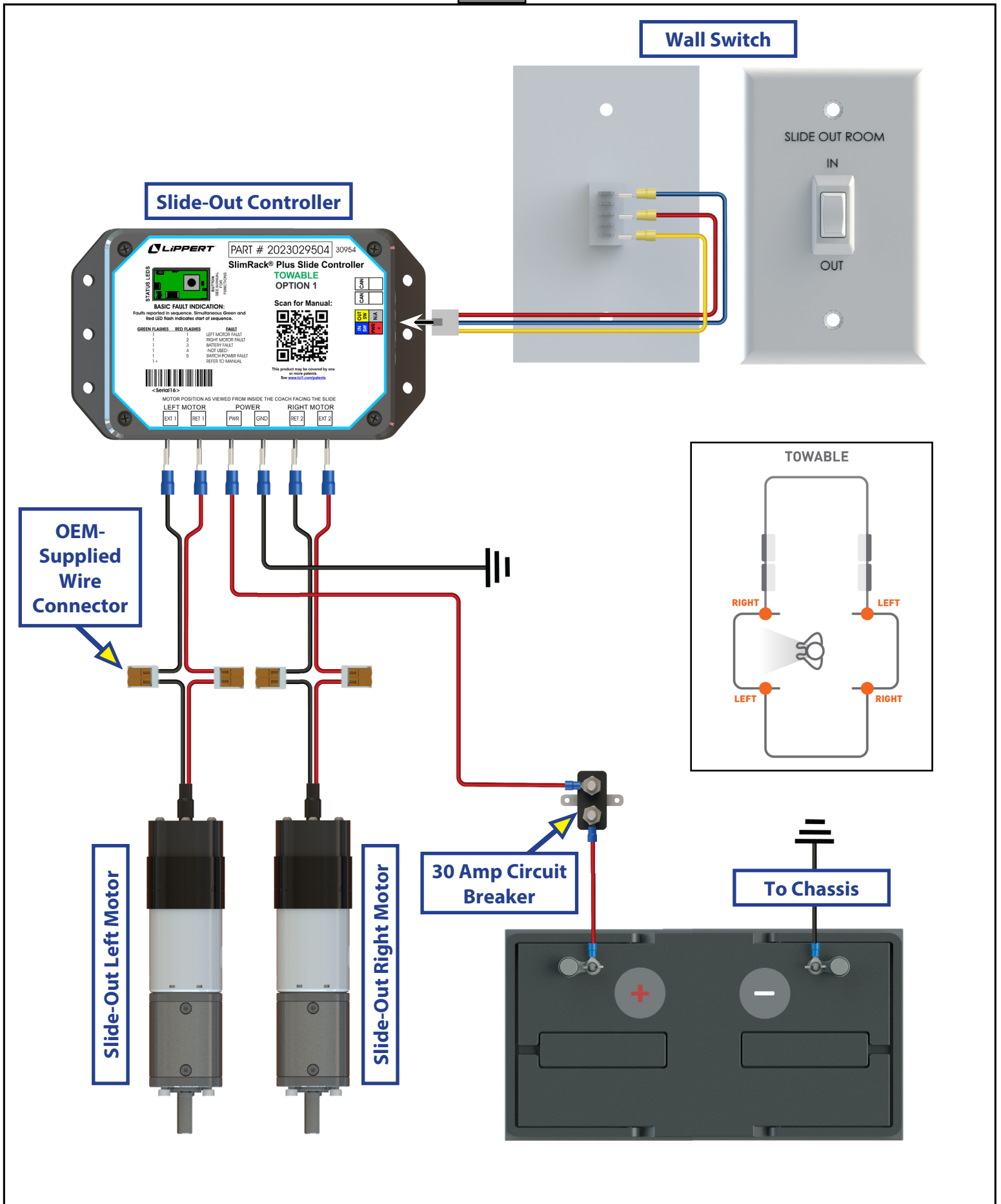

Wiring Diagram - Motorized

Fig. 6

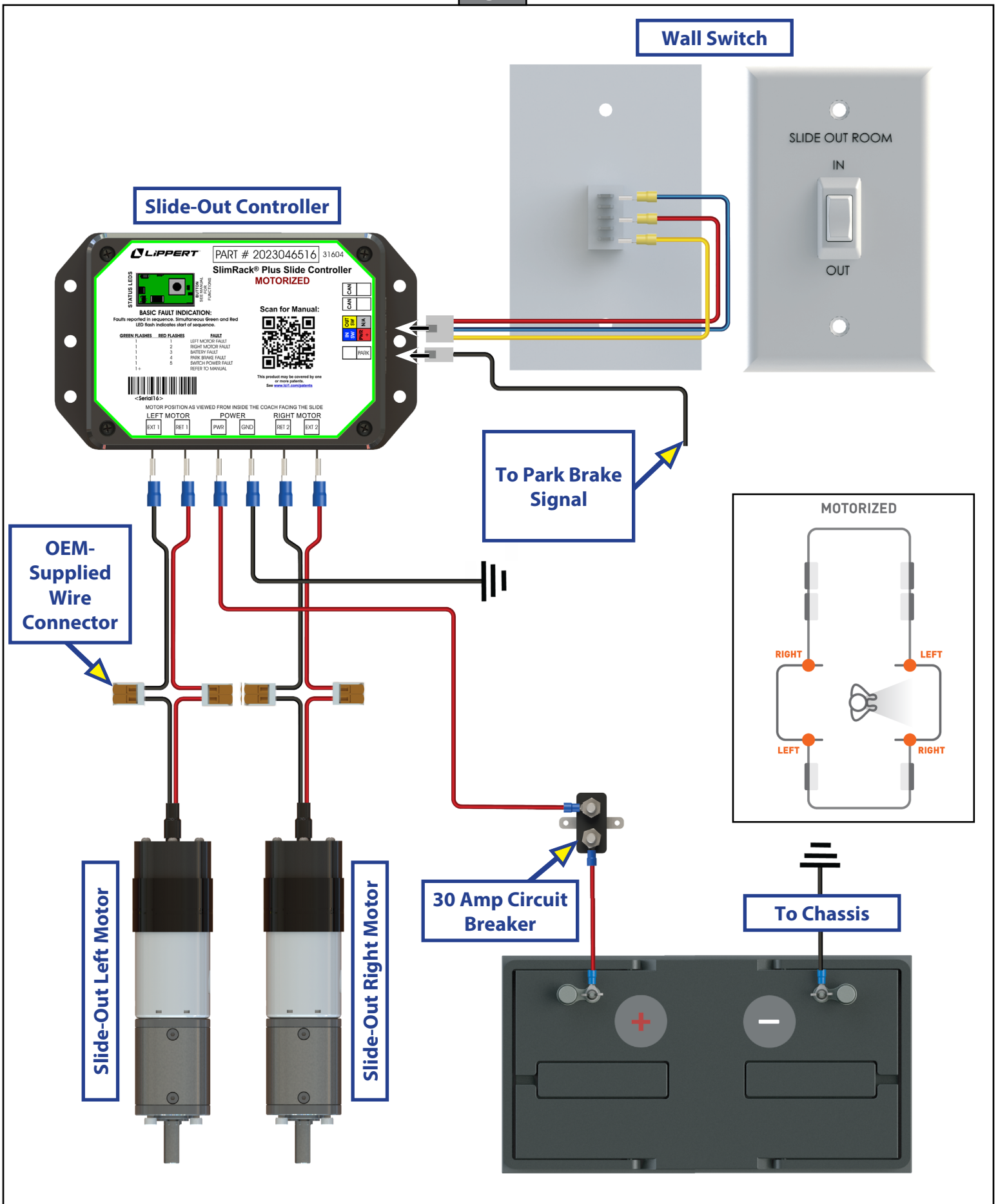



The contents of this manual are proprietary and copyright protected by Lippert. Lippert prohibits the copying or dissemination of portions of this manual unless prior written consent from an authorized Lippert representative has been provided. Any unauthorized use shall void any applicable warranty. The information contained in this manual is subject to change without notice and at the sole discretion of Lippert. Revised editions are available for free download from lippert.com.

Please recycle all obsolete materials.

For all concerns or questions, please contact Lippert
Ph: 432-LIPPERT (432-547-7378) | Web: lippert.com | Email: customerservice@lci1.com