



Master Owner's Manual

LEVELING & STABILIZATION

PART II

Master Owner's Manual

The Master Owner's Manual is intended to provide information on Lippert's most widely used products. Products described in the Master Owner's Manual may not be on every trailer. The trailer may also have products not included in this manual. All manual information is subject to change without notice. Revised editions will be available for free download at lippert.com/support. Manual information is considered factual until made obsolete by a revised version. Manual information may be distributed as a complete document only, unless Lippert provides explicit consent to distribute individual parts.

User's Note

The Table of Contents is interactive. Click on the title to navigate to the first page of the manual. In the top right corner see "**RETURN to TOC**" that will return you to the Table of Contents.

TABLE OF CONTENTS

Hydraulic Leveling (Towable)

Level-Up with OneControl Touch Panel Owner's Manual

Ultra Level Motorized Leveling Owner's Manual

Hydraulic Leveling with LCD Touchpad (4 Point/ 3 Valve Motorized) Owner's Manual

Patriot Jack Systems Leveling Owner's Manual

Hydraulic Leveling (4 Point/4 Valve Sprinter) Owner's Manual

Titan Leveling System (4 Valve/ 4 Jack) Owner's Manual

Titan Leveling Systems for 5th Wheel Owner's Manual



LEVEL UP[®] WITH
ONECONTROL[™] TOUCH PANEL
OWNER'S MANUAL

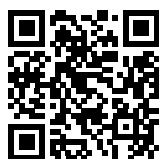

Scan for product support

Table of Contents

System Information	3
Safety Information	3
Red/Green LED Indicator.....	4
Touch Pad Diagram - Auto Leveling Control	4
Operation - Auto Leveling Control Touch Pad	5
Unhitching Instructions.....	5
Auto Level.....	5
Auto Level Sequence.....	5
Hitch Recognition - Reconnecting to Tow Vehicle.....	5
Touch Panel Diagram - MyRV OneControl Touch Panel	6
Operation - MyRV OneControl Touch Panel	7
Standard Mode and Menu.....	7
Basic Jack Operation.....	7
Unhitching Instructions.....	8
Auto Level.....	8
Auto Level Sequence.....	8
Hitch Recognition - Reconnecting to Tow Vehicle.....	8
Zero Point Calibration.....	9
To Set the Zero Point.....	9
Touch Pad Diagram - OneControl App From MyRV	10
Operation - OneControl App	11
Accessing the OneControl App.....	11
Standard Mode and Menu.....	12
Basic Jack Operation.....	12
Unhitching Instructions.....	13
Auto Level.....	13
Auto Level Sequence.....	13
Touch Pad Diagram - Linc Remote Control - Optional	13
Configuring Linc Remote to Sync to MyRV One Control Touch Panel.....	14
Basic Jack Operation.....	15
Unhitching Instructions.....	15
Auto Level.....	15
Auto Level Sequence.....	15
Maintenance	16
Fluid Recommendation.....	16
Preventative Maintenance.....	16
Manual Override	16
Troubleshooting	18
Error Display In LCD Screen.....	18
Notes	19

System Information

The Lippert Level Up® OneControl™ Touch Panel is an automatic leveling system control for fifth wheel applications. It interfaces to the Lippert Level Up pump/jack system to level the trailer. The system utilizes one main control board and a separate waterproof remote level sensor to measure and manage level point, and can be operated from several user interface devices, including:

Auto Leveling Control Touch Pad - Mounted outside the trailer within view of the hitch.

MyRV® OneControl Touch Panel (OCTP) - Mounted on a wall inside the living space of the trailer.

MyRV OneControl Leveling App - The app is available on Apple App Store® for iPhone® and iPad® and also on Google Play™ for Android™ users.

Linc® Remote Control - Optional.

The Lippert Level Up OneControl Touch Panel is for fifth wheel applications only.

Additional information about this product can be obtained from [lci1.com/support](https://support.lci1.com/support) or by downloading the free LippertNOW app. The app is available on Apple App Store® for iPhone® and iPad® and also on Google Play™ for Android™ users.

Apple App Store®, iPhone®, and iPad® are registered trademarks of Apple Inc.

Google Play™ and Android™ are trademarks of Google Inc.

For information on the assembly or individual components of this product, please visit:

<https://support.lci1.com/towable-br-level-up-support-towable-level-up-br-octp>

NOTE: Images used in this document are for reference only when assembling, installing and/or operating this product. Actual appearance of provided and/or purchased parts and assemblies may differ.

Safety Information

Read and understand all instructions and safety labels before starting any procedures stated in this manual. Adhere to all safety labels to prevent serious personal injury and/or product damage. Failure to follow instructions and safety labels may void product warranty.

Be sure to park the trailer on solid, level ground. Ensure all jack landing locations are cleared of debris and obstructions and also free of depressions. People and pets should be clear of trailer while operating the leveling system. Ensure the battery of the trailer is fully charged or that the trailer is plugged into shore power prior to attempting to operate the system. Level Up requires a minimum of 12.75V DC from the battery for proper operation. Be sure to keep hands and other body parts clear of fluid leaks. Hydraulic fluid leaks in the Lippert Leveling System may be under high pressure and can cause serious skin-penetrating injuries.

WARNING

The "WARNING" symbol above is a sign that a procedure has a safety risk involved and may cause death or serious personal injury if not performed safely and within the parameters set forth in this manual.

WARNING

Failure to act in accordance with the following may result in death, serious injury, trailer damage or voiding of the component warranty.

WARNING

Lippert recommends that a trained professional be employed to change the tires on the trailer. Ensure that the trailer is properly supported with jack stands, or other adequate devices, under the frame of the trailer prior to commencing any service or repair procedure. Any attempts to change the tires or perform other service while trailer is supported solely by the Lippert Level Up could result in death, serious injury, trailer or property damage.

Touch Pad Diagram - Auto Leveling Control

Fig. 1

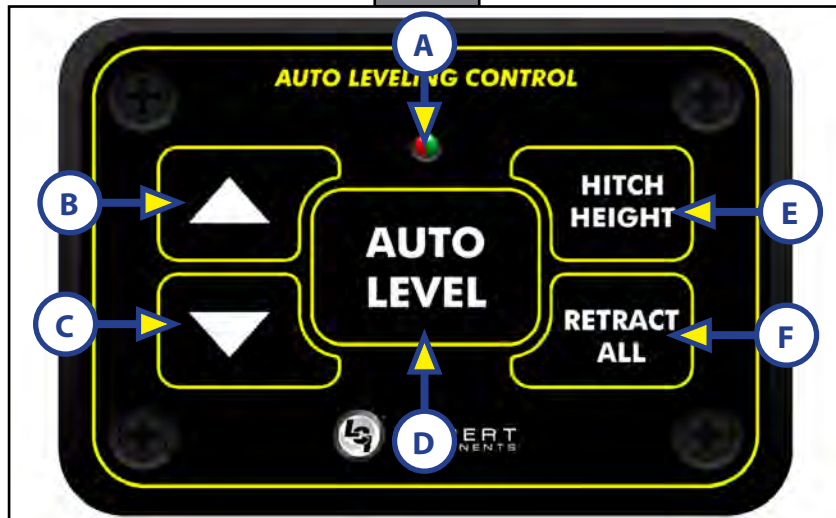

Callout	Description	
A	Red/Green LED - Indicates the status of the system.	
B	Up Arrow - Extends front jacks (landing gear).	To turn on the touch pad, press the Up and Down arrow buttons at the same time.
C	Down Arrow - Retracts front jacks (landing gear).	
D	Auto Level Button - Places leveling system into auto level mode.	
E	Hitch Height Button - Initiates the Hitch Recognition feature.	
F	Retract All Button - Places leveling system into full retract mode.	

Red/Green LED Indicator

What Is Happening?	Why?
Off	Touch pad is locked.
Solid Green	Touch pad is active.
Blinking Green	Jacks are moving.
Solid Red	Low battery.
Blinking Red	Error - Refer to OneControl™ Touch Panel screen or the Leveling App for the specific error, then consult the Troubleshooting section of this manual to clear the error.

Operation - Auto Leveling Control Touch Pad

Unhitching Instructions

NOTE: Prior to unhitching from the tow vehicle, ensure trailer is parked on a level surface and chock the tires of the trailer.

1. To turn on the touch pad, press both "UP" and "DOWN" arrows (Fig. 1B and Fig. 1C) at the same time. The green indicator LED (Fig. 1A) will turn on.

NOTE: The touch pad will remain on as long as the user is pressing buttons. It will time out after approximately 7 minutes without use.

2. Press the "UP" arrow (Fig. 1B) to extend the front jacks and lift the front of trailer to take the weight of the trailer off of the hitch.
3. Uncouple the trailer connection on the tow vehicle.
4. Pull tow vehicle away and park at a safe distance.

Auto Level

NOTE: Once the automatic leveling cycle has been started, it is important that there is no movement in the trailer until the trailer has completed the leveling process. Failure to remain still during the leveling cycle could have an effect on the performance of the leveling system.

1. After unhitching from tow vehicle press "AUTO LEVEL" (Fig. 1D).

NOTE: Pressing any button during an Auto Level sequence will abort the auto leveling cycle.

Auto Level Sequence

NOTE: Sequence may vary slightly based on the height of the trailer king pin prior to leveling.

1. When the Auto Level sequence begins, the front of the trailer will seek a position near a level state, then the trailer will level from front to back.
2. The left side jack(s) extend to ground (left mid and left rear).
3. The right side jack(s) extend to ground (right mid and right rear).
4. Jack pairs will extend as needed in order to level the trailer.

NOTE: Step 4 may repeat several times if the controller deems necessary.

NOTE: If the AUTO LEVEL sequence does not perform as described above, place the system in manual mode and test that the jacks operate correctly by pushing their coordinating buttons on the OneControl Touch Panel inside the trailer; e.g., "FRONT" button operates only the front jacks, etc. See Operation - MyRV OneControl Touch Panel in this manual.

Hitch Recognition - Reconnecting to Tow Vehicle

1. To turn on the touch pad, press both "UP" and "DOWN" arrows (Fig. 1B and Fig. 1C) at the same time. The green indicator LED (Fig. 1A) will turn on.
2. Press "HITCH HEIGHT" (Fig. 1E). The rear jacks will retract.
3. The front of the trailer will raise to the height where the auto level sequence was started.

NOTE: If the front of the trailer was below level when the Auto Level process was initiated, the hitch recognition feature will retract the rear jacks but will not retract the front jacks to lower the trailer to the initial hitch height. This feature helps prevent injury and/or damage to anything underneath the trailer.

4. Connect tow vehicle and make sure trailer and hitch are connected and locked.
5. Press "RETRACT ALL" System will immediately retract all jacks.

NOTE: A visual inspection of the jacks in the retract position is recommended after completing Auto Retract.

Touch Panel Diagram - MyRV OneControl Touch Panel

Fig. 2 - Leveling Standard Mode

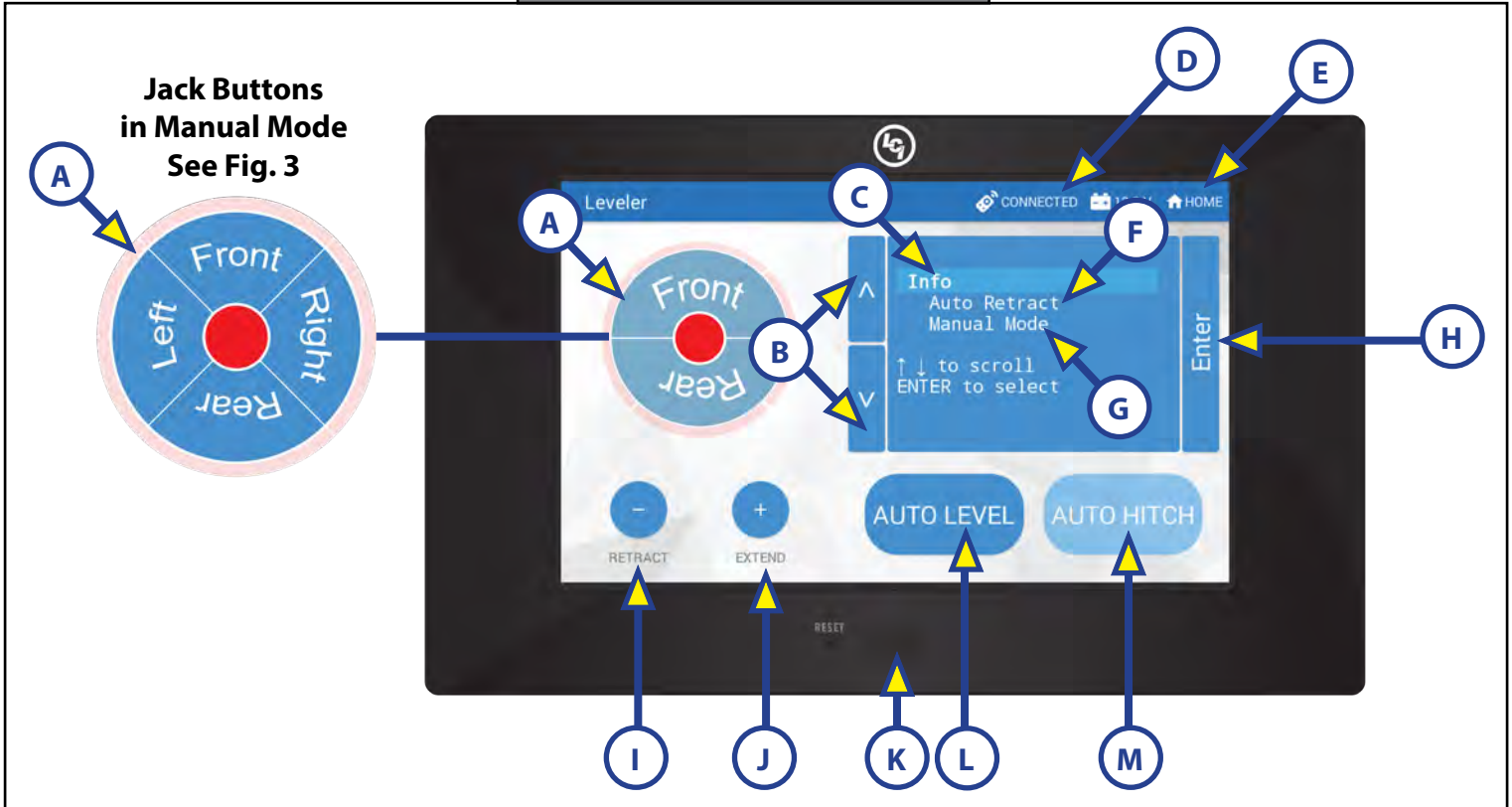

Callout	Description
A	Jack Buttons - Select front, rear, right and left jacks to be operated depending on mode. Jacks available to be operated will be highlighted in blue. In Standard Mode (Fig. 2), only front and rear jacks are available to be operated. In Manual Mode (Fig. 3), all jacks are available to be operated.
B	Up and Down Arrows - Scrolls through options on screen.
C	Info - Displays system information, e.g. angle, jack stroke or software version.
D	Connected Icon - Press 6 times to program zero point/ wireless configurations.
E	Home Icon - Returns screen to home page.
F	Auto Retract - Enters Auto Retract mode to retract all jacks.
G	Manual Mode - Enters Manual Mode to manually operate jacks.
H	Enter - Push to select various modes.
I	Retract - Retracts jacks in several modes. Jacks available will be highlighted in blue.
J	Extend - Extends jacks in several modes. Jacks available will be highlighted in blue.
K	Power Button - Turns touch panel on and off.
L	Auto Level - Starts the Auto Level sequence.
M	Auto Hitch - Returns trailer to previous hitch height for reconnecting to tow vehicle.

Operation - MyRV OneControl Touch Panel

Standard Mode and Menu

To reach Standard Mode (Fig. 2) for leveling:

1. Power on the OneControl Touch Panel (Fig. 2K).
2. Press "MyRV Control Panel" on the main screen.
3. Press the "Leveler" icon.
4. The screen will show the system menu (Fig. 2) for Standard Mode. The front jacks can be extended/retracted in Standard Mode. Rear jacks can be retracted from this mode.

Basic Jack Operation

While in Standard Mode:

1. Press "RETRACT" (Fig. 2I) or "EXTEND" (Fig. 2J), then "FRONT" to retract or extend front jacks.
2. Press "RETRACT" and "REAR" to retract rear jacks.
3. Press the "AUTO LEVEL" (Fig. 2L) button to start the auto leveling sequence.
4. Press the "AUTO HITCH" (Fig. 2M) button to start the hitch recognition sequence when reconnecting to the tow vehicle.
5. Use the "UP" or "DOWN" arrow (Fig. 2B) buttons to cycle through the menu screen options:
 - A. Info:** Scroll to "INFO" (Fig. 2C) and press "ENTER" (Fig. 2H) button to display system information, e.g., angle, jack stroke or software version.
 - B. Auto Retract:** Scroll to "AUTO RETRACT" (Fig. 2F) and press "ENTER" button to start the "Auto Retract" sequence, which will retract all jacks.
 - C. Manual Mode:** Scroll to "MANUAL MODE" (Fig. 2G) and press "ENTER" button to start Manual Level operation. Jacks operate in pairs. Use "RETRACT" or "EXTEND" to operate front jacks, right rear and left rear jacks.

NOTE: Upon entering Manual Mode, a tutorial on operating the jacks will appear on the screen. Press "OK" to clear the tutorial. To delete the tutorial, click the "Don't show this again" box in the bottom right of the screen.

- I. Press "RETRACT" (Fig. 3A) or "EXTEND" (Fig. 3B), then "FRONT" (Fig. 3) to operate front jacks.
- II. Press "EXTEND" or "RETRACT," then "REAR" to operate rear jacks (right rear, right mid, left rear and left mid).
- III. Press "EXTEND" or "RETRACT," then "RIGHT" to operate right jacks (right mid and right rear).
- IV. Press "EXTEND" or "RETRACT," then "LEFT" to operate left jacks (left mid and left rear).

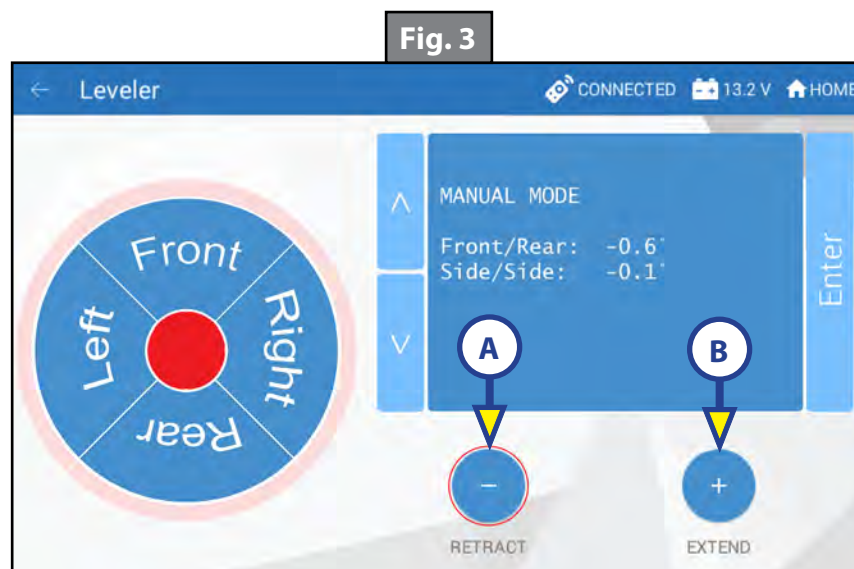

Unhitching Instructions

NOTE: Prior to unhitching from the tow vehicle, ensure trailer is parked on a level surface and chock the tires of the trailer.

1. Push touch panel "ON/OFF" (Fig. 2K) to turn system on (See "Standard Mode and Menu" to reach standard mode.)
2. Push "EXTEND" (FIG. 2J), then "FRONT" button (Fig. 2) to extend front jacks and lift front of the trailer to take the weight of the trailer off of the hitch.
3. Uncouple the trailer connection on the tow vehicle.
4. Pull tow vehicle away and park at a safe distance.

Auto Level

NOTE: Once the automatic leveling cycle has been started, it is important that there is no movement in the trailer until the trailer has completed the leveling process. Failure to remain still during the leveling cycle could have an effect on the performance of the leveling system.

1. After unhitching from tow vehicle press "AUTO LEVEL" (Fig. 2L).

NOTE: Pressing "ABORT" during an Auto Level sequence will abort the auto leveling cycle.

Auto Level Sequence

NOTE: Sequence may vary slightly based on the height of the trailer king pin prior to leveling.

1. When the Auto Level sequence begins, the front of the trailer will seek a position near a level state, then the trailer will level from front to back.
2. The left side jack(s) extend to ground (left mid and left rear).
3. The right side jack(s) extend to ground (right mid and right rear).
4. Jack pairs will extend as needed in order to level the trailer.

NOTE: Step 4 may repeat several times if the controller deems necessary.

NOTE: If the "AUTO LEVEL" sequence does not perform as described above, place the system in manual mode and test that the jacks operate correctly by pushing their coordinating buttons on the touch panel; e.g., "FRONT" button operates only the front jacks, etc.

Hitch Recognition - Reconnecting to Tow Vehicle

1. Push touch panel "ON/OFF" (Fig. 2K) to turn system on (See "Standard Mode and Menu" to reach standard mode.)
2. Press "AUTO HITCH" (Fig. 2M). Rear jacks will retract.
3. The front of the trailer will raise to the height where the auto level sequence was started.

NOTE: If the front of the trailer was below level when the Auto Level process was initiated, the hitch recognition feature will retract the rear jacks but will not retract the front jacks to lower the trailer to the initial hitch height. This feature helps prevent injury and/or damage to anything underneath the trailer.

4. Connect tow vehicle and make sure trailer and hitch are connected and locked.
5. On the Standard Mode screen (Fig. 2) use the "UP" and "DOWN" arrows (Fig. 2B) to scroll to "AUTO RETRACT" (Fig. 2F).
6. Push "ENTER" (Fig. 2H). System will immediately retract all jacks.

NOTE: A visual inspection of the jacks in the retract position is recommended after completing Auto Retract.

Zero Point Calibration

The "Zero Point" is the programmed point that the trailer will return to each time the Auto Level feature is used. The "Zero Point" must be programmed prior to using the Auto Level feature to ensure the proper operation of the system. The "Zero Point" feature is only available on the OneControl Touch Panel with this system.

NOTE: Prior to starting this procedure, double check all connections on the controller, jacks, and touch panel.

NOTE: When calibrating Zero Point, the user has full manual control over the jacks. See "Basic Jack Operation - Manual Mode" to adjust to the desired level position. Press the enter button to set.

To Set the Zero Point

NOTE: The following procedure works from Standard Mode only. (See "Standard Mode and Menu" to reach standard mode.)

1. Press the "CONNECTED" icon (Fig. 4A) at the top of the leveling screen quickly 6 times. Wait a few seconds until the gear icon with "OPTIONS" appears (Fig. 5A).
2. Press the gear icon with "OPTIONS" (Fig. 5A).
3. The screen will show "SET UP: Zero Mode Press Enter" (Fig. 6).
4. Press the "Enter button" (Fig. 6A).
5. The touch pad will present options for further leveling of the trailer if needed. The screen will also state "ZERO POINT CALIBRATION - Press Enter to Set" (Fig. 7).
6. Press "ENTER" (Fig. 7A).
7. Screen will show "Zero Point Stability Check ... Please Wait" (Fig. 8), followed by "Zero Point Set" (Fig. 9).

Fig. 4

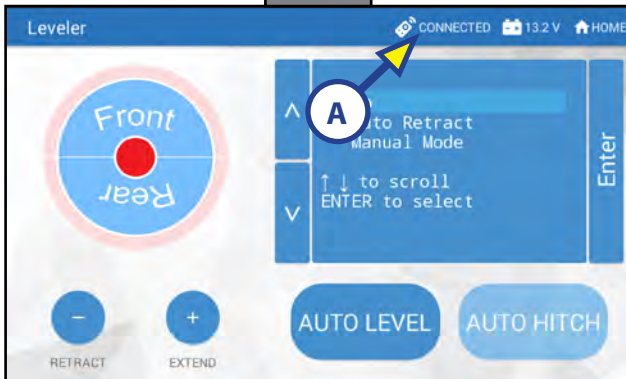

Fig. 5



Fig. 6

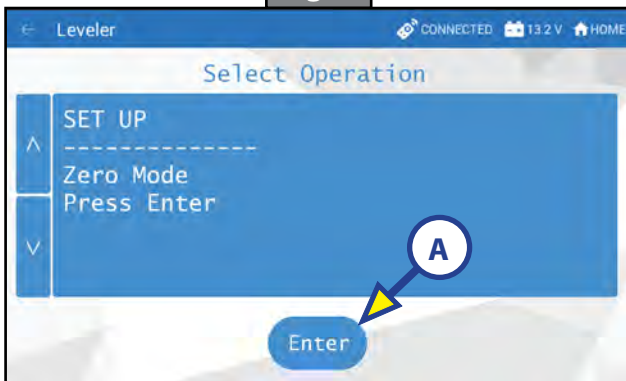

Fig. 7



Fig. 8

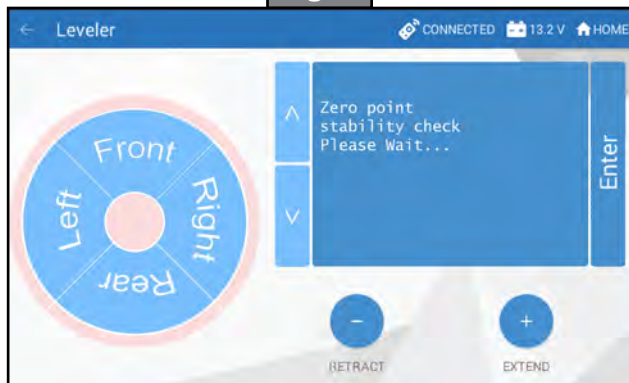
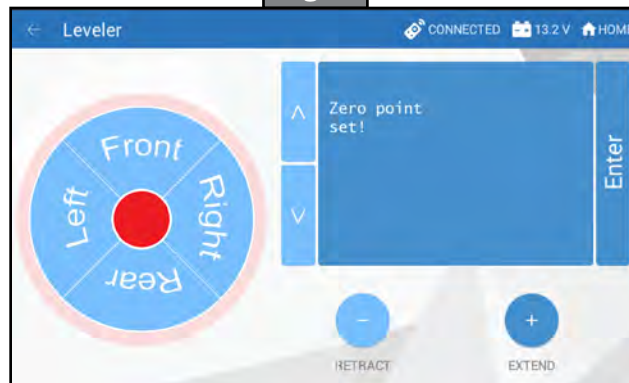

Fig. 9



Touch Pad Diagram - OneControl App From MyRV

NOTE: The One Control Leveling App is available on iTunes for iPhone and iPad and also on Google Play for Android users.

Fig. 10

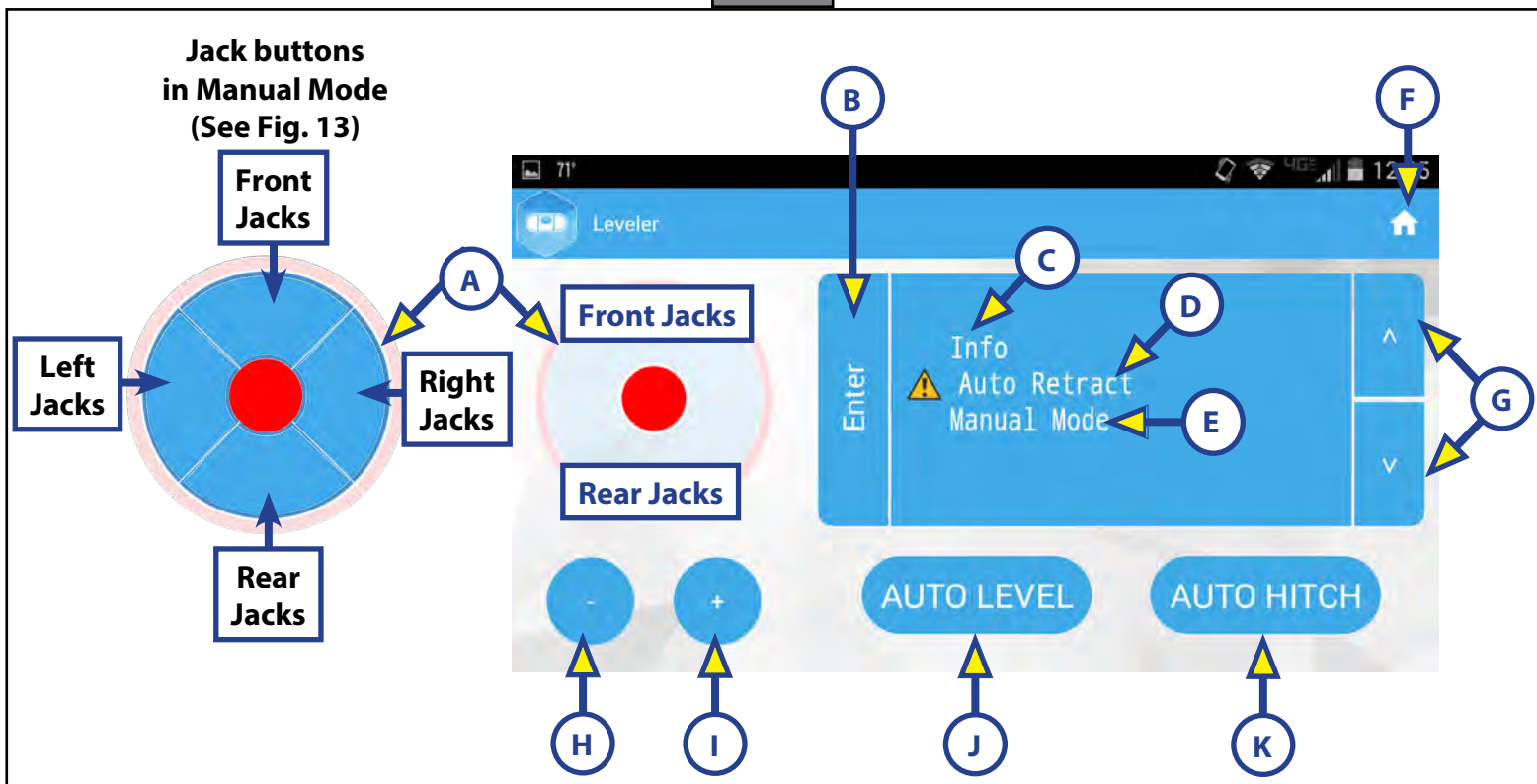

Callout	Description
A	Jack Buttons - Select front, rear, right and left jacks to be operated depending on mode. Jacks available to be operated will be highlighted in blue. In Standard Mode (Fig. 10), only front and rear jacks are available to be operated. In Manual Mode (Fig. 12), all jacks are available to be operated.
B	Enter - Push to activate various modes.
C	Info - Displays system information, e.g., angle, jack stroke, software version.
D	Auto Retract - Enters Auto Retract mode to retract all jacks.
E	Manual Mode - Enters Manual Mode to manually operate jacks.
F	Home Icon - Returns screen to home page.
G	Up and Down Arrows - Scroll through options on screen.
H	Retract - Retracts jacks in several modes. Jacks available will be highlighted in blue.
I	Extend - Extends jacks in several modes. Jacks available will be highlighted in blue.
J	Auto Level - Starts the Auto Level sequence.
K	Auto Hitch - Returns trailer to previous hitch height for reconnecting to tow vehicle.

Operation - OneControl App

Accessing the OneControl App

1. Turn on the trailer to provide power to the trailer's wireless network.
2. Navigate to the device's (smart phone, tablet, etc.) wifi settings. Turn wireless feature on and connect to the MyRV wireless network.

NOTE: If this is the first time connecting to the MyRV wireless network, a password will be required. The password is located on the trailer's wifi hub (Fig. 11).

3. Open the OneControl application on the compatible device.

NOTE: If the device states "Unresolved Network Connection," retry connecting to the MyRV wireless network and/or wait for the connection to resolve and display "Connected" under the MyRV wireless connection.

4. The application will request the user "Agree" to an end user license agreement, create a PIN and "Re-enter PIN to confirm."
5. The OneControl app will now display all functions. Choose "Leveler."



Standard Mode and Menu

Standard Mode is the mode launched when the OneControl app "Leveler" function is powered up. The screen will show the system menu (Fig. 10). The front jacks can be extended/retracted in Standard Mode. Rear jacks can be retracted from this mode.

Basic Jack Operation

While in Standard Mode:

1. Press "RETRACT" (Fig. 10H) or "EXTEND" (Fig. 10I) and "FRONT" (Fig. 10) to extend or retract front jacks.
2. Press "RETRACT" and "REAR" (Fig. 10) to retract rear jacks.
3. Press the "AUTO LEVEL" (Fig. 10J) button to start the leveling sequence.
4. Press the "AUTO HITCH" (Fig. 10K) button to start the hitch recognition sequence when reconnecting to tow vehicle.
5. Use the "UP" or "DOWN" arrow buttons (Fig. 10G) to cycle through the menu options:
 - A. **Info:** Scroll to "INFO" (Fig. 10C) and press "ENTER" button to display system information, e.g., angle, jack stroke or software version.
 - B. **Auto Retract:** Scroll to "AUTO RETRACT" (Fig. 10D) and press "ENTER" button to start the Auto Retract sequence.
 - C. **Manual Mode:** Scroll to "MANUAL MODE" (Fig. 10E) and press "ENTER" button to start Manual Level operation. Jacks operate in pairs. Use "RETRACT" or "EXTEND" to operate front jacks and rear jacks.
 - I. Press "RETRACT" (Fig. 12A) or "EXTEND" (Fig. 12B), then FRONT (Fig. 12C) to operate front jacks.
 - II. Press "RETRACT or "EXTEND," then "REAR" (Fig. 12D) to operate rear jacks (right rear, right mid, left rear and left mid).
 - III. Press "RETRACT" or "EXTEND," then "RIGHT" (Fig. 12E) to operate right jacks (right mid and right rear).
 - IV. Press "RETRACT" or "EXTEND," then "LEFT" (FIG. 12F) to operate left jacks (left mid and left rear).

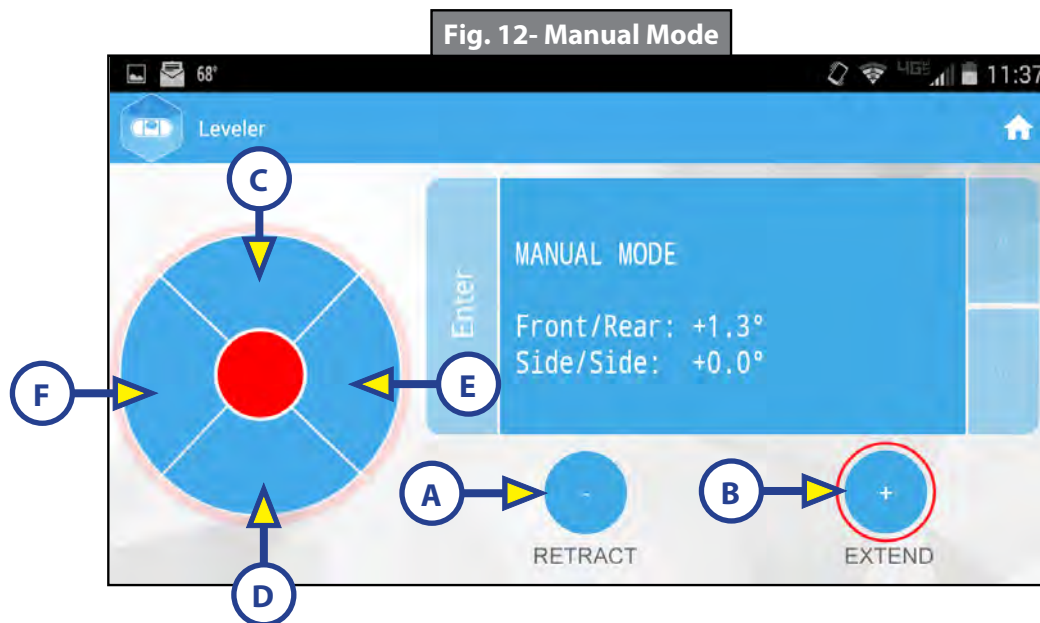

Unhitching Instructions

NOTE: Prior to unhitching from the tow vehicle, ensure trailer is parked on a level surface and chock the tires of the trailer.

1. Push "Extend" (Fig. 10I) and "FRONT" buttons (Fig. 10) to extend front jacks and lift front of trailer to take the weight of the trailer off of the hitch.
2. Uncouple the trailer connection on the tow vehicle.
3. Pull tow vehicle away and park at a safe distance.

Auto Level

NOTE: Once the automatic leveling cycle has been started, it is important that there is no movement in the trailer until the trailer has completed the leveling process. Failure to remain still during the leveling cycle could have an effect on the performance of the leveling system.

1. After unhitching from tow vehicle press "AUTO LEVEL" (Fig. 10J).

NOTE: Pressing "ABORT" during an Auto Level sequence will abort the auto leveling cycle.

Auto Level Sequence

NOTE: Sequence may vary slightly based on the height of the trailer king pin prior to leveling.

1. When the Auto Level sequence begins, the front of the trailer will seek a position near a level state, then the trailer will level from front to back.
2. The left side jack(s) extend to ground (left mid and left rear).
3. The right side jack(s) extend to ground (right mid and right rear).
4. Jack pairs will extend as needed in order to level the trailer.

NOTE: Step 4 may repeat several times if the controller deems necessary.

NOTE: If the AUTO LEVEL sequence does not perform as described above, place the system in manual mode and test that the jacks operate correctly by pushing their coordinating buttons on the touch panel in manual mode, e.g., "FRONT" button operates only the front jacks, etc.

Touch Pad Diagram - Linc Remote Control - Optional

Callout	Description
A	Retract - Retracts front jacks and rear jacks.
B	Extend - Extends front jacks and rear jacks.
C	Help - Provides contact information for Lippert.
D	Front Arrow - Operates front jacks.
E	Left Arrow - Operates left rear jacks.
F	Right Arrow - Operates right rear jacks.
G	Rear Arrow - Operates rear jacks.
H	Auto Level- Initiates Auto Level sequence.
I	Power Button - Turns remote control on and off.

Fig. 13



Configuring Linc Remote to Sync to MyRV One Control Touch Panel

1. Turn on the Linc remote control (Fig. 13I) and enter a PIN.
2. Choose "Leveler" from the menu screen.
3. Turn on the MyRV OneControl Touch Panel (Fig. 2K).
4. On the MyRV OneControl Touch Panel, press the "CONNECTED" icon at the top of the screen (Fig. 14A) quickly 6 times. Wait a few seconds until the gear icon with "OPTIONS" appears (Fig. 15A).
5. Press the gear icon with "OPTIONS" (Fig. 15A).
6. Use the "UP" and "DOWN" arrows (Fig. 15B) to scroll to "WIRELESS CONFIG" (Fig. 16).
7. Press "ENTER" (Fig. 16A). The screen will display "Wireless Configuration Press any Linc button to Sync" (Fig. 17).
8. Press any button in "Leveler" mode on the Linc remote control (Fig 13).
9. Pressing "ABORT" on the MyRV OneControl Touch Panel (Fig. 17A) will cancel configuration sequence.

Fig. 14

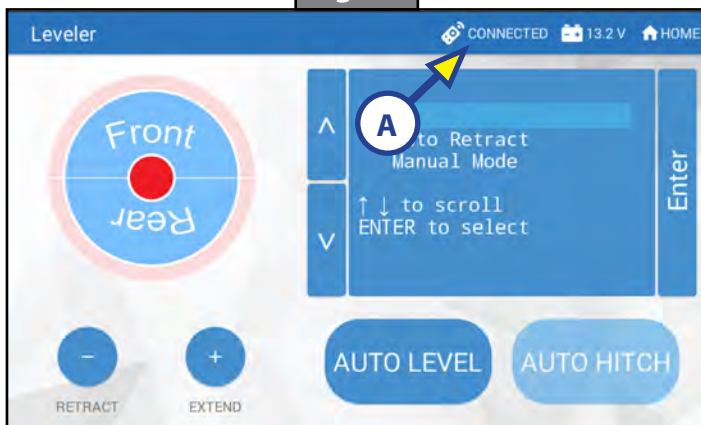

Fig. 15

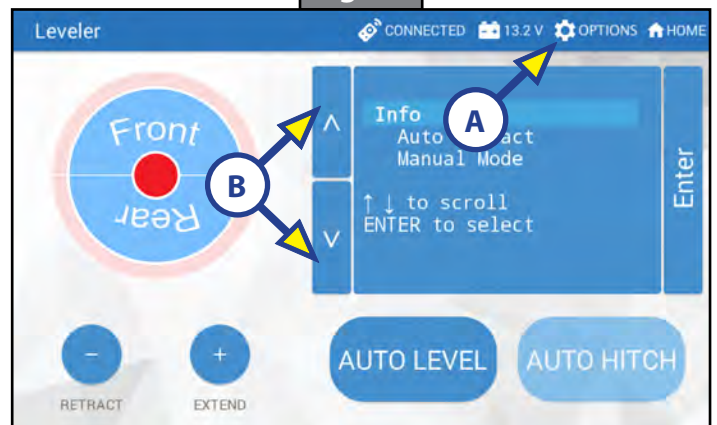

Fig. 16

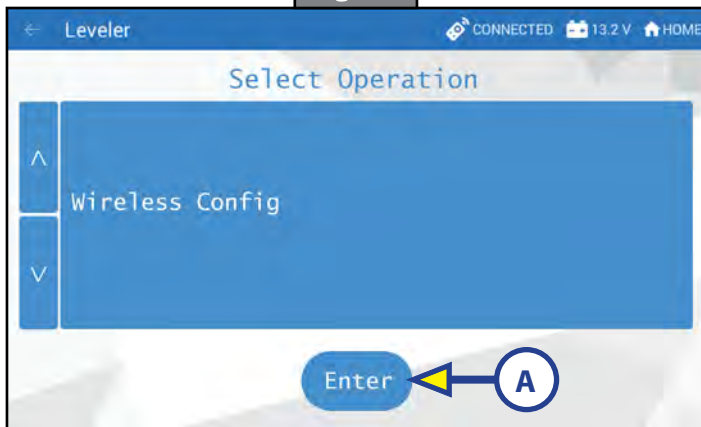
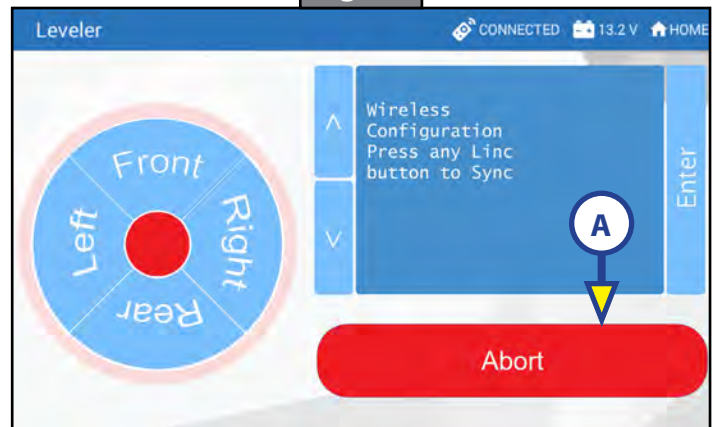

Fig. 17



Basic Jack Operation

1. Press RETRACT (Fig. 13A) or EXTEND (Fig. 13B) and "front" arrow (Fig. 13D) to operate front jacks.
2. Press RETRACT or EXTEND, then "rear" arrow (Fig. 13G) to operate rear jacks (right rear, right mid, left rear and left mid).
3. Press RETRACT or EXTEND, then "right" arrow (Fig. 13F) to operate right jacks (right mid and right rear).
4. Press RETRACT or EXTEND, then "left" arrow (Fig. 13E) to operate left jacks (left mid and left rear).
5. Press AUTO LEVEL (Fig. 13H) to start auto-level sequence.

Unhitching Instructions

NOTE: Prior to unhitching from the tow vehicle, ensure trailer is parked on a level surface and chock the tires of the trailer.

1. Turn the Linc remote on (Fig. 13I) and enter a PIN code to turn system on.
2. Press the LEVELER button.
3. Press EXTEND (Fig. 13B) and FRONT arrow (Fig. 13D) to extend front jacks and lift front of trailer to take the weight of the trailer off of the hitch.
4. Uncouple the trailer connection on the tow vehicle.
5. Pull tow vehicle away and park at a safe distance.

Auto Level

NOTE: Once the automatic leveling cycle has been started, it is important that there is no movement in the trailer until the trailer has completed the leveling process. Failure to remain still during the leveling cycle could have an effect on the performance of the leveling system.

1. After unhitching from the tow vehicle press "AUTO LEVEL" (Fig. 13H).

NOTE: Pressing any button on the Linc™ remote during an Auto Level sequence will abort the auto leveling cycle. To restart the Auto Level process, refer to the OneControl Touch Panel (Fig. 2).

Auto Level Sequence

NOTE: Sequence may vary slightly based on the height of the trailer king pin prior to leveling.

1. When the Auto Level sequence begins, the front of the trailer will seek a position near a level state, then the trailer will level from front to back.
2. The left side jack(s) extend to ground (left mid and left rear).
3. The right side jack(s) extend to ground (right mid and right rear).
4. Jack pairs will extend as needed in order to level the trailer.

NOTE: Step 4 may repeat several times if the controller deems necessary.

NOTE: If the Auto Level sequence does not perform as described above, test that the jacks operate correctly by pushing their coordinating buttons on the Linc remote; e.g., "FRONT" button operates only the front jacks, etc. The jacks can also be tested in manual mode on the OneControl Touch Panel (Fig. 2). See Operation - MyRV OneControl Touch Panel.

Maintenance

Fluid Recommendation

ATF with Dexron III® or Mercon 5® or a blend of both is recommended by Lippert.

Type "A" Automatic Transmission Fluid (ATF) is utilized and approved.

Hydraulic system operation in climates at or below 40 degrees F (4 degrees C) may result in the following:

- Slow operation during extension/retraction
- Incomplete retraction of jacks during Auto Retract procedure

NOTE: A visual inspection of the jacks in the retract position is recommended after completing Auto Retract.

For a list of approved fluid specifications, scan this QR Code or go to: [TI-188 - Hydraulic Operation Fluid Recommendation](#).



Preventative Maintenance

1. Check hydraulic fluid in reservoir every 12 months. If fluid is a clear, red color, do not change. If fluid is milky, pink and murky, and not clear red in color, drain reservoir and add new fluid. Hydraulic fluid in reservoir should be changed a minimum of every five years.

NOTE: Check the fluid only when all the jacks are fully retracted.

NOTE: When checking the hydraulic fluid level, fill to within 1/4" to 1/2" of fill spout.

2. Inspect and clean all power unit electrical connections every 12 months. If corrosion is evident, use a small amount of lubricant to remove corrosion. Contacts must be cleaned with a non-residue cleaner prior to use. Lippert recommends the use of an electrical contact cleaner spray.
3. Remove dirt and road debris from jacks as needed.

⚠ WARNING

The coach should be supported at both front and rear axles with jack stands before working underneath. Failure to do so may result in death, serious personal injury or severe product or property damage.

4. If jacks are down for extended periods, it is recommended to spray exposed jack rods with a dry silicone lubricant every three months for protection. If the trailer is located in a salty environment, it is recommended to spray the rods every four to six weeks.

Manual Override

The Lippert Level Up Automatic Leveling System can be manually operated with an electric drill. In the event of electrical or system failure, this manual method of extending and retracting the jacks can be used. See the instructions below.

NOTE: Unhook the power unit motor from the power source prior to attempting the manual override procedure.

1. Locate the valves that are paired with the front jacks or rear jacks to be manually overridden.
 - A. Front jacks - Valve located on the front jacks (Fig. 18).
 - B. Rear Jacks - Valve located on manifold (Fig. 19).

⚠ CAUTION

DO NOT over-tighten override set screws, as this can damage the valves.

2. Using a $\frac{5}{32}$ " hex wrench, open the valve by turning the manual override set screw clockwise (Fig. 20A).
3. Remove protective label (Fig. 21A) from power unit to reveal the manual override coupler.

⚠ CAUTION

DO NOT use an impact wrench to perform any of the override procedures, as this may damage the motor.

4. Using an electric drill with a $\frac{1}{4}$ " hex bit, insert the hex bit into the manual override coupler to manually operate the Level Up system (Fig. 22).
 - A. Run the drill forward (clockwise) to retract the front jacks or rear jacks (Fig. 22A).
 - B. Run the drill in reverse (counterclockwise) to extend the front jacks or rear jacks (Fig. 22B).
5. Be sure to turn the manual override set screw on the valve (Fig. 23A) back to the counterclockwise position after extending or retracting the front jacks or rear jacks.

Fig. 18

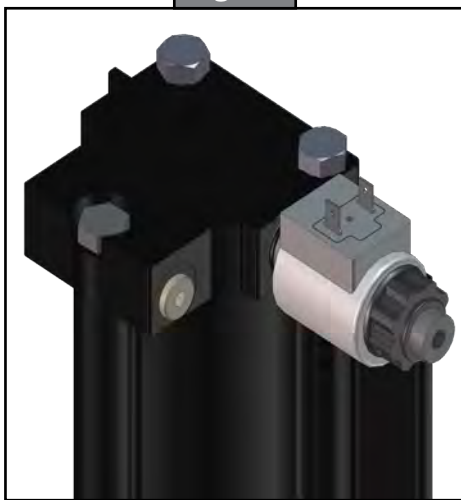

Fig. 19

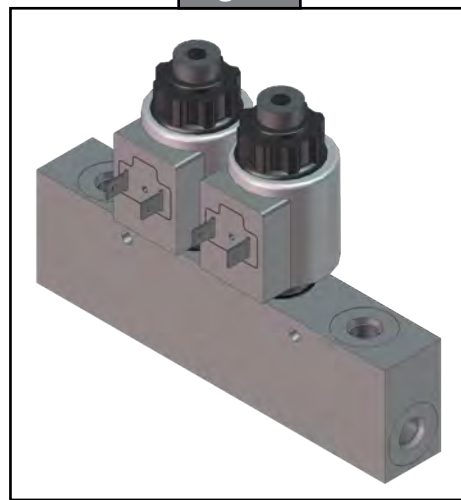

Fig. 20

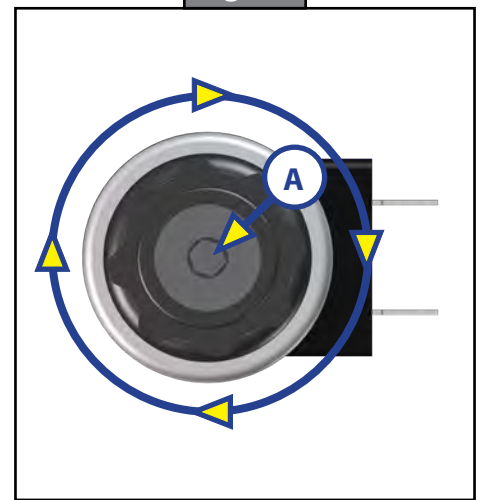

Fig. 21

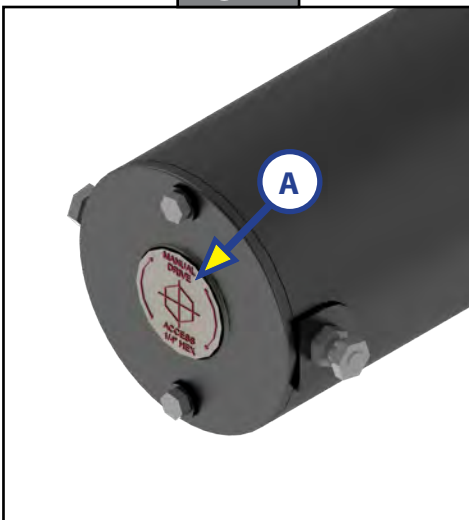

Fig. 22

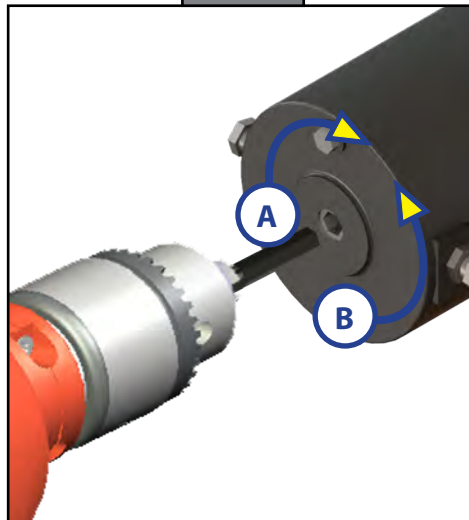
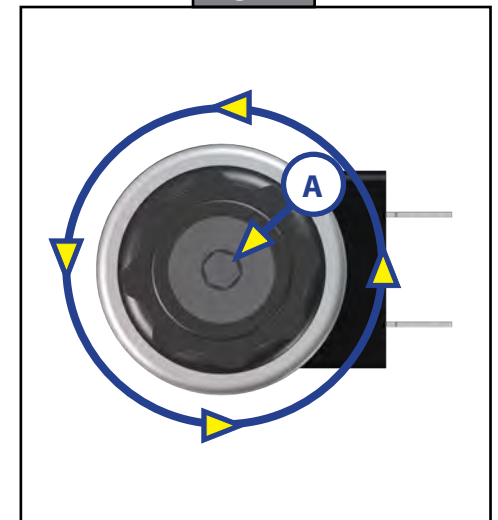

Fig. 23



Troubleshooting

Error Display In LCD Screen

Faults can only be cleared via the OneControl Touch Panel or OneControl Leveling App through MyRV. The only exception is when the Auto Leveling Control mini-touch pad (Fig. 1) was used to abort an auto-sequence. In this case the fault can be cleared by pressing any Auto Leveling Control button.

LCD Message	What's Happening?	What Should Be Done?
"EXCESS ANGLE"	Unsecured controller. Uneven or sloped site.	Check and secure controller placement. Relocate the trailer.
"EXCESSIVE ANGLE"	Controller not properly secured.	Check and secure controller placement.
	Excessive angle reached during manual operation.	Relocate the coach.
"BAD CALIBRATION"	Sensor calibration values are out of range.	Replace controller.
"FEATURE DISABLED"	Hitch recognition requested but no hitch height set.	Perform "AUTO LEVEL" sequence to establish hitch height.
	Zero point not set.	Set zero point.
"LOW VOLTAGE"	Bad connection or wiring. Discharged or bad battery.	Check wiring - repair or replace. Test battery voltage under load - charge or replace.
"OUT OF STROKE"	Unsecured controller. Uneven or sloped site.	Check and secure controller placement. Relocate the trailer.
"EXTERNAL SENSOR"	Bad connection or wiring.	Replace or repair connection to rear remote sensor.
"JACK TIME OUT"	System could not level in expected time.	Check for obstructions, leaks, fluid level and voltage to power unit motor under load.
"AUTO LEVEL FAILURE"	Unsecured controller. Voltage drop.	Check and secure controller placement. Test battery voltage under load - charge or replace.
"FUNCTION ABORTED"	User has aborted an automatic leveling sequence.	Restart the sequence.



**ULTRA LEVEL
MOTORIZED LEVELING
OWNER'S MANUAL**



Scan for product support

TABLE OF CONTENTS

SYSTEM	3
Prior to Operation	3
System Description	3
Features	3
Fluid Recommendation	4
Component Description	4
System Wiring Requirements	4
Air and Auxiliary Features	4
Air and Auxiliary Feature Configuration	5
Miscellaneous	5
Steel Jacks	6
Aluminum Jacks	7
CONTROL PANEL	8
Power Unit Components	9
OPERATION	10
Selecting a Site	10
Level Zero Point Calibration	10
Automatic Leveling Procedure	11
Manual Leveling Procedures	11
Jack Retract Procedures	12
TROUBLESHOOTING	12
Automatic Safety Shutoff	12
Drive Away Protection System	12
Error Mode	12
Manual Override - Jacks	13
Manual Override - Power System	13
"Jacks Down" Alarm	14
User Alarm Mode	14
Low Voltage Signal	14
Fluid Recommendation	14
Preventative Maintenance Procedures	15
Latched Out Warning	15
Troubleshooting Chart	16
PLUMBING DIAGRAM	17
WIRING DIAGRAMS	18

WARNING

Failure to act in accordance with the following may result in death or serious personal injury.

The use of the Ultra Level Leveling System to support the coach for any reason other than that for which it is intended is prohibited by Lippert's limited warranty. The Ultra Level Leveling System is designed as a "leveling" system only and should not be used to provide service for any other reason under the coach such as changing tires or servicing the leveling system.

Lippert Components, Inc. recommends that a trained professional be employed to change the tires on the coach. Any attempts to change tires or perform other services while the coach is supported by the Lippert leveling system could result in damage to the motor home and/or cause death or serious injury.

1. Be sure to park the coach on solid, level ground.
2. Clear all jack landing locations of debris and obstructions.
3. Locations should also be free of depressions.
4. When parking the coach on extremely soft surfaces, utilize load distribution pads under each jack.
5. People and pets should be clear of coach while operating leveling system.
6. Be sure to keep hands and other body parts clear of fluid leaks. Oil leaks in the Lippert Leveling System may be under high pressure and can cause serious skin penetrating injuries.
7. Never lift the coach completely off the ground. Lifting the coach so the wheels are not touching ground will create an unstable and unsafe condition.

Prior to Operation

The leveling system shall only be operated under the following conditions:

1. The coach is parked on a reasonably level surface.
2. The coach "parking brake" is engaged.
3. The coach transmission should be in the neutral or park position.
4. Be sure all persons, pets and property are clear of the coach while Lippert leveling system is in operation.

System Description

Please read and study the operating manual before you operate the leveling system.

The Ultra Level Leveling System is an electric/hydraulic system. A 12V DC electric motor drives a hydraulic pump that moves fluid through a system of hoses, fittings and jacks to level and stabilize the coach.

NOTE: Mechanical portions of the Ultra Level Leveling System are replaceable. Contact Lippert Components, Inc. to obtain replacement parts.

Features

- Automatic extension of jacks from full retract position (with automatic ground detection).
- Automatic leveling of jacks.
- Manual leveling of jacks.
- Automatic retraction of jacks (with automatic full retract detection).
- Air bag suspension features (configurable on/off).
- Emergency retract/User alarm mode (jacks not retracted and park brake disengaged).
- Automatic jack error detection and error mode.

- Configuration mode for Air features.
- Configuration mode for Leveling Zero Point.
- Remote operation.

Fluid Recommendation

ATF with Dexron III® or Mercon 5® or a blend of both is recommended by Lippert. Type "A" Automatic Transmission Fluid (ATF) is utilized and approved.

Hydraulic system operation in climates at or below 40 degrees F (4 degrees C) may result in the following:

- Slow operation during extension/retraction
- Incomplete retraction of jacks during Auto Retract procedure

NOTE: A visual inspection of the jacks in the retract position is recommended after completing Auto Retract.

For a list of approved fluid specifications, scan this QR Code or go to: [TI-188 - Hydraulic Operation Fluid Recommendation](#).



Component Description

The Ultra Level Leveling System consists of the following major components:

- Lippert jacks are rated at a lifting capacity appropriate for your coach. Each jack has a 9" diameter (63.5 Square inch) shoe on a ball swivel for maximum surface contact on all surfaces. (12" Dia. - 113 Sq. In. shoe also available.)
- Each jack is powered from a central 12V DC motor/pump assembly, which also includes the hydraulic oil reservoir tank, control valve manifold, and solenoid valves.
- The Ultra Level Leveling System is controlled electronically from the driver's seat of the coach. The control panel is mounted in the dash. The system can be operated in a manual mode or a fully automatic mode.

System Wiring Requirements

- Battery power (2 ga. SAE J1127. Type SGX).
- Battery ground (2 ga. SAE J1127. Type SGX).
- Logic power (switched via ignition).
- Power brake signal (open=park brake disengaged, GND=park brake engaged).
- 4-wire harness connecting Controller to Touch Panel.
- Jacks status input - switched to GND Jacks not all up - switch closed
Jacks all up – switch open.

Air and Auxiliary Features

(When Applicable)

System has the option to control external Air and Auxiliary features.

When enabled, the feature works according to the following logic:

- Air bag pressure is automatically lowered when starting the auto or manual sequence to maximize lift of jacks.
- An Auxiliary mode is activated when starting an auto retract sequence to fill airbags.
- Auxiliary is active when jacks are all retracted and park brake is disengaged to fill airbags.

Air and Auxiliary Feature Configuration

For Diesel Units with Airbag Suspensions ONLY:

- Feature is entered ONLY after zero mode programming.
- At this point the Wait LED will blink for 20 seconds. You are now in Air/Auxiliary Feature Configuration mode.

To enable Air Auxiliary features, perform the following:

1. Press the Retract All switch 3 times.
2. User must do this within 20 seconds of entering this mode.

To disable Air features, perform the following:

1. Do nothing.
2. After 20 seconds, module will exit mode with features disabled.

Miscellaneous

- The system will automatically shut down after 4 minutes of no operation.
- Auto leveling cycle cannot be started until all jacks are fully retracted. Make sure jacks are retracted before attempting to auto level. (Unit will perform full retract automatically if jacks are not down on the request of an auto cycle.)
- System will refuse any operation when a low voltage condition is present.
- System will automatically alarm and retract if park brake is disengaged and jacks are not retracted with any change in sensor readings. In alarm mode, the only available feature is to retract all jacks.
- Please note the Wait LED shows the status of Air/Auxiliary features.

The LEDs blink differently when in special controller modes (error, alarm and configuration). Learning how to recognize these modes is important. Excess slope LED blinks whenever the Y axis (vehicle length) is over 50 degrees from programmed level point.

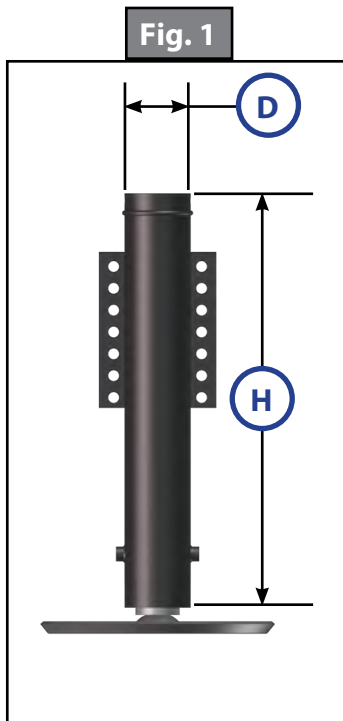

Fig. 1 - 115842
 CAPACITY - 22,000 lb.
 STROKE - 16 in.
 H - 20 ½ in.
 D - 3 ¾ in.
 12" SHOE-STANDARD

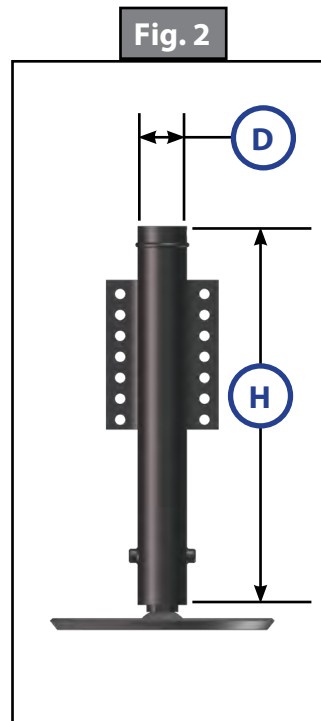

Fig. 2 - 115841
 CAPACITY - 12,000 lb.
 STROKE - 15 in.
 H - 19 ½ in.
 D - 2 ¾ in.
 9" SHOE-STANDARD
 12" SHOE-OPTIONAL

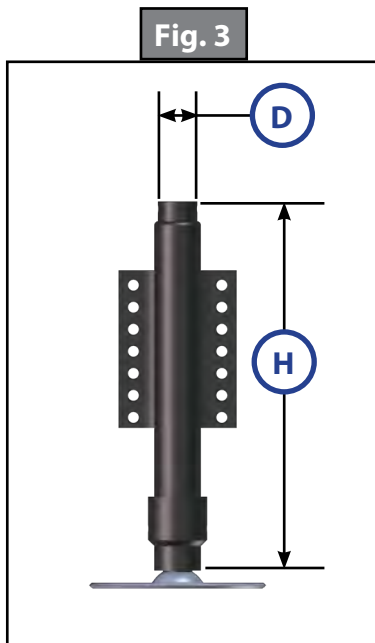

Fig. 3 - 113314
 CAPACITY - 7,000 lb.
 STROKE - 13.75 in.
 H - 18 ¼ in.
 D - 2 ¾ in.
 A - 2 ½ in.
 9" SHOE-STANDARD
 12" SHOE-OPTIONAL

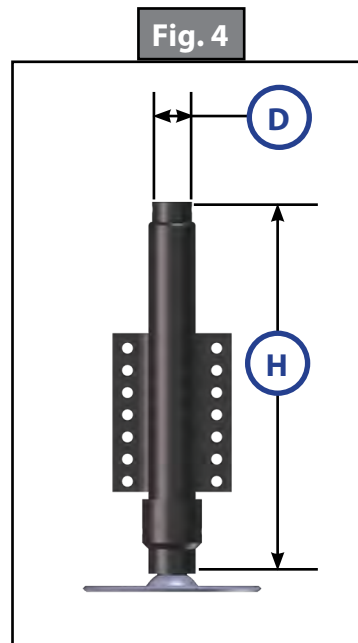

Fig. 4 - 117179
 CAPACITY - 7,000 lb.
 STROKE - 13.75 in.
 H - 18 ¼ in.
 D - 2 ¾ in.
 A - 5 ¾ in.
 9" SHOE-STANDARD
 12" SHOE-OPTIONAL

NOTE: OEM to supply attachment brackets for leveling jacks.

Aluminum Jacks

Fig. 5

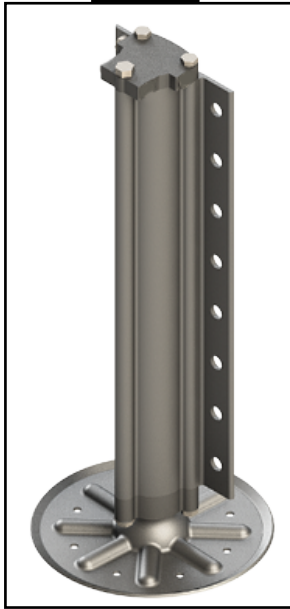

Fig. 5 - 195860

CAPACITY - 8,000 lb.
STROKE - 15 in.
BORE - 2 in.
HEIGHT - 21.375 in.
ROD DIA. - 1.50 in.
9" FOOTPAD-STANDARD
12" FOOTPAD-OPTION - 117238

Fig. 6



Fig. 6 - 236560

CAPACITY - 14,000 lb.
STROKE - 15.13 in.
BORE - 2.50 in.
HEIGHT - 21.50 in.
ROD DIA. - 1.875 in.
9" FOOTPAD-STANDARD
12" FOOTPAD-OPTION - 117238

Fig. 7

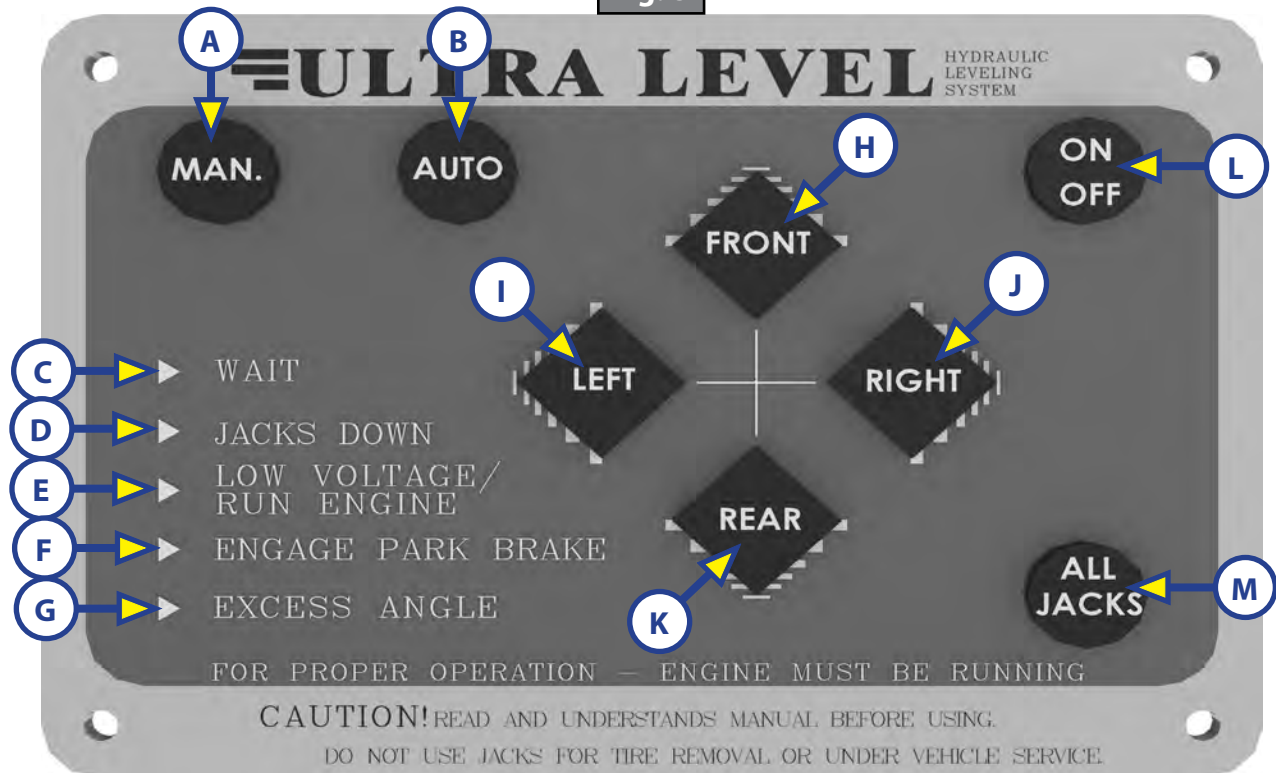

Fig. 7 - 258550

CAPACITY - 20,000 lb.
STROKE - 16 in.
BORE - 3 in.
H - 23.063 in.
ROD DIA. - 2.25 in.
9" FOOTPAD-STANDARD
12" FOOTPAD-OPTION - 117238

Control Panel

Fig. 8



Callout	Description
A	Manual Operation - Places control panel in manual operation mode.
B	Automatic Operation - Places control panel in automatic operation mode.
C	Wait LED - Indicates to the operator to pause operation until the LED turns off.
D	Jacks Down LED - Indicates jacks are not fully retracted.
E	Low Voltage LED - Indicates voltage has dropped below safe operable level. Solid LED indicates voltage is too low to operate system.
F	Engage Park Brake LED - Flashes when park brake is disengaged; off when park brake has been engaged.
G	Excess Angle LED - Coach may not be able to level in current location and must be moved to a more level location.
H	Front Button - Controls operation of both front jacks.
I	Left Button - Controls operation of both left jacks.
J	Right Button - Controls operation of both right jacks.
K	Rear Button - Controls operation of both rear jacks.
L	Power Button - Turns system on and off.
M	Retract All Jacks - Retracts all jacks automatically. See page 12 for retract procedures.

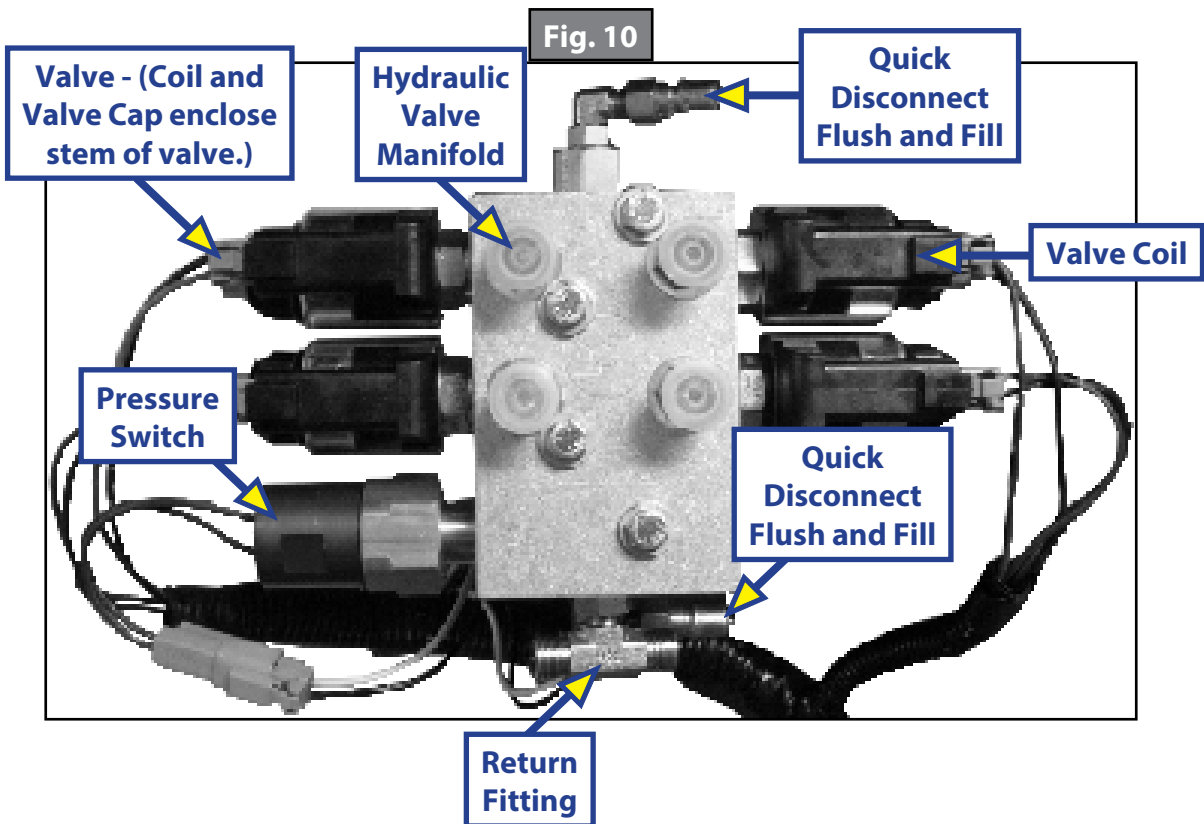
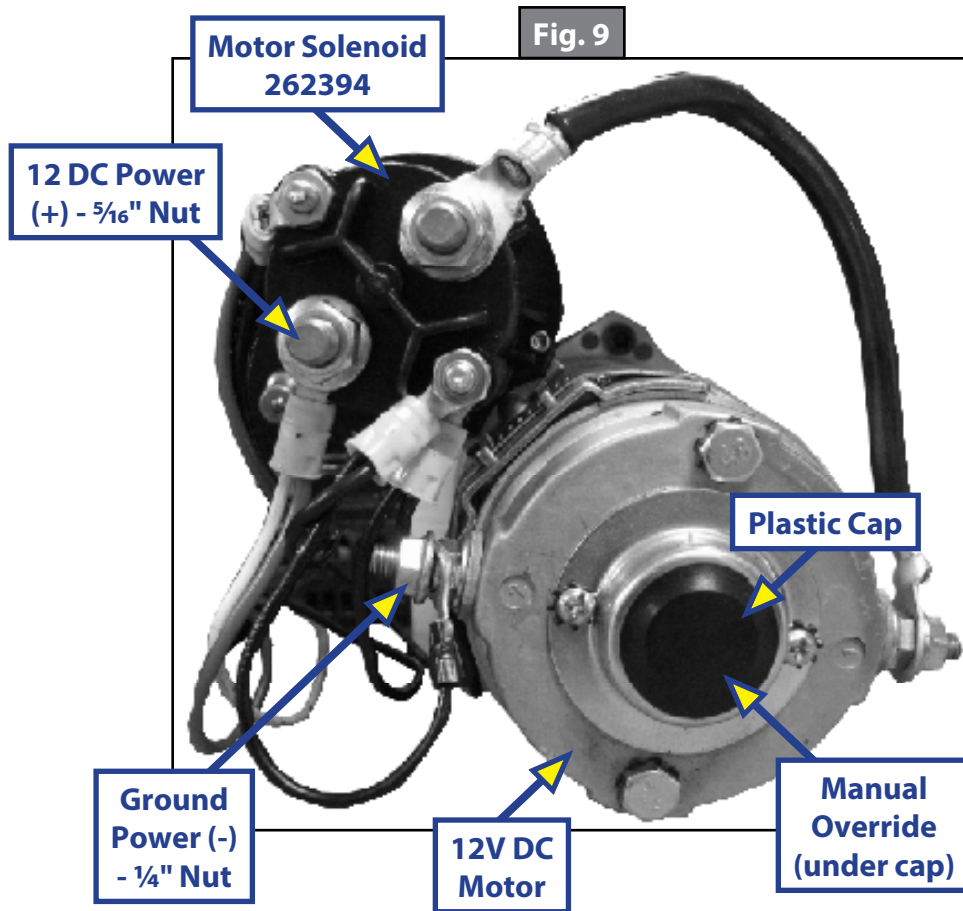

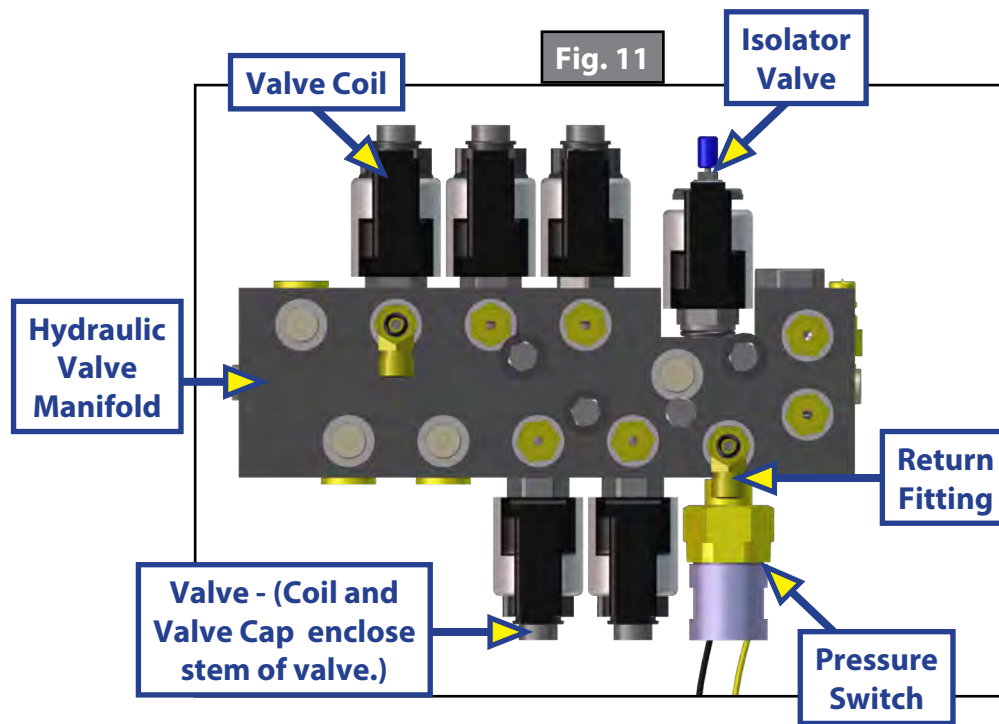

Operation

Selecting a Site

When the coach is parked on an excessive slope, the leveling requirements may exceed the jack lift stroke capability. If the coach is parked on an excessive slope, the coach should be moved to a more level surface before the leveling system is deployed.

Level Zero Point Calibration

Before the auto leveling features are available, the Level Zero Point must be set. This is the point to which the system will return when an auto leveling cycle is initiated. To set the Zero Point (controller module must be fully secured in production-intent location), first run a manual leveling sequence to get the vehicle to the desired level point. Then activate the Level Zero Point configuration mode. This mode is enabled by performing the following sequence.

1. Turn the Touch Pad OFF.
2. Turn the Touch Pad ON and perform the following:
 - A. Press the Front button 5 times.
 - B. Press the Rear button 5 times.

NOTE: At this point all LED outputs will blink. This indicates the system is in the IDLE mode ready to set Zero Point.

3. Press the Retract All button 3 times.

NOTE: All LEDs will go out except the WAIT light. The WAIT light will blink continuously for approximately 20 seconds while the Level Zero Point is being programmed into the controller.

NOTE: For Diesel Units with Automatic Airbag Suspensions ONLY: - Press the Retract All button 3 more times to program the auto dump/auto fill feature for the airbags.

4. The WAIT light will then go off and the LCI logo in the middle will illuminate, indicating a successful programming of the Zero Point configuration.

Automatic Leveling Procedure

NOTE: Refer to Fig. 8 for questions regarding location and functions of the Ultra Level Leveling System.

NOTE: Coach must be running and parking brake must be engaged for Ultra Level Leveling System to operate.

1. Push ON/OFF button on Control Panel. The system is now operational and the electronic level lights will become active.
2. Check to see that the Control Pad ENGAGE PARK BRAKE light is not flashing.
3. Push the AUTO button to begin the automatic leveling cycle.

NOTE: After starting the automatic leveling cycle it is very important that you do not move around in the coach until the unit is level and the green LCI logo light illuminates in the center of the touch pad. Failure to remain still during the leveling cycle could have an affect on the performance of the leveling system.

4. If further adjustments are necessary, refer to the Manual Leveling Procedures section below.

WARNING

Lifting all wheels off the ground may result in death or serious personal injury.

5. Push power button to turn off the system.

Manual Leveling Procedures

NOTE: When leveling your coach, the coach should be leveled from front to rear first (Step 2-4). When the coach is level from front to rear, then level the coach from left to right (Step 5).

NOTE: Coach must be running for Ultra Level Leveling System to operate.

1. Push ON/OFF button on control panel. The system is now operational and the ON/OFF light will be lit.
2. Push and hold MAN button for 5 seconds.
3. Push FRONT button until jacks contact the ground and lift the front of the coach 1-2 inches.
4. Push REAR button until jacks contact the ground and lift rear of coach. Keep button depressed until bubble is centered.
5. Push LEFT or RIGHT button; if bubble is towards left of coach, push RIGHT button; if bubble is towards right of coach push LEFT button. Keep button depressed until bubble is centered in vial.

NOTE: The right and left jacks are used to level the coach side to side. Pushing the LEFT button on the control panel will extend both left jacks. Pushing the RIGHT button on the control panel will extend both right jacks. Jacks always work in pairs, both front jacks; both right side jacks, etc.

6. Repeat steps 2 through 5 if needed.
7. Turn power off to leveling system by pushing ON/OFF button.
8. Visually inspect all jacks to ensure all shoes are touching the ground. Should one of the rear jack shoes not be touching the ground, press the corresponding LEFT or RIGHT rear jack buttons to lower the corresponding jack to the ground.

WARNING

Lifting all wheels off the ground may result in death or serious personal injury.

Jack Retract Procedures

1. Energize the system by pushing ON/OFF button on control panel. The ON/OFF light will be lit.
2. Push the RETRACT ALL JACKS button. All the jacks will start to retract and return to the full retract position. When all jacks return to full retract position the JACKS DOWN light will go out.

NOTE: If you wish to stop the jacks from retracting, turn the system off and back on again by pushing the ON/OFF button twice. Follow steps 1-5 (Manual Leveling Procedures) to re-level the coach.

3. When the JACKS DOWN light goes out, push the ON/OFF button on the Control Panel to de-energize the system. After a brief visual inspection around the coach to verify the jacks are fully retracted, you may proceed to travel.

NOTE: When in the MANUAL mode, if the RETRACT button is pushed the jacks will only retract as long as the RETRACT button is depressed. In AUTOMATIC mode, the RETRACT button need only be pressed once and released for the jacks to fully retract.

Troubleshooting

Automatic Safety Shutoff

If the control panel is left on and inactive for four minutes it will shut off automatically. To reset the system the coach ignition must be turned off, then back on, and the ON/OFF button must again be pushed.

Drive Away Protection System

If the ignition is in the "RUN" position, jacks are down, and the operator releases the parking brake, all indicator lights will flash and the alarm beeper will activate. The system will then automatically retract the jacks until the jacks are fully retracted or the operator resets the parking brake.

The power unit will also operate to keep the jacks retracted in the event the leveling system loses pressure as the coach is being driven.

Error Mode

If any problem is detected with the jacks, the system will enter Error Mode. Error mode may be recognized by the blinking of Left, Center LCI and Right LEDs.

The following errors are detected by this system:

- Jack over current/short circuit.
- Jack under current/ open circuit.
- Jack extending too long (ground not detected after 2 min.).
- Jack retracting too long (fully retracted not detected after 2 min.).
- Out of stroke detection during auto cycle (if enabled).

The user must respond by pressing On/Off switch, which resets operation.

All normal features are disabled in Error Mode.

If panel loses communication with the controller for more than 5 seconds, the panel will blink the Jacks Down, Park Brake and ON/OFF (if included) LEDs.

Manual Override - Jacks

In the event that the jacks will not extend or retract, the valves can be manually overridden by using a $\frac{5}{32}$ " Allen wrench (Pre-2006 model year, see update below) to turn the manual override clockwise on the valve (See Fig. 12). The leveling jacks can then be extended or retracted. Remember to turn the manual override completely counterclockwise (See Fig. 13) until it will no longer turn, to close the valve after the jacks have been completely extended or retracted.

Fig. 12



Clockwise for manual override

Fig. 13



Counter-clockwise for normal operation

Manual Override - Power System

The Ultra Level Leveling System can be run with auxiliary power devices like electric drills, ratchet wrenches or cordless screwdrivers. In the event of electrical or system failure, this manual method of extending and retracting the jacks can be used. A standard handheld drill is all that is required. See the instructions below.

1. Remove plastic cap (Fig 14).
2. Disconnect power cables on the motor.
3. Using a $\frac{1}{2}$ " socket, insert into auxiliary drive device, i.e. cordless or power drill. Insert socket onto coupler found under plastic cap (Fig. 15).

Fig. 14

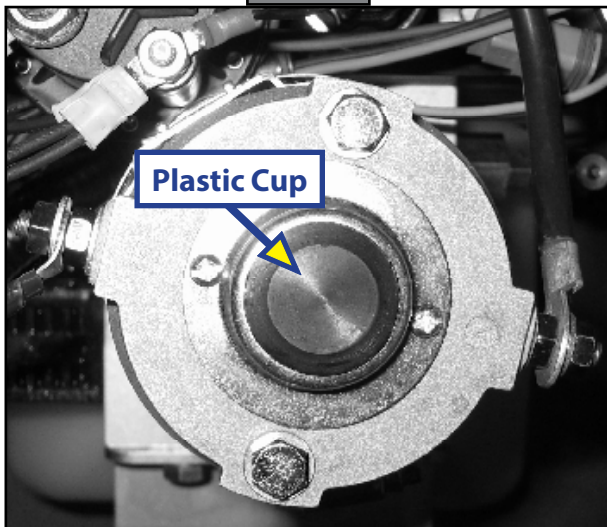
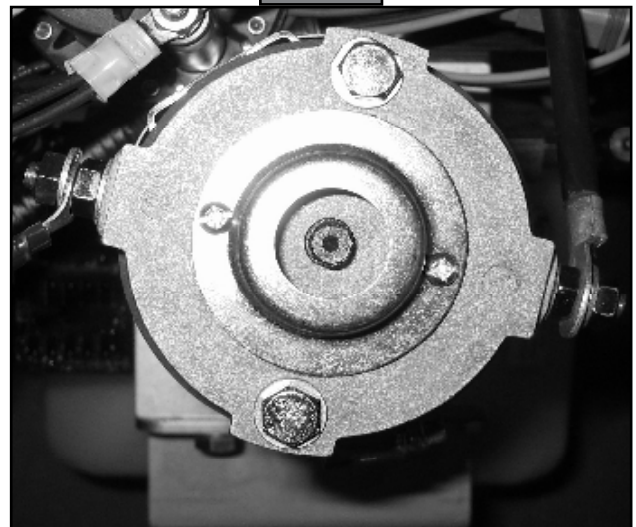

Fig. 15



4. Run drill in reverse or counterclockwise to retract jacks.

"Jacks Down" Alarm

The Ultra Level Leveling System is designed to sound an alarm and illuminate the control panel in the event of two (2) possible scenarios:

- A. A "RETRACT" hose leaks.
- B. The pressure holding the jacks in the retracted position falls to approximately 1500 psi to sound the alarm.

If the alarm sounds and the control panel illuminates and flashes while driving the vehicle:

1. Immediately find an area to safely pull the vehicle off of the roadway.
2. Set the PARKING BRAKE.
3. Inspect all jacks hoses and check valve for leaks.

If no leaks are observed;

1. Turn control panel "ON."
2. Push "RETRACT ALL JACKS" button.
3. Wait until "JACKS DOWN" light and alarm are off.
4. Inspect jacks. If jacks are retracted and no leaks are observed, vehicle can be driven.

If system is leaking or alarm does not subside after applying the above procedure, disconnect wires from pressure switch and proceed immediately to a service center. For prolonged travel to the service center, be sure to stop and check the disposition of the leveling jacks periodically to make sure they are not extending.

User Alarm Mode

If the alarm system detects that the park brake has been disengaged while at least one jack is not fully retracted and the sensor value changes in any axis more than a predefined amount, the panel will signal this error to the user.

When in alarm mode, all LEDs will flash and the buzzer will beep. The status LEDs will show the system status.

The system performs an automatic retract.

No other features are available in this mode.

Low Voltage Signal

If LOW VOLTAGE light is on solid, it is an indication of a charging system problem. Turn ignition OFF and then back ON to reset system. If LOW VOLTAGE light persists, test battery under load at battery and at the motor solenoid on the pump unit. Check all power and ground connections at the battery, alternator and chassis.

Fluid Recommendation

ATF with Dexron III® or Mercon 5® or a blend of both is recommended by Lippert.

Type "A" Automatic Transmission Fluid (ATF) is utilized and approved.

Hydraulic system operation in climates at or below 40 degrees F (4 degrees C) may result in the following:

- Slow operation during extension/retraction
- Incomplete retraction of jacks during Auto Retract procedure

NOTE: A visual inspection of the jacks in the retract position is recommended after completing Auto Retract.

For a list of approved fluid specifications, scan this QR Code or go to: [TI-188 - Hydraulic Operation Fluid Recommendation](#).



Preventative Maintenance Procedures

1. Change fluid in RESERVOIR ONLY when contaminated.
 - A. Check fluid only when jacks are fully retracted.
 - B. Always fill the reservoir with the jacks in the fully retracted position. Filling reservoir when jacks are extended will cause reservoir to overflow into its compartment when jacks are retracted.
 - C. When checking fluid level, fluid should be within ¼" of fill spout lip.
2. Check the fluid level every month.
3. Inspect and clean all Pump Unit electrical connections every 12 months. If corrosion is evident, spray unit with WD-40 or equivalent.
4. Remove dirt and road debris from jacks as needed.

⚠ WARNING

Your coach should be supported at both front and rear axles with jack stands before working underneath. Failure to do so may result in death or personal injury.

5. If jacks are down for extended periods, it is recommended to spray exposed leveling jack rods with a silicone lubricant every three months for protection. If your coach is located in a salty environment, it is recommended to spray the rods every 4 to 6 weeks.

Latched Out Warning

LATCHED ERROR mode is "Wait", "Jacks Down", "Park Brake", "Excess Slope" and "Low Voltage" lights flashing.

1. Battery voltage below 10.0V DC.
2. Retract time over 67 seconds in auto retract.
3. This is the only LATCHED ERROR mode.

To RESET, push all 4 diamond-shaped jack buttons at the same time (Fig. 16).

Fig. 16

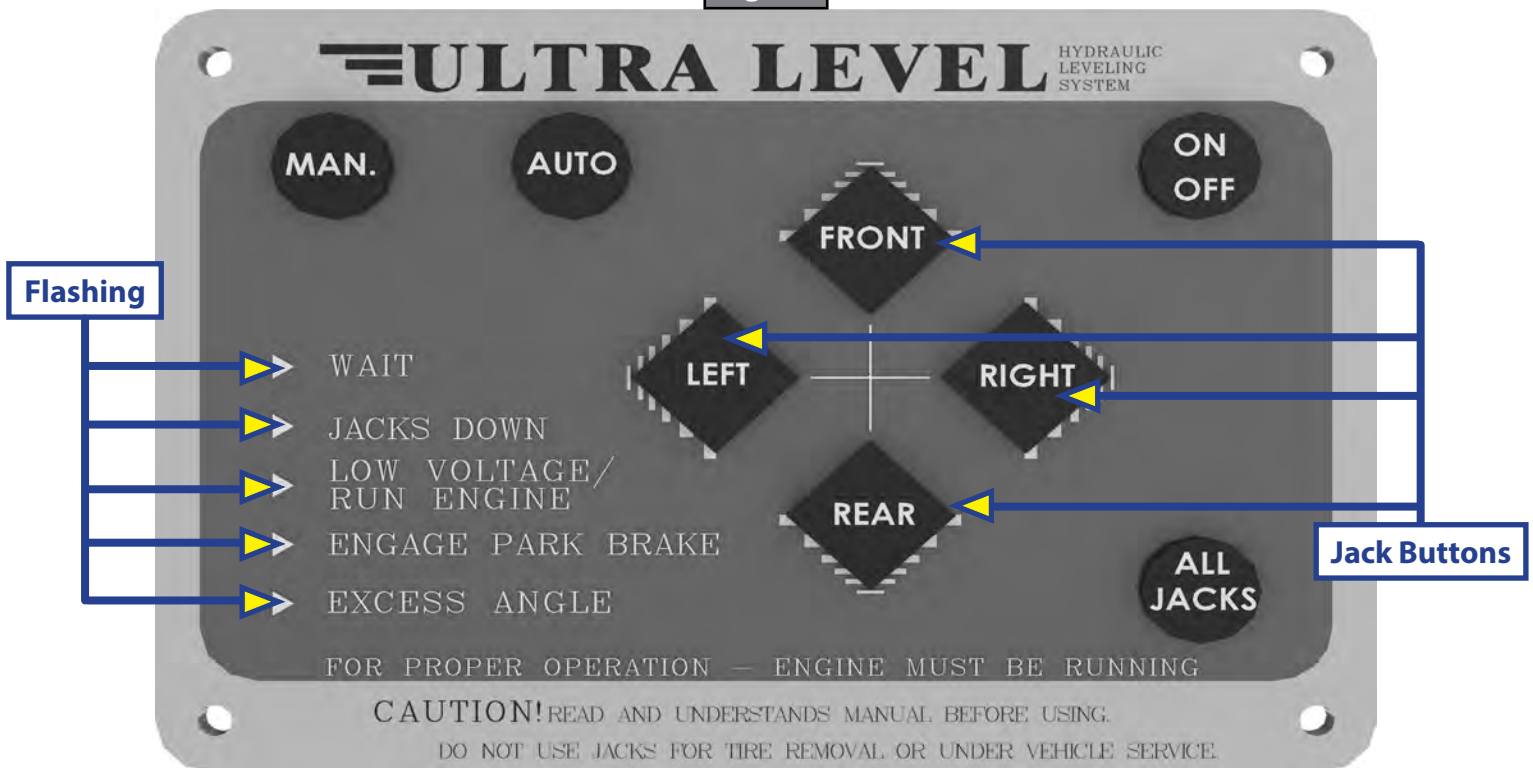

Troubleshooting Chart

What Is Happening?	Why?	What Should Be Done?
System will not turn on and on/off indicator light does not illuminate	Coach ignition not in RUN position	Turn ignition to RUN position
	Parking brake not set	Set parking brake
	Controls have been on for more than four minutes and have timed out	Turn ignition off and then back on
Control pad turns on but turns off when leg button is pushed	Low voltage on battery	Start coach to charge battery
Control pad turns on, coach will not auto-level, jacks down light is on, jacks are retracted	Low fluid level	Check fluid level in reservoir. If fluid is low, add fluid to FILL TO HERE line on reservoir. If JACKS DOWN light remains on call Lippert Service.
Jacks will not extend to ground, pump is running	Little to no fluid in reservoir	Fill reservoir with DEXRON III ATF
	Leg valve is inoperative	Clean, repair or replace
	Electronic signal is lost between control leg valves	Trace wires for voltage drop or loss of signal. Repair or replace necessary wires or replace control pad.
Any one or two jacks will not retract	Hose damaged or unconnected	Replace with new hose or reconnect hose
	Return valve inoperative	Replace inoperative return valve
	Electronic signal is lost between control and solenoid	Attempt to retract jacks in manual mode. If successful, replace control pad. If not, test for voltage drop between control pad and leg valve. Repair bad wiring or replace defective board or valve.
"Jacks Down" LED does not go out when all jacks are retracted	Low fluid level	Fill reservoir to proper level with ATF
	Retract pressure switch inoperable	Check connection or replace
Alarm sounds and "Jacks Down" LED starts flashing while traveling, jacks are fully retracted	Low fluid level	Fill reservoir to proper level with ATF
	Retract pressure switch inoperable	Check connection or replace
Jack bleeds down after being retracted	Manual override valve open	Close override
Control panel powers up; "Low Voltage" LED flashes	Engine not running	Start coach engine
"Low Voltage" LED is solid	Charging system faulty	Turn key OFF then, back ON again to reset. Check power and ground connections on battery, alternator and chassis.
No Power to control panel	Tripped circuit breaker	Reset circuit breaker
	Ignition not on	Turn ignition on

Plumbing Diagram

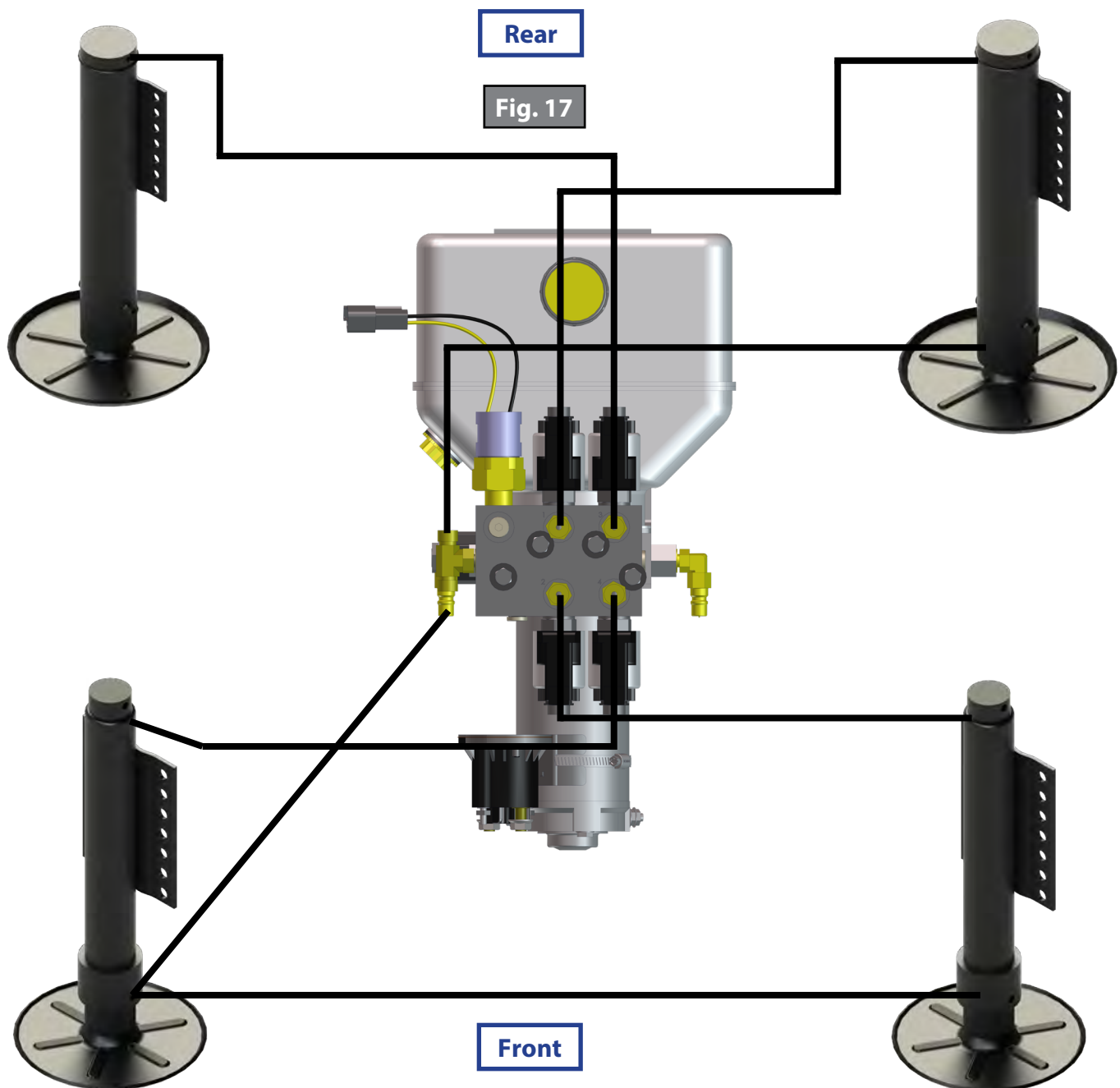

1. Hoses will vary in length by coach model.
2. Measure hose and consult LCI Service. Hose Specs. 3000 p.s.i.; ½" in. I.D.
3. Curbside Front - Black Hose - PURPLE Label & Wire
4. Roadside Front - Black Hose - GREEN Label & Wire
5. Curbside Rear - Black Hose - RED Label & Wire
6. Roadside Rear - Black Hose - BLUE Label & Wire
7. Return - Orange Hose
8. PSI Switch - Yellow Wire into Blue PSI Wire

Fig. 18

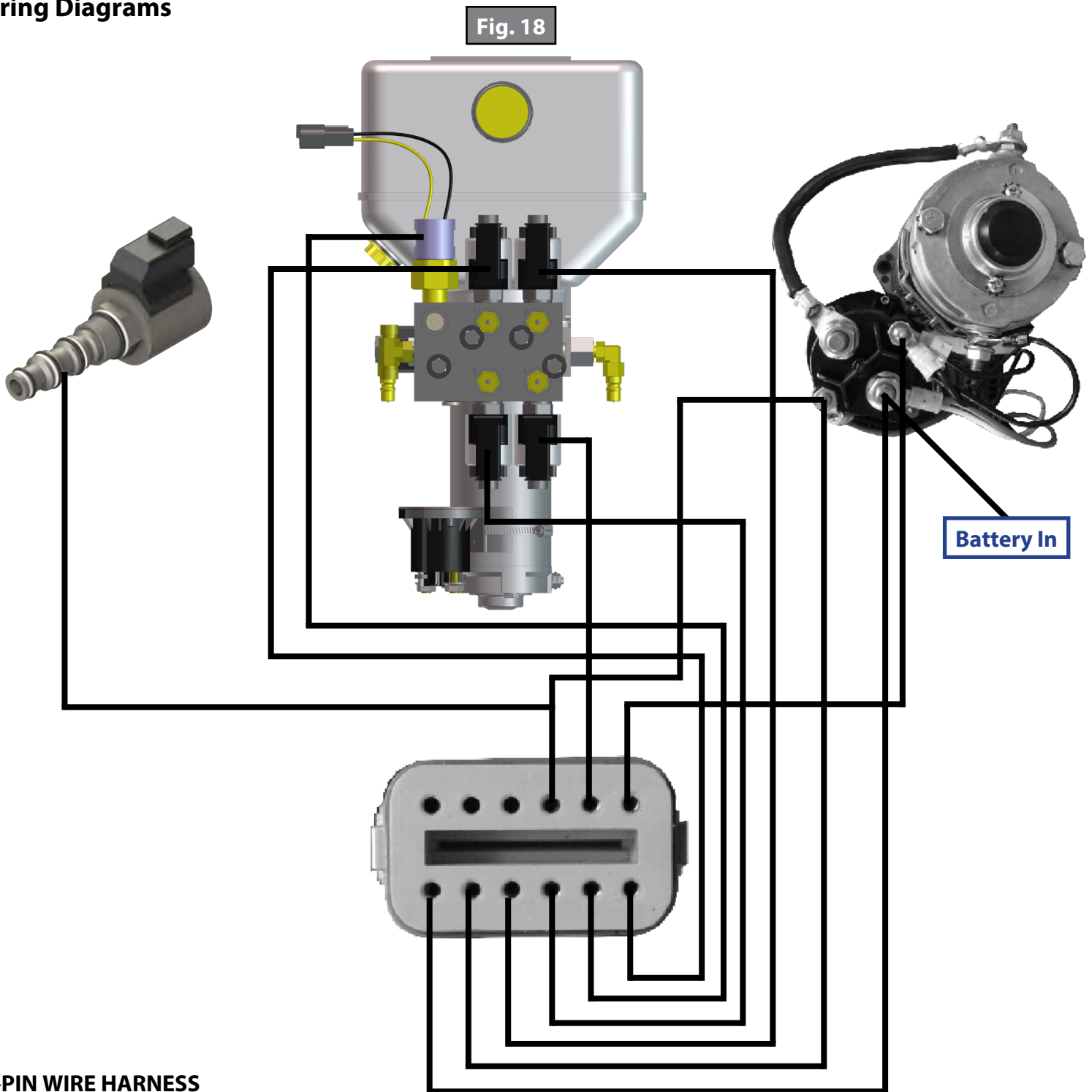

12-PIN WIRE HARNESS

- | | |
|----------------------------------|---------|
| 1. WHITE (CHASSIS POWER) | 10. AUX |
| 2. BLACK W/WHITE (PUMP SOLENOID) | 11. AUX |
| 3. RED (CURBSIDE REAR VALVE) | 12. AUX |
| 4. GREEN (ROADSIDE FRONT VALVE) | |
| 5. YELLOW (PSI SWITCH) | |
| 6. BLUE (ROADSIDE REAR VALVE) | |
| 7. BROWN (GROUND) | |
| 8. PURPLE (CURBSIDE FRONT VALVE) | |
| 9. GREY (PUMP SOLENOID) | |

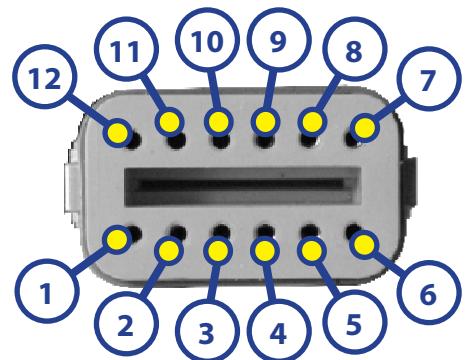
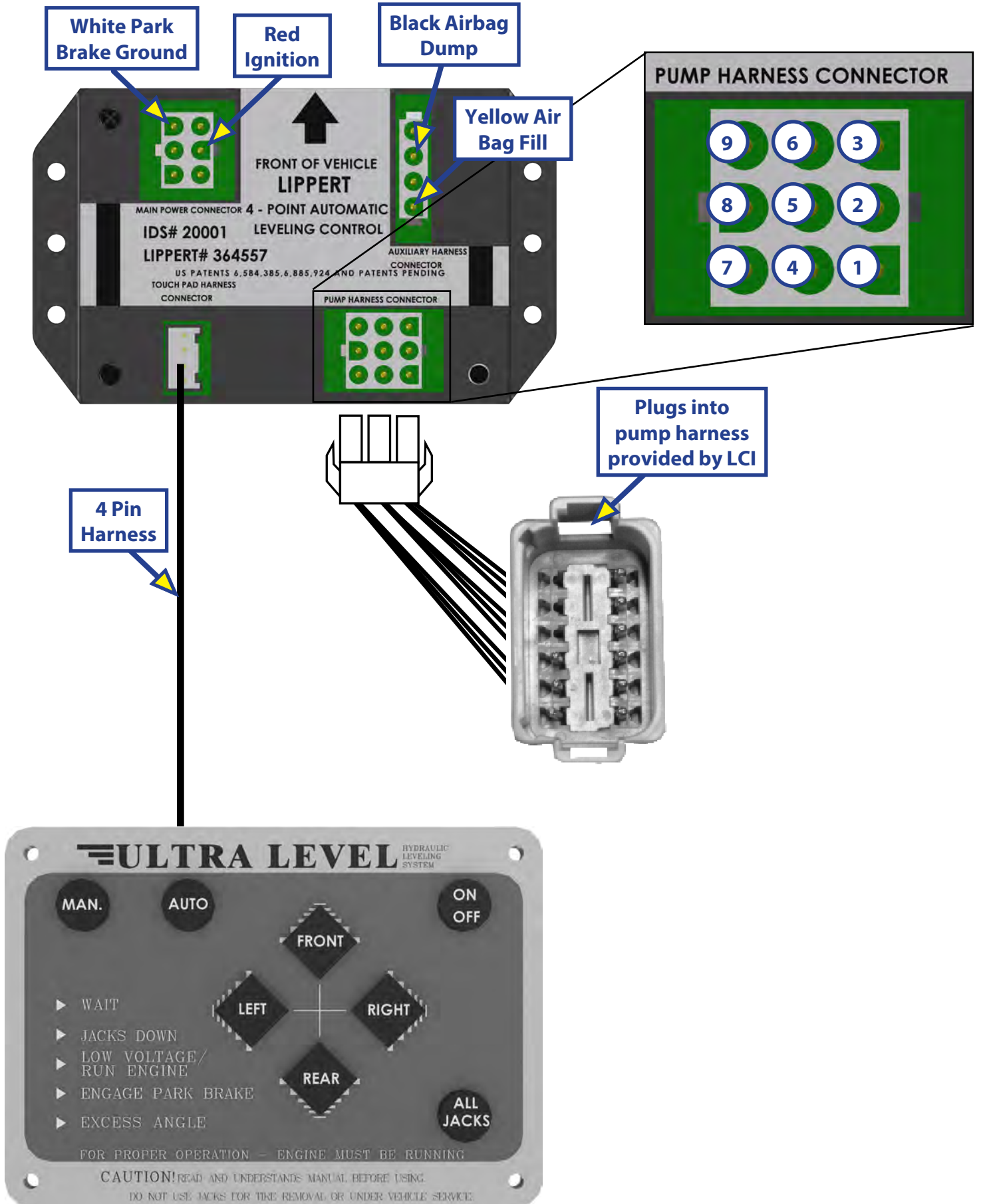

Fig. 19





**HYDRAULIC LEVELING
WITH LCD TOUCHPAD
(4 POINT/3 VALVE MOTORIZED)
OWNER'S MANUAL**



Scan for product support

TABLE OF CONTENTS

Introduction	2
Safety	3
Operation	4
Selecting A Site.....	5
Automatic Leveling Descriptive Logic.....	5
Automatic Leveling Procedure.....	5
Manual Leveling Procedure.....	6
Automatic Jack Retract Procedures.....	6
Manual Jack Retract Procedures.....	7
Troubleshooting	7
Manual Override of The Power System and Jacks.....	7
Automatic Safety Shutoff.....	8
Drive-Away Protection System.....	8
Jacks Up Verification.....	8
Error Mode.....	9
Excess Slope.....	9
User Alarm Mode.....	9
Miscellaneous.....	9
Low Voltage Signal.....	10
Troubleshooting Table.....	10
Zero Point Calibration.....	11
Maintenance	12
Fluid Recommendation.....	12
Purging the Hydraulic System.....	12
Preventative Maintenance.....	12
Wiring Diagram - Overall System	13
Wiring Diagram - Controller and Touchpad (Non-Water Resistant and Water Resistant)	14
Hydraulic Plumbing Diagram (Aluminum Jacks)	15
Hydraulic Plumbing Diagram (Steel Jacks)	16
Notes	17

Introduction

The four-point three-valve hydraulic leveling system is a hydraulic system which includes four points of contact utilizing either steel or aluminum jacks, and a three-valve manifold system. A 12V DC electric motor drives a hydraulic pump that moves fluid through a system of hoses, fittings and jacks, to level and stabilize the coach. Mechanical portions of the hydraulic leveling system are replaceable. Contact Lippert to obtain replacement parts.

The hydraulic leveling system is primed and tested at the factory. However, the system is shipped dry to avoid hazardous material restrictions.

NOTE: This manual replaces the following previously released Lippert manuals: Class C Hydraulic Leveling Owner's Manual (CCD-0001514) dated 07.19.18 and Class C Hydraulic Leveling (Weld-on) Owner's Manual (CCD-0001487) dated 06.20.18. These two manuals were consolidated into this manual.

Additional information about this product can be obtained from lippert.com/support or by downloading the free LippertNOW app. The app is available on Apple App Store® for iPhone® and iPad® and also on Google Play™ for Android™ users.

Apple App Store®, iPhone®, and iPad® are registered trademarks of Apple Inc.
Google Play™ and Android™ are trademarks of Google Inc.

For support information on this product, go to: <https://support.lci1.com/hydraulic-leveling-lcd-br4-point3-valve>

NOTE: Images used in this document are for reference only when assembling, installing and/or operating this product. Actual appearance of provided and/or purchased parts and assemblies may differ.

Component Description

1. Jacks
 - A. 5K steel or 8K aluminum
 - B. Rated at a lifting capacity for the coach
 - C. Standard 9-inch diameter (63.5 square inch) footpad on a ball swivel for maximum surface contact on all surfaces
 - D. Operational powered from a 12V DC motor/pump assembly
2. Motor/Pump Assembly
 - A. 12V DC motor
 - B. Hydraulic fluid reservoir tank
 - C. Control valve manifold
 - D. Solenoid valve
3. System Controls
 - A. Controlled electronically from the touchpad
 - B. Touchpad can be operated in manual mode or fully automatic mode
4. Fittings and Hoses
 - A. Fittings - High pressure O-Ring Face or J.I.C. - Size 4
 - B. Hose - 1/4" I.D., 3000 psi - W.P. Rated

Safety

Please read and study the operating manual before operating the leveling system.

WARNING

The "WARNING" symbol above is a sign that a procedure has a safety risk involved and may cause death or serious personal injury if not performed safely and within the parameters set forth in this manual.

WARNING

During servicing make sure that the coach is supported according to the manufacturer's recommendation. Lift the coach by the frame and never the axle or suspension. Do not go under the coach unless it is properly supported. Unsupported coaches can fall causing death or personal injury or product or property damage.

WARNING

Failure to act in accordance with the following may result in serious personal injury or death.

CAUTION

The "CAUTION" symbol above is a sign that a safety risk is involved and may cause personal injury and/or product or property damage if not safely adhered to and within the parameters set forth in this manual.

CAUTION

Moving parts can pinch, crush, or cut. Keep clear and use caution

The use of the Lippert Hydraulic Leveling System to support the coach for any reason other than which it is intended, is prohibited by the Lippert Limited Warranty. The Hydraulic Leveling System is designed as a leveling system only and should not be used for any reason to provide service under the coach, e.g. changing tires or servicing the leveling system.

Lippert recommends that a trained professional be employed to change the tires on the coach. Any attempts to change tires or perform other service while the coach is supported by the hydraulic leveling system could result in damage to the coach and/or cause serious injury or death.

Operation

NOTE: It is recommended that the engine idle to maintain the minimum required voltage of 12.75V DC.

The leveling system should only be operated under the following conditions:

1. The coach is parked on a reasonably level surface.
2. The coach parking brake is engaged.
3. The coach transmission should be in the park position.
4. Make sure all people, pets and property are clear of the coach while the hydraulic leveling system is in operation.

⚠ CAUTION

After starting the automatic leveling cycle it is very important to not move around in the coach until the coach is level and the green LED light illuminates in the center of the touchpad. Failure to remain still during the leveling cycle could have an effect on the performance of the leveling system.

Fig. 1

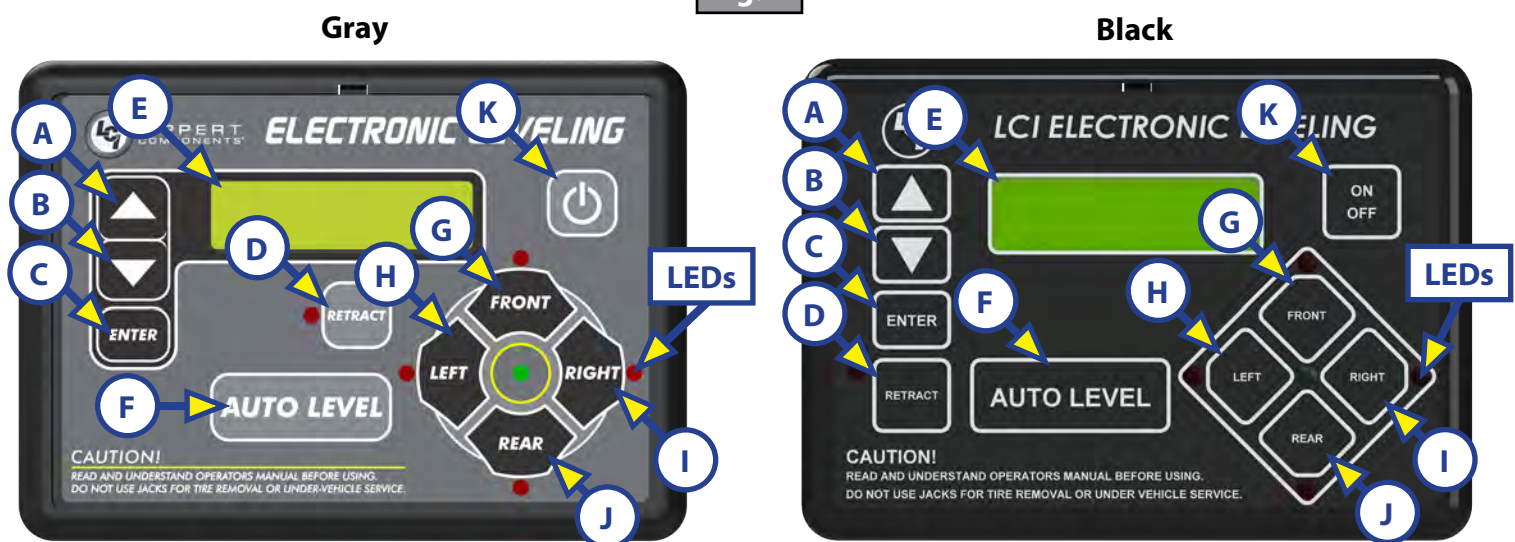

NOTE: Coaches manufactured before January 2018 will utilize the black touchpad.

Callout	Description
A	Up Arrow (UP) - Scrolls up through the menu on LCD.
B	Down Arrow (DOWN) - Scrolls down through the menu on LCD.
C	ENTER - Activates modes and procedures indicated on LCD.
D	RETRACT- Places leveling system into retract mode. — Manual mode ONLY Press and hold for several seconds to activate Auto Retract Function.
E	LCD Display - Displays procedures and results.
F	AUTO LEVEL - Places leveling system into auto level mode.
G	FRONT Jack Button - Activates both front jacks in manual mode.
H	LEFT Jack Button - Activates left rear jack in manual mode.
I	RIGHT Jack Button - Activates right rear jack in manual mode.
J	REAR Jack Button - Activates both rear jacks in manual mode.
K	Power Button - Turns leveling system on and off.

Selecting A Site

When the coach is parked on an excessive slope, the leveling requirements may exceed the jack lift stroke capability. If the coach is parked on an excessive slope, the coach should be moved to a more level surface before the leveling system is deployed. "EXCESS ANGLE" will appear on the LCD screen if the coach is 3.5 degrees out of level front-to-rear or side-to-side.

⚠ WARNING

While utilizing leveling blocks and jack pads, all coach wheels MUST not leave the ground during leveling. Lifting all the wheels off the ground creates a condition where severe property damage, serious personal injury or possible death may occur.

Automatic Leveling Descriptive Logic

Grounding: The following steps describe the process of how the auto-leveling sequence extends the jacks to the ground:

1. Depending on which end of the coach is lowest to the ground, the level sensor in the controller will activate the jacks — the lowest end first, either front or rear.
 - A. If the rear of the coach is the lowest end, ground the lowest rear jack first.
 - B. If the front end is the lowest end, ground the front jack closest to the power unit.
2. Ground the lowest remaining front or rear end jack.
3. Lift lowest end jacks together until level.
4. The leveling system will then ground remaining end jacks.
 - A. If the rear of the coach is the remaining end, ground lowest jack first.
 - B. If the front of the coach is the remaining end, ground the front jack closest to the power unit.
5. Ground the remaining front or rear remaining end jack.
6. Lift remaining end jacks together until level.

Leveling: The following steps describe the process of how the auto-leveling sequence levels the coach once the jacks have been grounded. This process may repeat several times until level.

1. Front-to-rear
2. Side-to-side
3. Individually
4. Minor adjustments to confirm grounding

Automatic Leveling Procedure

NOTE: Coach requires 12.75V DC to commence auto-leveling function.

NOTE: Refer to Component Description listing in the System Information section for questions regarding component locations and functions of the hydraulic leveling system.

NOTE: The engine MUST be running and the parking brake MUST be engaged for the hydraulic leveling system to operate.

NOTE: Pressing any button during an automatic sequence will stop the sequence and a "Function Aborted" error code will occur. Press ENTER to clear the code and then continue the operation or start a new function.

1. Press Power Button to turn system on (Fig. 1K). The green light will illuminate.
2. Press Auto Level (Fig. 1F). LCD Screen will display "Remain Still."
3. The coach will level automatically and indicate "Auto Level - Success" in the LCD display (Fig. 1E).

NOTE: Display will then read "Level - Jacks: Down." Do not press any buttons until this message appears or a "Function Aborted" error will be displayed.

4. Visually inspect all jacks to make sure all footpads are touching the ground. If either of the rear jack footpads is not touching the ground, press LEFT or RIGHT (Fig. 1H or Fig. 1I) to lower the non-compliant jack to the ground.

Manual Leveling Procedure

NOTE: The coach should be leveled front-to-rear first and then leveled side-to-side.

NOTE: The engine **MUST** be running and the parking brake **MUST** be engaged for the hydraulic leveling system to operate.

NOTE: Performing manual leveling on a coach requires a minimum of 9.5V DC.

1. Press Power Button (Fig. 1K) to turn system on.
2. Press the Up Arrow (Up) or the Down Arrow (Down) (Fig. 1A or Fig. 1B) to scroll through control features until "Manual Mode" is displayed.
3. Press Enter (Fig. 1C).
4. Press Front (Fig. 1G) to extend front jacks to the ground.
5. Press Rear (Fig. 1J) to extend rear jacks to ground, then level the coach front-to-back.
6. Press appropriate Left or Right to level the coach side-to-side.

NOTE: Red lights next to the buttons on touchpad will indicate which side(s) of the coach needs to be raised to achieve level condition.

NOTE: The front jacks will work in pairs, i.e., FRONT operates both front jacks.

NOTE: The right and left rear jacks are used to level the coach side-to-side. Pressing LEFT (Fig. 1H) will extend the left rear jack. Pressing RIGHT (Fig. 1I) on the touchpad will extend the right rear jack.

7. Repeat steps 4-6 as needed.
8. Turn off power to leveling system by pressing the Power Button (Fig. 1K).
9. Visually inspect all jacks to make sure all footpads are touching the ground. If either of the rear jack footpads is not touching the ground, press LEFT or RIGHT (Fig. 1H or Fig. 1I) to lower the non-compliant jack to the ground.

Automatic Jack Retract Procedures

NOTE: Pressing any button during an automatic sequence will stop the sequence and a "Function Aborted" error code will occur. Press ENTER to clear the code and then continue the operation or start a new function.

1. Energize the system by pressing the Power Button (Fig. 1K) on the touchpad. The LCD screen will display "READY Jacks: Down."
2. Press Up Arrow (UP) or Down Arrow (DOWN) (Fig. 1A or Fig. 1B) to display "Auto Retract All" on the screen.
3. Press ENTER (Fig. 1C) to begin.

NOTE: "AUTO RETRACT" can also be commenced by pressing and holding RETRACT (Fig. 1D) for one second.

4. The jacks will retract and shut off automatically.
 - A. The display will read "READY - Jacks: Up."
 - B. Press the Power Button (Fig. 1K) on the touchpad to de-energize the system.
 - C. Perform a brief visual inspection around the coach to verify the jacks are fully retracted.

Manual Jack Retract Procedures

To retract in MANUAL mode, do as follows:

⚠ WARNING

All coach wheels MUST NOT leave the ground during leveling. Lifting all the wheels off of the ground creates a condition where severe property damage, serious personal injury or possible death may occur.

1. Press RETRACT (Fig. 1D) until green indicator light comes on.
2. Pressing FRONT or REAR (Fig. 1G or Fig. 1J) will operate the respective jacks in pairs.
3. Pressing RIGHT (Fig. 1I) will operate the right rear jack.
4. Pressing LEFT (Fig. 1H) will operate the left rear jack.

Troubleshooting

⚠ CAUTION

Make sure all jacks are fully retracted before travel.

Manual Override of The Power System and Jacks

In the event that the jacks do not retract, the cartridge valves can be manually overridden.

NOTE: Cartridge valves should be opened prior to operating with any auxiliary power device.

The hydraulic leveling system can be operated in conjunction with auxiliary power devices, like cordless or power drills. In the event of electrical or system failure, the manual method of retracting the jacks can be used. A standard hand-held drill is all that is required.

⚠ CAUTION

Do not over-tighten override set screws as this can damage the valves.

1. Use a $\frac{5}{32}$ " hex key to turn the manual override clockwise (Fig. 2) on each of the three cartridge valves to open the valves.
2. Disconnect or shield power cables on the motor.
3. Remove plastic cap (Fig. 3A) from motor coupler.
4. Unplug the wire harness from the directional valve. See Wiring Diagram.

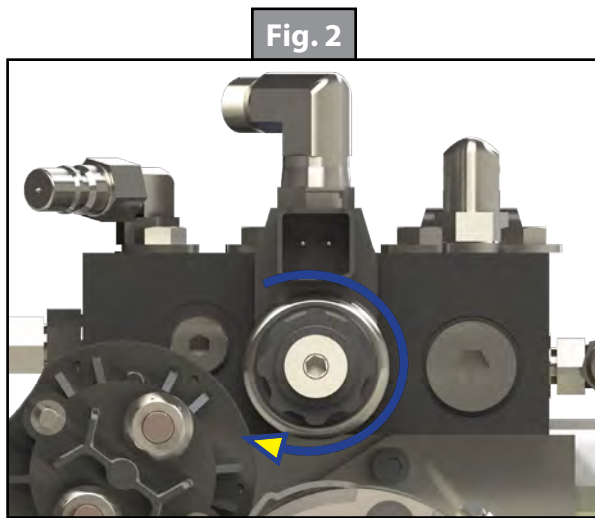

Clockwise for Manual Override

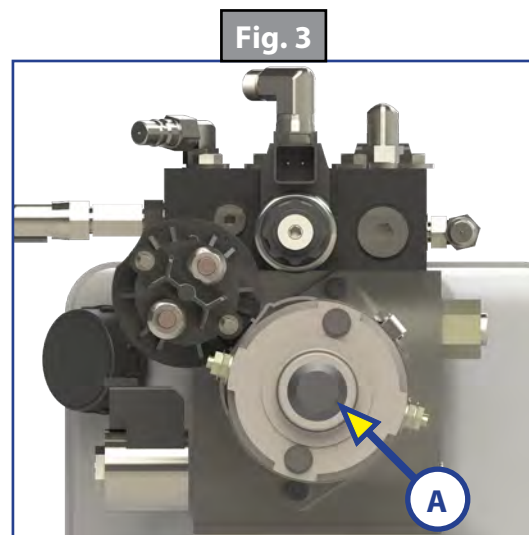

5. Using a 1/2" socket and auxiliary drive device, e.g. cordless or power drill, insert 1/2" socket onto coupler (Fig. 4A).
6. Run drill in reverse, or counterclockwise direction, to simultaneously retract all jacks.
7. After all jacks have been retracted, turn all manual overrides on the cartridge valves counterclockwise (Fig. 5).
8. Reinsert previously removed protective plastic motor coupler cap.
9. Re-attach previously unplugged wire harness to directional valve.

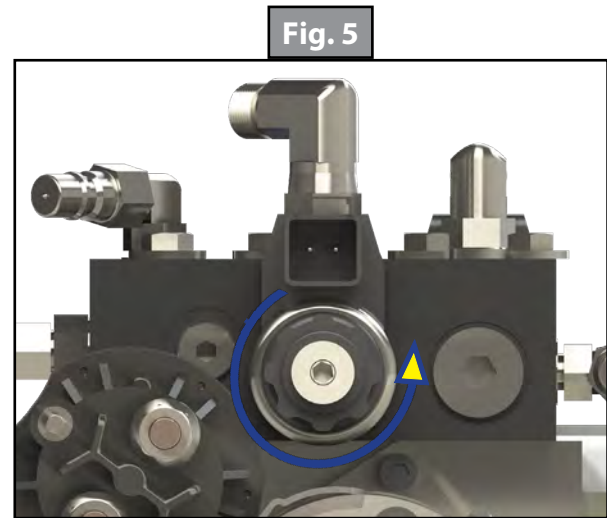
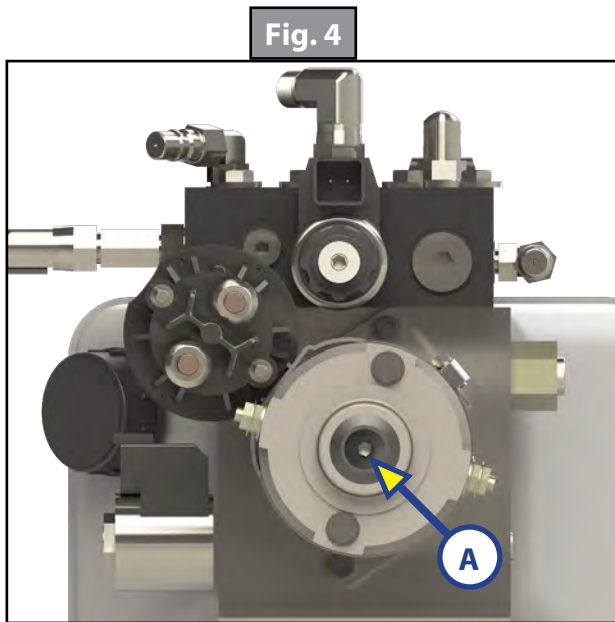

Counterclockwise for Normal Operation

Automatic Safety Shutoff

The touchpad will automatically shutoff after four minutes, if left inactive. To reset the system, turn the coach's ignition off, then back on. Press the touchpad's Power Button (Fig. 1K) again.

Drive-Away Protection System

If the ignition is in the "RUN" position, jacks are extended and the operator releases the parking brake, all indicator lights will flash and the alarm beeper will activate. The leveling system will automatically fully retract the jacks to clear the alarm or, if the operator resets the parking brake, the alarm will shut off.

Jacks Up Verification

If the coach's ignition is in the "RUN" position, the parking brake is released and the vehicle is in motion, the leveling system may activate the power unit to ensure retract pressure is high enough to keep jacks fully retracted. The LCD screen will say "JACKS UP VERIFICATION" until the retract pressure returns to normal level. The touchpad will shut off. No beeping will occur and the "JACKS DOWN" dash light will not illuminate.

Error Mode

1. If an error occurs before or during operation, the error will be displayed in the touchpad's LCD screen (Fig. 1E) and an alarm will sound. To reset common ERROR displays, press ENTER (Fig. 1C).
NOTE: To reset "Return for Service" errors, press ENTER (Fig. 1C) and RETRACT (Fig. 1D) simultaneously. Refer to Error Code Chart for additional error codes.
2. All normal functions will be disabled while the system is in Error Mode.

Error Code Chart		
LCD Display	What is Happening?	What Should Be Done?
Excess Angle	Coach not parked on level ground. Zero point incorrectly calibrated.	Move coach to level ground prior to starting auto level sequence. Recalibrate Zero Point.
Excessive Angle	Occurs only in manual mode when the angle of the coach is too severe.	Use the manual functions to return coach to a more level condition.
Out of Stroke	Jack has insufficient length to complete the leveling procedure.	Check the disposition of the jack.
Low Voltage	Battery voltage dropped below 9.5V DC during operation.	Turn engine on, check battery voltage under load.
Function Aborted	A button was pressed on touchpad during Auto Level operation.	Hit enter to acknowledge. Restart procedure.
Unable to Finish Leveling	Excessive movement inside coach during auto level sequence.	Discontinue movement inside coach during auto level sequence.
Engage Park Brake	Parking brake not set prior to starting auto level sequence.	Set parking brake prior to starting auto level sequence.
Comm Error Check Wiring NOTE: Screen will not back light.	Wiring connections loose or faulty between touchpad and controller.	Check connections, replace communication harness if necessary.
Retract Timeout Return Levelers for Service	Pressure switch did not sense retract pressure and pump timed out. Leaking hose or fitting.	Return levelers for service. Check for leaks, repair if necessary. Press enter and retract to clear error.

Excess Slope

1. The control will not operate at extreme slopes, i.e. 3.5 degrees front and rear and 3.5 degrees side-to-side.
2. If the coach's display indicates "Excess Angle" or "Out of Stroke " during an auto-level cycle, move the coach to a level spot.

User Alarm Mode

If the alarm system detects that the park brake has been disengaged while at least one jack is not fully retracted, the touchpad will buzz and the LED will signal a park break error to the user. The system will then perform an automatic retract sequence. No other features are available in this mode.

Miscellaneous

1. A "Re-Level" feature is programmed into the controller. If the jacks are extended and the user presses AUTO LEVEL (Fig.1F), the system will re-level from that point. The system will not retract before performing the re-level.
2. System will refuse any operation when a low voltage condition is present.

Low Voltage Signal

1. The vehicle requires 12.75V DC to operate in the AUTO mode. If the voltage is too low, the screen will display "Low Voltage."
2. Minimum Voltage - If voltage drops below 9.5V DC during AUTO or MANUAL operation, "Low Voltage" will appear in the screen and the system will cease operating.

NOTE: Coach will operate in manual mode between 9.5V DC and 12.75V DC.

Troubleshooting Table

What Is Happening?	Why?	What Should Be Done?
System will not turn on and the on/off indicator light does not illuminate.	Coach ignition is not in RUN position.	Turn ignition to RUN position.
	Touchpad has been on, but inactive for more than four minutes and has timed out.	Turn ignition OFF and then back ON.
Touchpad turns on, but turns off when jack directional buttons are pressed or touchpad displays "low voltage."	Tripped or blown circuit protection.	Reset or replace circuit protection.
	Low voltage on battery.	Start coach to charge battery.
Touchpad turns on, coach will not auto-level, "Jacks Down" displayed, jacks are retracted.	Low fluid level.	Check fluid level in reservoir. Fluid is low, with jacks retracted, add fluid to 1/2" from top of reservoir. If "Jacks Down" light remains on, call Lippert Customer Service.
Jacks will not extend to ground while pump is running.	Little or no fluid in reservoir.	Add fluid as recommended.
	Cartridge valve is inoperative.	Clean, repair, or replace cartridge valve.
	Electronic signal is lost between controller and coil.	Trace wires for voltage drop or loss, or no valve signals. Repair or replace necessary wires or replace control pad.
Any one or two jacks will not retract.	Hose damaged or unconnected.	Replace with new hose or reconnect hose.
	Cartridge valve is inoperative.	Replace inoperative cartridge valve.
	Electronic signal is lost between controller and coil.	Attempt to retract jacks in MANUAL mode. If successful, replace touchpad; if not, test for voltage drop between touchpad and coil, repair bad wiring or replace defective controller or cartridge valve.
"READY - Jacks: Up" does not display when all jacks are retracted.	Low fluid level.	Add fluid as recommended.
	Retract pressure switch inoperable.	Check connection or replace pressure switch.
Alarm sounds and "Jacks Down" light starts flashing while traveling; jacks are fully retracted.	Low fluid level.	Add fluid as recommended.
	Retract pressure switch inoperable.	Check connection or replace pressure switch.

What Is Happening?	Why?	What Should Be Done?
Coach bleeds down after jacks are extended. Jack bleeds down after being retracted.	Possible fluid leak.	Check for fluid leaks and repair or replace components as necessary.
	Cartridge valve manual override open.	Close override, see Manual Override of The Power System and Jacks.
Touchpad powers up; screen displays "low voltage."	Loose ground wire at power unit.	Check for loose wires.
	Engine not running.	Start coach engine.
No power to touchpad.	Tripped or blown circuit protection.	Reset or replace circuit protection.
	Ignition not ON.	Turn ignition ON.
Auto level function does not finish.	Error code "Unable to finish leveling."	Move coach to a level site.

Zero Point Calibration

Before auto-leveling features are available, the Zero Point MUST be set. This is the point the system will return to when an auto-leveling cycle is initiated. The Zero Point calibration has been set by the RV manufacturer and verified by the RV dealer. If a new Zero Point is desired, follow the instructions in this section.

To set the Zero Point, first run a manual leveling sequence to get the coach to the desired level point. Then activate the Zero Point configuration mode. This mode is enabled by performing the following sequence:

1. Run a manual leveling sequence to set the trailer to the desired level point.
2. Activate the Zero Point configuration mode as follows:
 - A. Turn off touchpad.
 - B. Press FRONT button (Fig. 1G) 10 times.
 - C. Press REAR button (Fig. 1J) 10 times.

NOTE: An alarm will sound and the display will read ZERO POINT CALIBRATION; ENTER to set, Power to Exit (Fig. 6).

- D. Press ENTER (Fig. 1C) to set the Zero Point.
3. Screen will then display PLEASE WAIT.
4. An alarm will sound and the screen will display "Zero point set successfully" (Fig. 7).
5. The touchpad will then turn off.

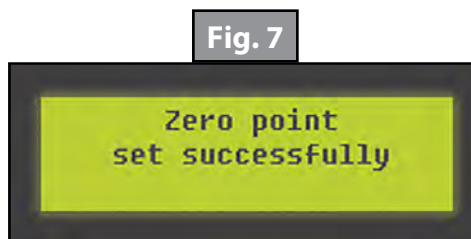
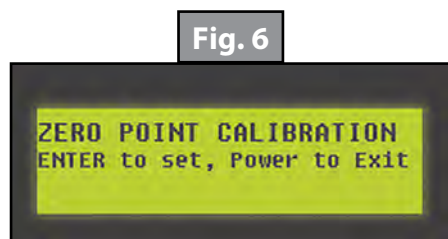

Maintenance

Fluid Recommendation

ATF with Dexron III® or Mercon 5® or a blend of both is recommended by Lippert.

Type "A" Automatic Transmission Fluid (ATF) is utilized and approved.

Hydraulic system operation in climates at or below 40 degrees F (4 degrees C) may result in the following:

- Slow operation during extension/retraction
- Incomplete retraction of jacks during Auto Retract procedure

NOTE: A visual inspection of the jacks in the retract position is recommended after completing Auto Retract.

For A List of Approved Fluid Specifications, Scan This QR Code
Or Go To: [TI-188 - Hydraulic Operation Fluid Recommendation](#).



Purging the Hydraulic System

⚠ WARNING

The coach should be supported at both front and rear axles with jack stands before working underneath. Failure to do so may result in death, serious personal injury or severe product or property damage.

NOTE: Make sure jacks are fully retracted prior to filling reservoir to prevent over-filling

1. Zip-tie any loose wiring or hydraulic lines.

NOTE: The basic purge procedure to bleed the Lippert Hydraulic Systems can be performed without the use of any tools. The hydraulic system will purge the air from the hydraulic lines and cylinders by simply running the pump.

NOTE: It is recommended to perform a minimum of three complete cycles (steps 2-7) to ensure both proper function and adequate fluid level of the system.

2. Start with all hydraulic components in the fully retracted position, meaning all jacks and slide-outs are brought back inside the coach as if the coach were ready for travel.
3. Find the hydraulic pump location and note the amount of fluid currently in the reservoir. The fluid level should be about 1/4" from the top of the reservoir and no more than 1/2" from the top.

NOTE: When checking the fluid level after ensuring all hydraulic components are retracted, note if there are any bubbles, froth or foam on top of the fluid. This is an indication that air has been pushed back to the reservoir when the hydraulic components were retracted in the last cycle. Wait 15-20 minutes for the foam to dissipate before beginning the purge process.

4. If there is no froth or foam in the reservoir and the fluid is not within 1/2" of the top, fill the reservoir to within the level described in step 3.
5. With the fluid level full and no foam in the reservoir, begin cycling the hydraulic system.
6. Extend jacks fully, taking the coach off the tires. If the coach has hydraulic slide-outs, extend all slide-outs. Once all jacks and slide-outs are extended, immediately retract all slide-outs and then jacks.
7. Check the reservoir foam. If foam is present, see NOTE following step 3 and then repeat steps 4-6. Repeat these steps until no foam is present in the reservoir. If no foam is present, the system is purged of air.

Preventative Maintenance

1. Check hydraulic fluid in reservoir every 12 months. If fluid is a clear, red color, do not change. If fluid is milky, pink and murky, and not clear red in color, drain reservoir and add new fluid. Hydraulic fluid in reservoir should be changed a minimum of every five years.

Wiring Diagram - Controller and Touchpad (Non-Water Resistant)

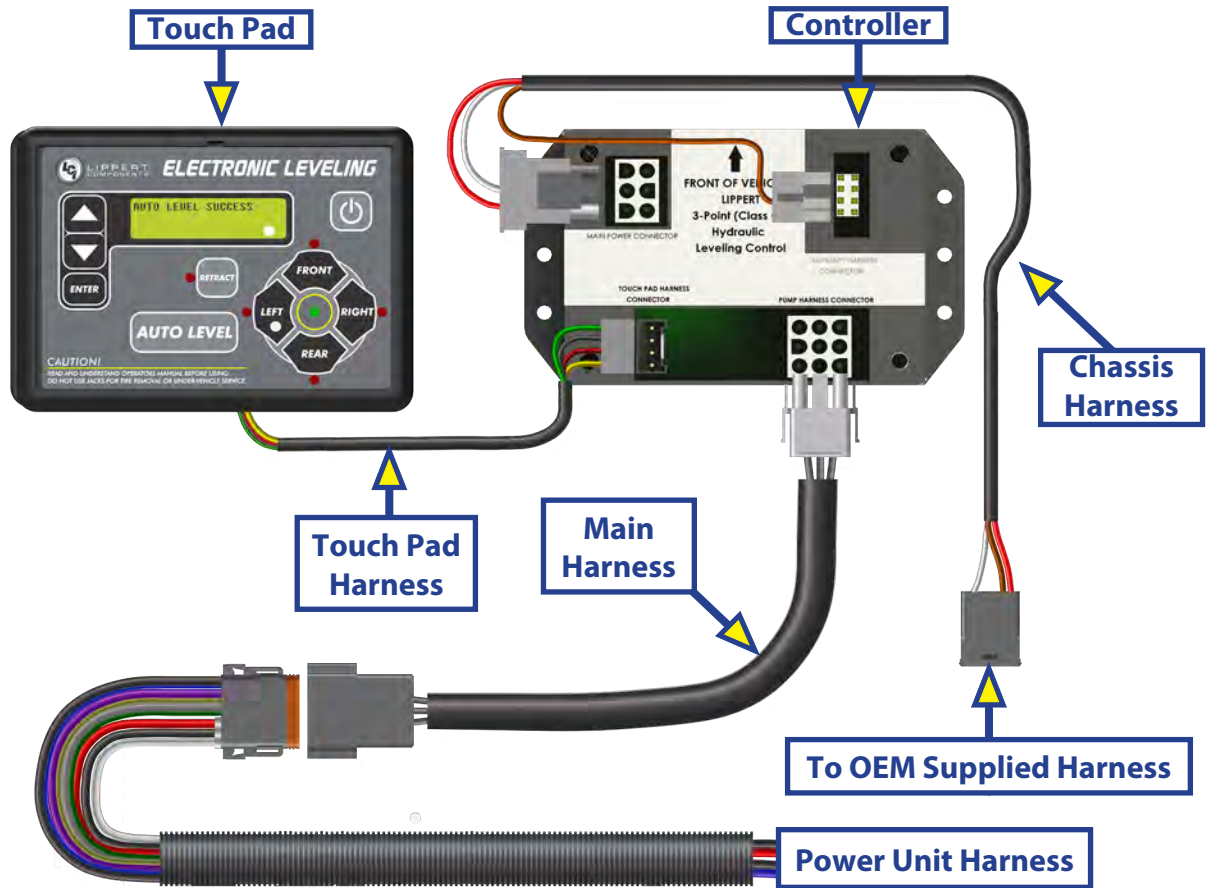

Wiring Diagram - Controller and Touchpad (Water Resistant)

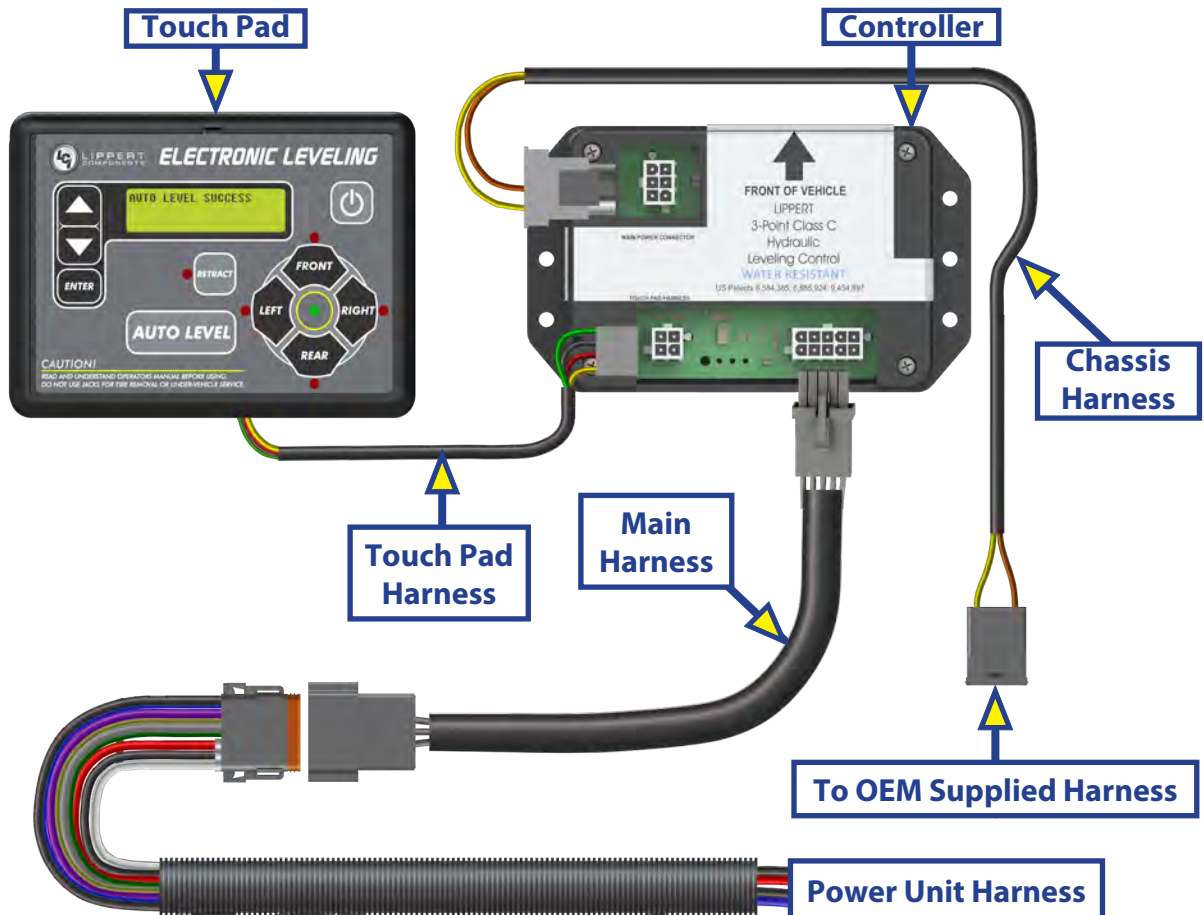

Hydraulic Plumbing Diagram (Aluminum Jacks)

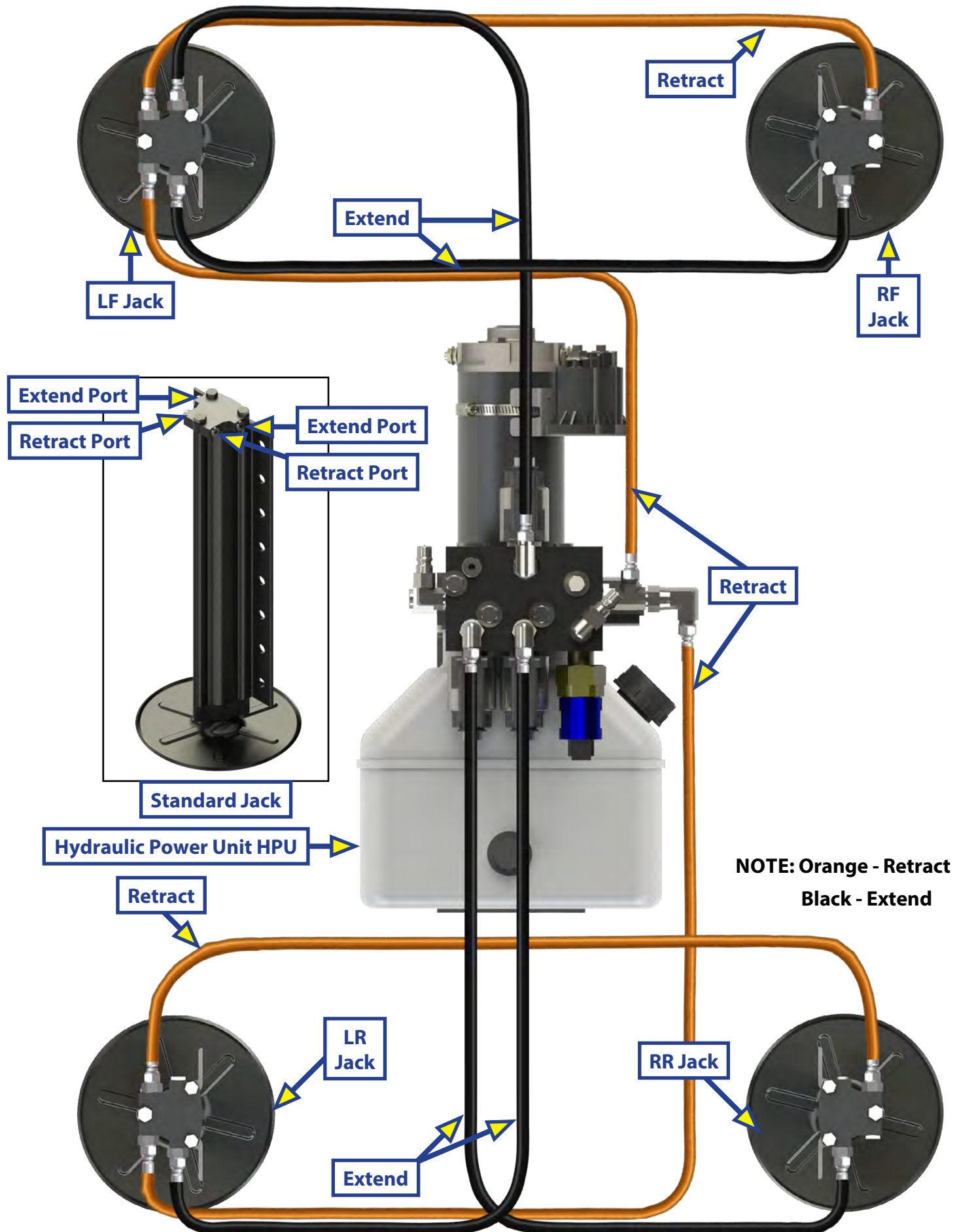

Hydraulic Plumbing Diagram (Steel Jacks)

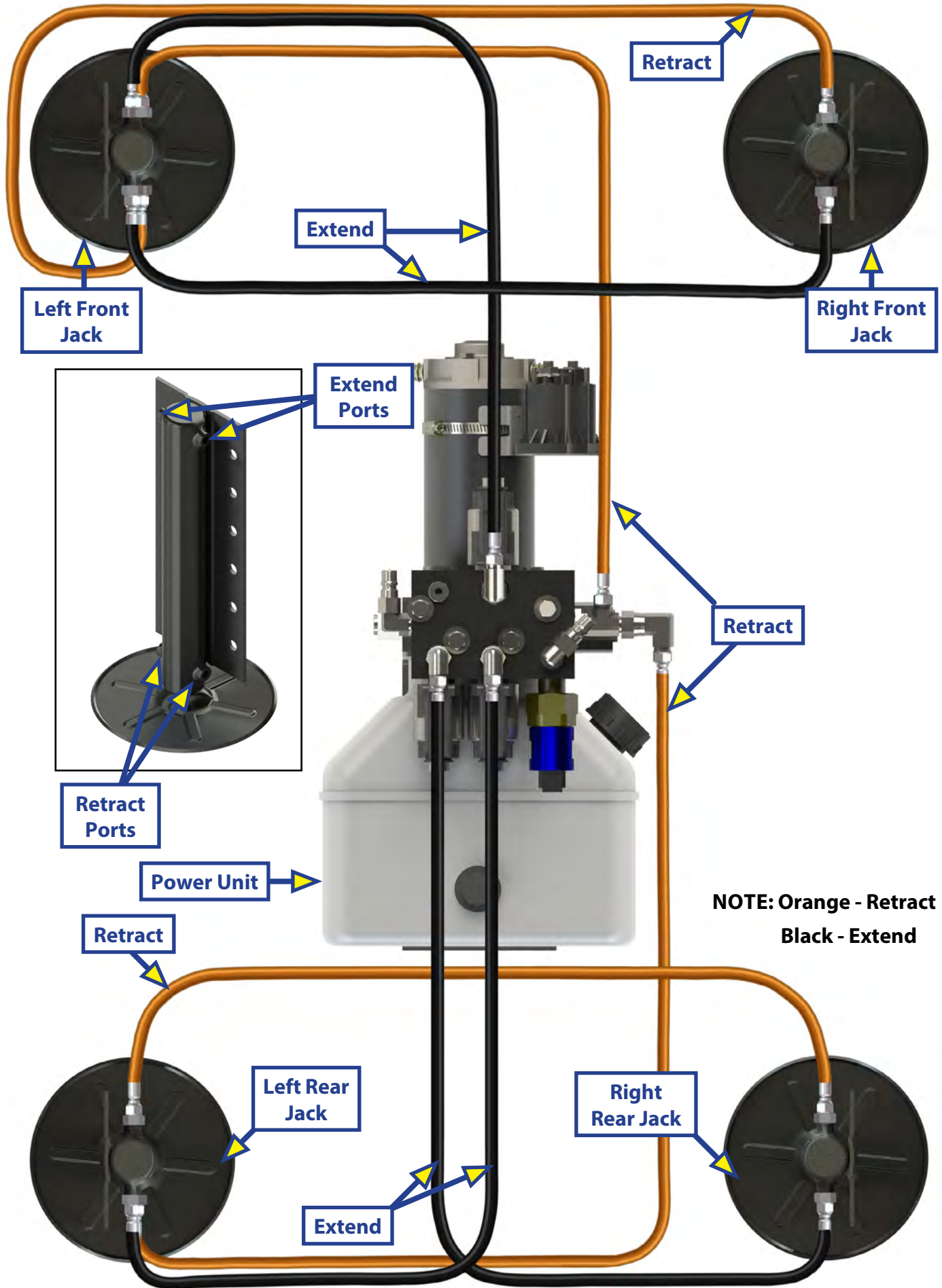



PATRIOT JACK SYSTEMS™
LEVELING
OWNER'S MANUAL



Scan for product support

TABLE OF CONTENTS

System Information	2
Component Description.....	2
Additional Information.....	3
Safety	3
Touchpad	5
Prior to Operation	5
Operation	6
Basic Jack Operation.....	6
Unhitching Instructions.....	6
Auto Level.....	6
Reconnecting to Tow Vehicle (Hitch Recognition).....	7
Pendant Switch.....	7
Troubleshooting	8
Error Codes.....	8
Manual Override.....	9
Zero Point Calibration.....	10
Maintenance	10
Hydraulic Fluid.....	10
Fluid Recommendation.....	11
Purging Procedure.....	11
Wiring Diagram - System	12
Plumbing Diagram - 6 Point Leveling	13

System Information

The Patriot Jack Systems Leveling includes six points of contact utilizing jacks and a multi-valve system. A 12V DC electric motor drives a hydraulic pump that moves fluid through a system of hoses, fittings and jacks to level and stabilize the trailer. Mechanical portions of the leveling system are replaceable. Contact Lippert to obtain replacement parts.

Component Description

1. Jacks
 - A. Aluminum leveling jacks, 8K capacity; landing gear, 14K capacity
 - B. Standard 9-inch diameter (63.5 square inch) footpads on a ball swivel for maximum surface contact on all surfaces
2. Motor/Pump Assembly
 - A. Motor, 12V DC
 - B. Hydraulic fluid reservoir, 1.75 gallon capacity
 - C. Solenoid
3. Control valve manifold
4. System Controls
 - A. Touchpad can be operated in manual mode or fully automatic mode
 - B. Pendant switch to independently operate landing gear
 - C. Sensors to detect when trailer is level
5. Fittings and Hoses
 - A. Fittings - High pressure O-Ring Face or JIC - Size 4
 - B. Hose - 1/4" I.D., 3000 psi - W.P. Rated

Additional Information

Additional information about this product can be obtained from lci1.com/support or by downloading the free LippertNOW app. The app is available on Apple App Store® for iPhone® and iPad® and also on Google Play™ for Android™ users.

Apple App Store®, iPhone®, and iPad® are registered trademarks of Apple Inc.
Google Play™ and Android™ are trademarks of Google Inc.

For additional support on this product go to: <https://support.lci1.com/patriot-jack-leveling-systems>.

NOTE: Images used in this document are for reference only when assembling, installing and/or operating this product. Actual appearance of provided and/or purchased parts and assemblies may differ.

Safety

Please read and study the manual before operating the leveling system. Adhere to all safety labels. This manual provides general instructions. Many variables can change the circumstances of the instructions, i.e., the degree of difficulty, operation and ability of the individual performing the instructions. This manual cannot begin to plot out instructions for every possibility, but provides the general instructions, as necessary, for effectively interfacing with the device, product or system. Failure to correctly follow the provided instructions may result in death, serious personal injury, severe product and/or property damage, including voiding of the Lippert limited warranty.

The use of the Lippert Patriot Jack Systems Leveling to support the trailer for any reason other than which it is intended is prohibited by the Lippert Limited Warranty. The system is designed as a leveling system only and should not be used for any reason to provide service under the trailer, e.g. changing tires or servicing the leveling system.

Lippert recommends that a trained professional be employed to change the tires on the trailer. Any attempts to change tires or perform other service while the trailer is supported by the leveling system could result in damage to the trailer and/or cause serious injury or death.

⚠ WARNING

The "WARNING" symbol above is a sign that a procedure has a safety risk involved and may cause death or serious personal injury, severe product and/or property damage if not performed safely and within the parameters set forth in this manual.

⚠ WARNING

Failure to follow instructions provided in this manual may result in death, serious personal injury and/or severe product and/or property damage, including voiding of the component warranty.

⚠ WARNING

The trailer **MUST** be supported per manufacturer's recommendations before working underneath. Failure to do so may result in death or serious personal injury, severe product and/or property damage, including voiding of the Lippert limited warranty.

⚠ CAUTION

The "CAUTION" symbol above is a sign that a procedure has a safety risk involved and may cause personal injury, product or property damage if not performed safely and within parameters set forth in this manual.

⚠ CAUTION

Always wear eye protection when performing service, maintenance or installation procedures. Other safety equipment to consider would be hearing protection, gloves and possibly a full face shield, depending on the nature of the task.

⚠ CAUTION

Moving parts can pinch, crush or cut. Keep clear and use caution.

Touchpad

Fig. 1

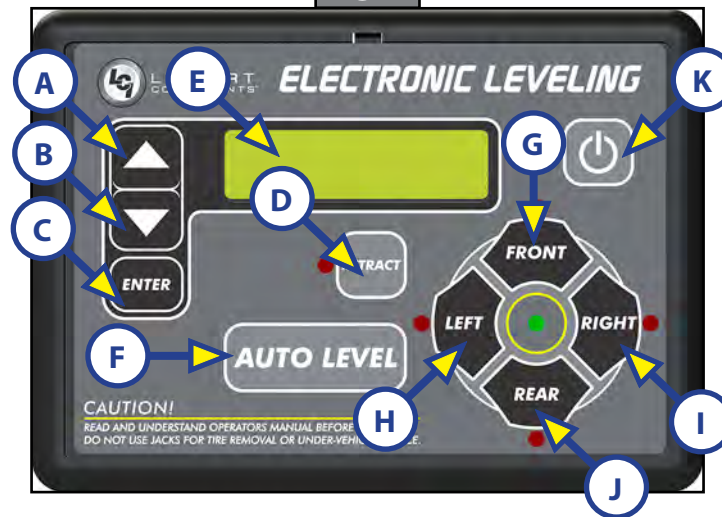

Callout	Description
A	Up Arrow - Scrolls up through the menu on LCD.
B	Down Arrow - Scrolls down through the menu on LCD.
C	ENTER - Activates modes and procedures indicated on LCD.
D	RETRACT - Places leveling system into retract mode.
E	LCD Display - Displays procedures and results.
F	AUTO LEVEL - Places leveling system into auto level mode.
G	FRONT Button - Activates both front jacks.
H	LEFT Button - Activates left leveling jack(s) in manual mode.
I	RIGHT Button - Activates right leveling jack(s) in manual mode.
J	REAR Button - Activates leveling jacks in manual mode.
K	Power Button - Turns leveling system on and off.

Prior to Operation

The leveling system shall only be operated under the following conditions:

1. The trailer is parked on a reasonably level surface.

CAUTION

Moving parts can pinch, crush or cut. Keep clear and use caution.

2. Make sure all people, pets and property are clear of the trailer while the leveling system is in operation.
3. Make sure the battery of the trailer is fully charged prior to attempting to operate the system. The automatic leveling system requires a minimum of 12V DC for operation.

Operation

Basic Jack Operation

1. Landing Gear
 - A. Landing gear can be operated any time the system is on, but not in AUTO MODE. Press the FRONT button (Fig. 1G), so that both the front jacks or landing gear can be extended.
 - B. If the touchpad is put in the RETRACT mode, indicated by the orange illuminated LED next to the RETRACT button (Fig. 1D), the landing gear can be retracted together by pressing the FRONT button.
 - C. The pendant switch can also be used to independently extend and retract the landing gear. See Pendant Switch section.
2. Leveling Jacks
 - A. The leveling jacks operate when AUTO mode is activated or the touchpad is in MANUAL mode. Once the system is in MANUAL mode, press the REAR button (Fig. 1H) to extend all leveling jacks at the same time.

NOTE: MANUAL and AUTO modes can be selected through the LCD menu by using the Up Arrow (UP) and Down Arrow (DOWN) buttons (Fig. 1A or Fig. 1B), then pressing ENTER to select the desired mode.

- B. Press the LEFT or RIGHT buttons (Fig. 1H or 1I) to operate leveling jacks on the left (roadside) or right (curbside) of the trailer.

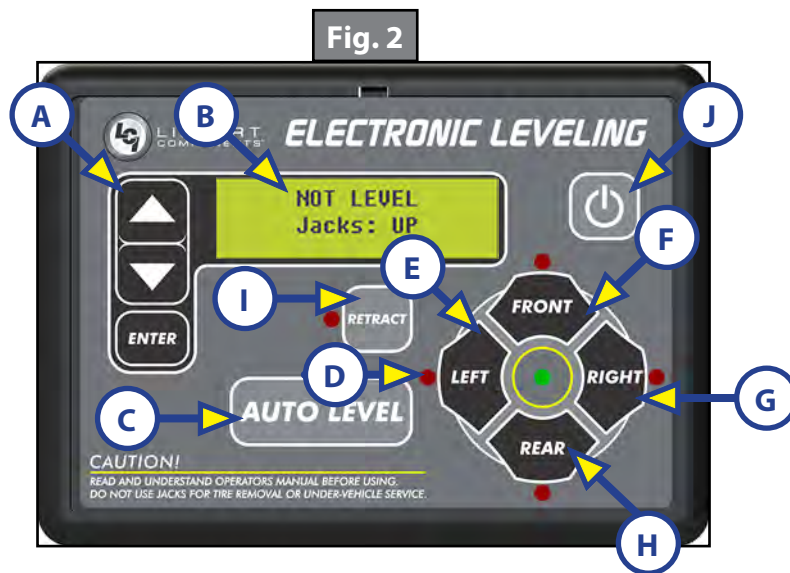

Unhitching Instructions

Prior to unhitching from tow vehicle, make sure trailer is parked on a level surface and the tires are chocked.

1. Press Power button (Fig. 2J) to turn system on. The LCD screen lights up.
2. The LCD will display NOT LEVEL Jacks: UP (Fig. 2B).

NOTE: Orange arrow lights (Fig. 2D) may come on indicating the current disposition of the trailer.

3. Disconnect any wires or chains that may be located between the tow vehicle and the trailer.
4. Press FRONT button (Fig. 2F) to extend landing gear to lift front of the trailer to take the weight of the trailer off the hitch.
5. Uncouple the connection on the tow vehicle.
6. Pull away the tow vehicle and park it at a safe distance.

Auto Level

1. After unhitching from tow vehicle, press AUTO LEVEL (Fig. 2C).

NOTE: Pressing any button during an automatic sequence will stop the sequence and a "Function Aborted" error code will occur. Press ENTER to clear the code and then continue the operation or start a new operation.

NOTE: For the hitch recognition feature to function, the auto-level sequence **MUST** be started with the front of the trailer above level.

2. Front landing gear will retract, lowering the front of the trailer below level, stopping, then lifting the front end to level the trailer front-to-back.
3. The left side leveling jacks extend and raise the roadside of the trailer.
4. The right side leveling jacks extend and raises the curbside of the trailer, beginning side-to-side leveling.
5. The front landing gear extend to complete the leveling cycle.
6. Additional left-to-right or front-to-back leveling may occur, if the controller deems necessary.

NOTE: If the auto-level sequence does not happen as stated above, check to ensure manual function works properly in all zones.

Reconnecting to Tow Vehicle (Hitch Recognition)

1. Turn on touchpad.
2. Press the LEFT and RIGHT buttons simultaneously (Fig. 2E and 2G).
3. The front of the trailer will raise to the height where the auto-level sequence was started.

NOTE: If the auto-level sequence was started with the front of the trailer in a below-level condition, the hitch recognition will not function and the LCD will display "Feature Disabled." For hitch recognition to function, the auto-level sequence must be started with the front of the trailer above level.

4. Connect tow vehicle and make sure trailer and hitch are connected and locked.
5. Connect any wires or chains that may be equipped between the tow vehicle and the trailer.
6. Press Up Arrow (Fig. 2G) until AUTO RETRACT appears in LCD screen.
7. Press ENTER.
8. System will immediately retract all jacks.

NOTE: A visual inspection of the jacks in the retract position is recommended after completing Auto Retract.

Pendant Switch

The front landing gear can be operated independently by utilizing the pendant switch installed on the front of the trailer. Before operating the landing gear, activate the pendant switch by turning it to the ON position (Fig. 3).

NOTE: The switch key should always be returned to the LOCK/OFF position after operating the landing gear and while towing the trailer.

1. Press the rocker switch to extend the landing gear (TRAILER UP) or retract the landing gear (TRAILER DOWN) (Fig. 3).
2. Release the switch when either the trailer is level or stabilized or the landing gear have been completely retracted.
3. Turn the key to the LOCK/OFF position.

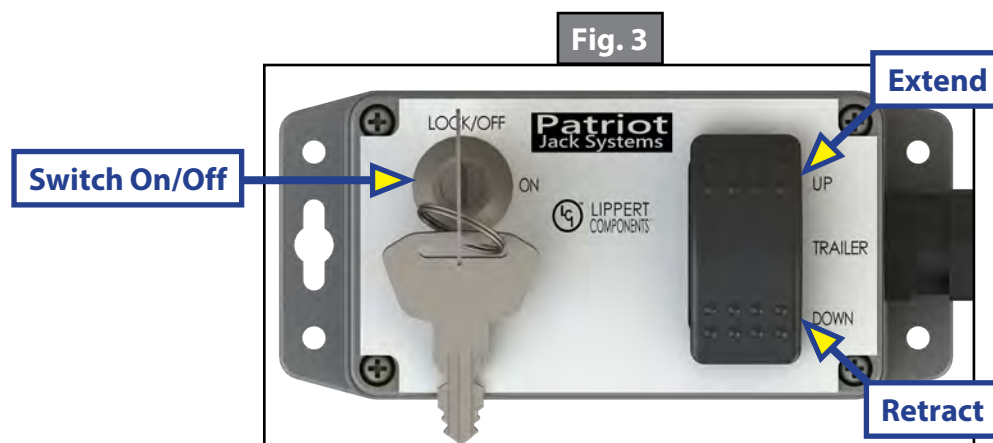

Troubleshooting

Error Codes



Make sure the trailer is supported at both front and rear with jack stands and in accordance with the manufacturer's recommendations to properly support the trailer before performing any service to trailer. Failure to do so may result in death, serious personal injury, severe product and/or property damage.

After working to resolve the issue that led to an error code, press ENTER on the touchpad. If the error is still present, the message will be displayed again. If resolved, the error message will clear.

Error Code Chart		
LCD Display	What Is Happening?	What Should Be Done?
Excess Angle	Controller not properly secured.	Check and secure controller placement.
	Excessive angle reached during auto operation.	Relocate the trailer.
Excessive Angle	Controller not properly secured.	Check and secure controller placement.
	Excessive angle reached during manual operation.	Stop manual operation and reset jacks to a more level state. The code will self clear; there is no need to hit ENTER. Relocate the trailer.
Feature Disabled	Front of trailer below level when starting auto level process but only when initiating Hitch Recognition feature.	Push the FRONT button to raise the trailer up to hitch height and connect to tow vehicle.
	Hitch recognition not set.	Set hitch angle.
	Zero Point not set.	Set Zero Point.
Low Voltage	Battery dropped below 9.5V.	Check wiring - repair or replace.
		Test battery voltage under load - charge or replace.
Out of Stroke	Jack has reached maximum stroke length and is unable to lift.	Check disposition of jacks or relocate the trailer.
External Sensor	Bad connection or wiring from the controller to the rear sensor.	Replace or repair connection to rear remote sensor.
Jack Time Out	The time limit is exceeded for the requested auto operation.	Check disposition of jacks.
Auto Level Fail	Unable to auto level due to uneven ground.	Check disposition of jacks and/or relocate the trailer.
	Unable to auto level due to Zero Point being set incorrectly.	Reset Zero Point.
Bad Calibration	Sensor calibration values are out of range.	Replace controller.
Internal Sensor	Internal sensor problem.	Replace controller.
Function Aborted	The user pressed a button on the touchpad during an automatic operation.	Restart automatic operation and then refrain from pressing any buttons on the touchpad.

Manual Override

Resources Required

- Cordless or electric drill or screw gun
- $\frac{1}{4}$ " hex bit
- $\frac{5}{32}$ " hex wrench

The leveling system can be manually operated with an electric drill. In the event of electrical or system failure, this manual override method of extending and retracting the jacks can be used.

NOTE: Unhook the hydraulic power unit motor from the main power source (battery) prior to attempting the manual override procedure.

1. Locate the valves that are paired with the landing gear and roadside and curbside leveling jacks to be manually overridden (Fig. 4). Also see Wiring and Plumbing diagrams.
2. Using a $\frac{5}{32}$ " hex wrench, open the three valves by turning the manual override set screw clockwise (Figs. 4 and 5).
3. Remove protective label (Fig. 6) from power unit motor to reveal the manual override coupler.
4. Using an electric drill with a $\frac{1}{4}$ " hex bit, insert the hex bit into the manual override coupler (Fig. 7) to manually operate the system.
 - A. Run the drill forward (clockwise) to retract the landing gear and/or leveling jacks.
 - B. Run the drill in reverse (counterclockwise) to extend the landing gear and/or leveling jacks.
5. After extending or retracting the landing gear and leveling jacks, make sure to turn the manual override set screw on each valve back to the counterclockwise position using the hex wrench (Fig. 8).

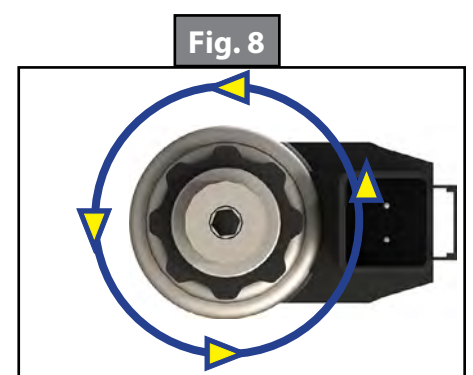
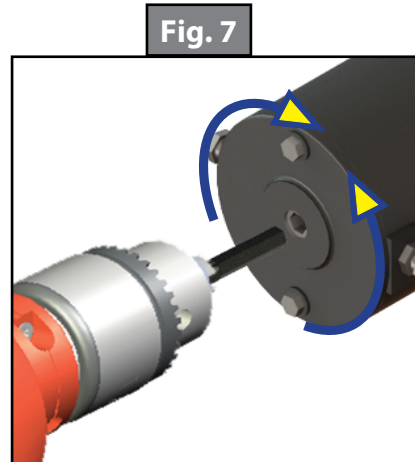
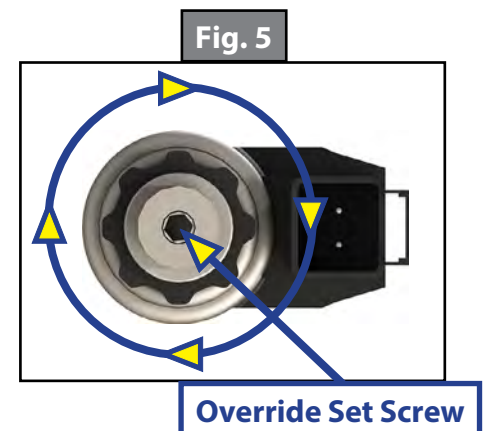
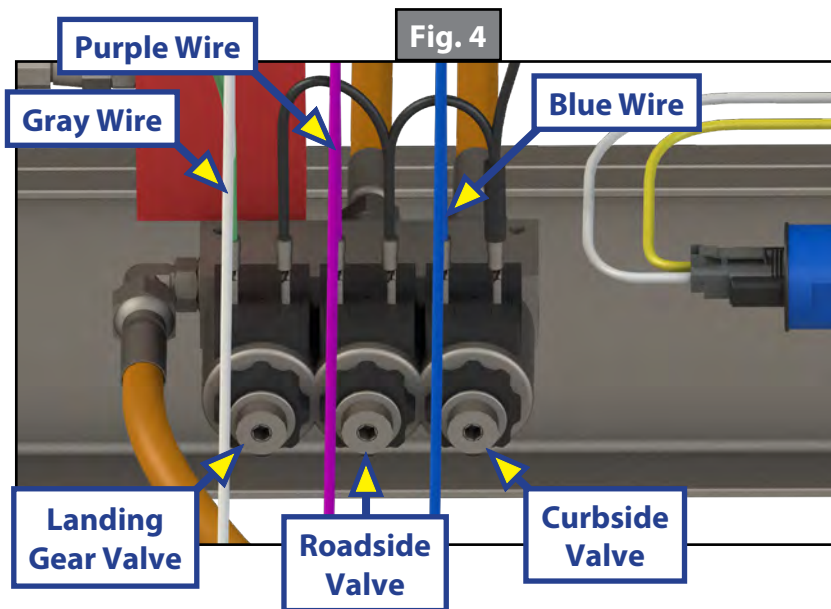

Zero Point Calibration

Zero Point Calibration is the point the leveling system will return to when an auto-leveling cycle is initiated. The Zero Point Calibration was set by the RV manufacturer and verified by the RV dealer before auto-leveling features were available. To set a new Zero Point, do as follows:

1. Run a manual leveling sequence to set the trailer to the desired level point.
2. Activate the Zero Point configuration mode as follows:
 - A. Turn off touchpad.
 - B. Press FRONT button (Fig. 1G) 10 times.
 - C. Press REAR button (Fig. 1J) 10 times.

NOTE: An alarm will sound and the display will read ZERO POINT CALIBRATION; ENTER to set, Power to Exit (Fig. 9).

- D. Press ENTER (Fig. 1C) to set the Zero Point.
3. Screen will then display PLEASE WAIT.
 4. An alarm will sound and the screen will display "Zero point set successfully" (Fig. 10).
 5. The touchpad will then turn off.

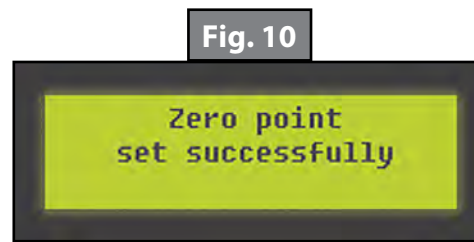
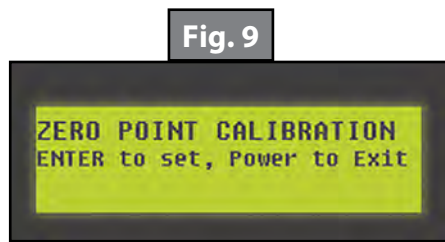

Maintenance

1. Remove dirt and road debris from leveling jacks and landing gear and stabilizer struts (if equipped) as needed.
2. If jacks are down for extended periods, it is recommended to spray exposed jack tubes with a spray lubricant every three months for protection. If the trailer is located in a salty air environment, it is recommended to spray the jack tubes every four to six weeks.
3. Inspect and clean all of the power and electrical connections prior to the first use of the trailer at the start of the traveling season and prior to storing the trailer. If corrosion is evident, clean all corrosion with a wire brush, then apply dielectric grease to the connections.
4. Make sure to turn the manual override set screw on the valve back to the counterclockwise position after extending or retracting the landing gear or leveling jacks.

Hydraulic Fluid

1. Each month, check that the fluid level is within $\frac{1}{4}$ " of the reservoir fill spout lip while leveling jacks and slide-outs are fully retracted.

NOTE: Always fill the reservoir with the leveling jacks and slide-outs fully retracted. Filling the reservoir when leveling jacks and slide-outs are extended will cause the reservoir to overflow into its compartment when the leveling jacks and slide-outs are retracted.

2. Check the color of the hydraulic fluid in the reservoir every 12 months. If fluid is a clear, red color, do not change. If fluid is milky, pink and murky and not clear red in color, drain reservoir and add new fluid. Hydraulic fluid in reservoir should be changed a minimum of every five years.

Fluid Recommendation

ATF with Dexron III® or Mercon 5® or a blend of both is recommended by Lippert.

Type "A" Automatic Transmission Fluid (ATF) is utilized and approved.

Hydraulic system operation in climates at or below 40 degrees F (4 degrees C) may result in the following:

- Slow operation during extension/retraction
- Incomplete retraction of jacks during Auto Retract procedure

NOTE: A visual inspection of the jacks in the retract position is recommended after completing Auto Retract.

For a list of approved fluid specifications, scan this QR Code or go to: [TI-188 - Hydraulic Operation Fluid Recommendation](#).



Purging Procedure

⚠ WARNING

Do not attempt to purge this system without the front end of the trailer safely supported. Purging the system without properly supporting the trailer could result in death or serious injury.

⚠ CAUTION

Use appropriate personal protective equipment (PPE) for the procedure being performed.

Refer to [TI-118](#), Basic Purge Procedure for Hydraulic Pumps To obtain this Technical Information sheet online, go to <https://support.lci1.com/towable-br-level-up-support-towable-level-up-br-touch-pad>. Then click on the Technical Information Sheets tab. Look for *TI-118: Basic Purge Procedure for Hydraulic Pumps* within the listing.

1. Purging of the hydraulic system should be performed with the trailer coupled to the tow vehicle, a kingpin stand under the pin box or jack stands under the front portion of the frame.
2. Start with all hydraulic components in the fully retracted position, meaning all jacks, landing gear, stabilizers and slide-outs brought back inside the trailer as if it were ready to travel.
3. Find the hydraulic pump location and note the amount of fluid currently in the reservoir. The fluid level should be about $\frac{1}{4}$ " from the top of the reservoir and no more than $\frac{1}{2}$ " from the top.

NOTE: When checking the fluid level after ensuring all hydraulic components are retracted, note if there are any bubbles, froth or foam on top of the fluid. This is an indication that air has been pushed back to the reservoir when the hydraulic components were retracted in the last cycle. Wait 15-20 minutes for the foam to dissipate before beginning the purge process.

4. If there is no froth or foam in the reservoir and the fluid is not within $\frac{1}{2}$ " of the top, fill the reservoir to within the level described in step 3.
5. With the fluid level full and no foam in the reservoir, begin cycling the hydraulic system:
 - A. Extend hydraulic landing gear until footpads contact the ground.
 - B. Extend hydraulic leveling jacks to touch the ground.
 - C. Extend any slide-outs, if applicable.
 - D. Retract any slide-outs, if applicable.
 - E. Retract hydraulic leveling jacks.
 - F. Retract hydraulic landing gear.
6. Check the reservoir for foam. If foam is present, see **NOTE** above and repeat steps 4 and 5.
7. Repeat these steps until no foam is present in the reservoir. If no foam is present, the system is purged of air.

Wiring Diagram - System

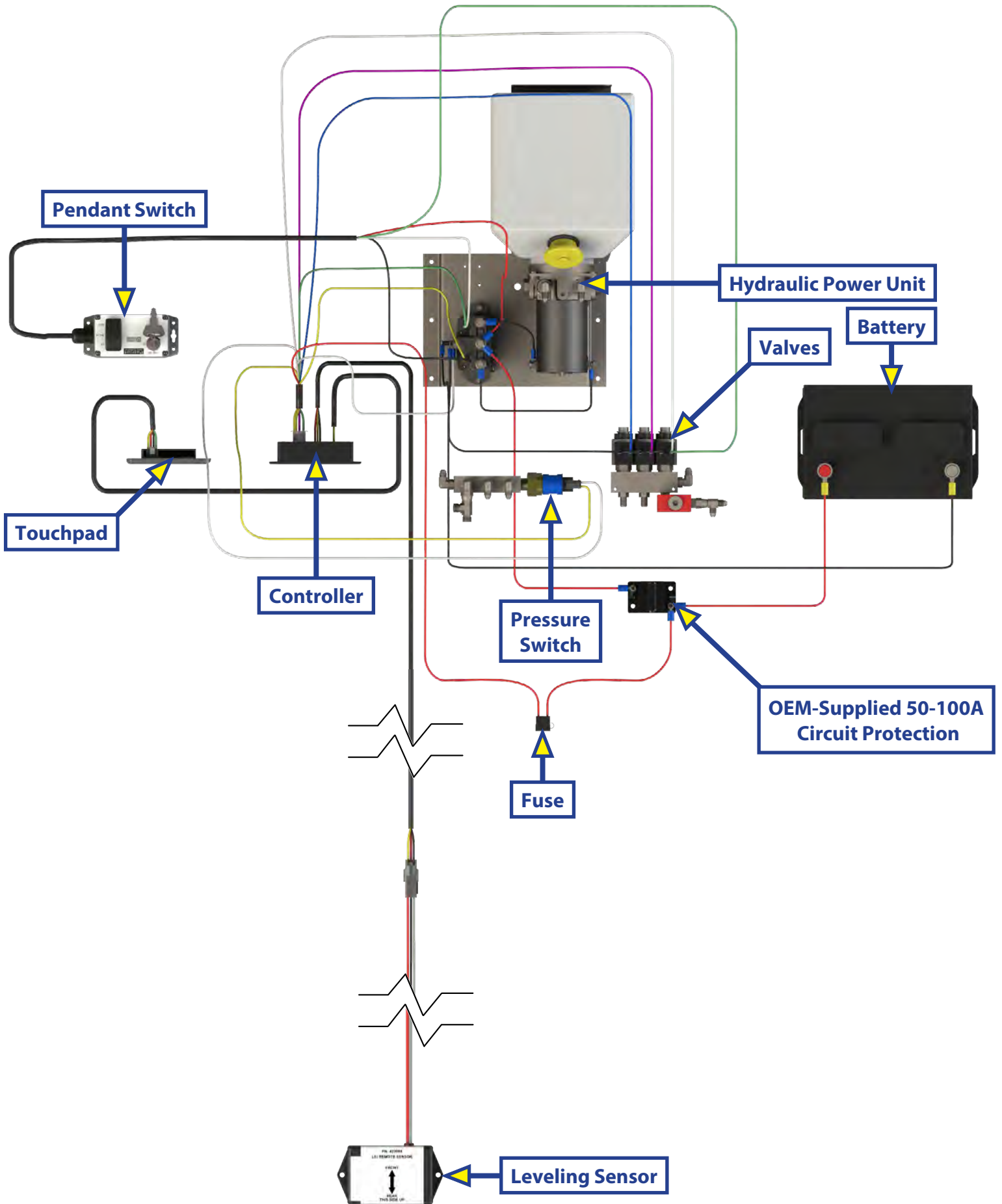

Plumbing Diagram - 6 Point Leveling

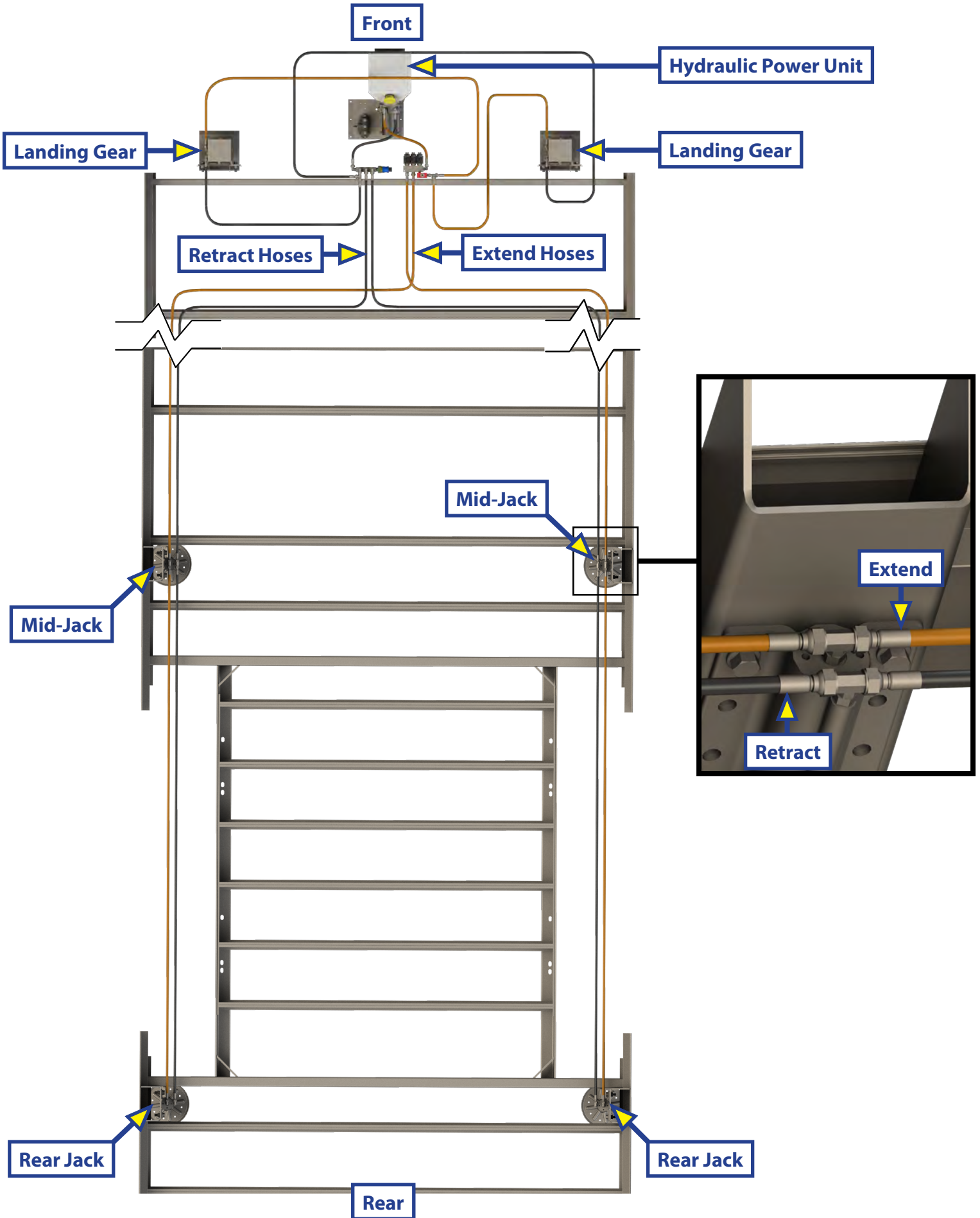



HYDRAULIC LEVELING
(4POINT/4 VALVE SPRINTER)
OWNER'S MANUAL



Scan for product support

TABLE OF CONTENTS

Introduction	2
Safety	3
System Features	4
Fluid Recommendation	4
Component Description	4
Power Unit Components	5
Prior to Operation	6
Operation	6
Selecting a Site	6
Touchpad Operation	7
Automatic Leveling Procedure	8
Manual Leveling Procedures	8
Jack Retract Procedures	9
Troubleshooting	9
Automatic Safety Shutoff	9
Drive Away Protection System	10
Error Mode	10
Level Zero Point Calibration	10
Manual Override - Jacks	11
Manual Override - Power System	11
"Jacks Down" Alarm	12
User Alarm Mode	12
Low Voltage Signal	12
Preventative Maintenance Procedures	13
Latched Out Warning	13
Troubleshooting Chart	14
Plumbing Diagram	15
Wiring Diagrams	16
Notes	17

Introduction

The four-point four-valve hydraulic leveling system is a hydraulic system which includes four points of contact utilizing aluminum jacks and a four-valve manifold system. A 12V DC electric motor drives a hydraulic pump that moves fluid through a system of hoses, fittings and jacks, to level and stabilize the coach. Mechanical portions of the hydraulic leveling system are replaceable. Contact Lippert to obtain replacement parts.

Additional information about this product can be obtained from lci1.com/support or by downloading the free myLCI app. The myLCI app is available for free on Apple App Store® for iPhone® and iPad® and also on Google Play™ for Android™ users.

App Store® and iPad® are registered trademarks of Apple Inc.
Google Play™ and Android™ are trademarks of Google Inc.

For additional product support go to: [Hydraulic Leveling \(4 Point / 4 Valve Sprinter\) | Lippert Customer Care Center](#)

NOTE: Images used in this document are for reference only when assembling, installing and/or operating this product. Actual appearance of provided and/or purchased parts and assemblies may differ.

Safety

Read and understand all instructions before installing or operating this product. Adhere to all safety labels.

This manual provides general instructions. Many variables can change the circumstances of the instructions, i.e., the degree of difficulty, operation and ability of the individual performing the instructions.

This manual cannot begin to plot out instructions for every possibility, but provides the general instructions, as necessary, for effectively interfacing with the device, product or system. Failure to correctly follow the provided instructions may result in death, serious personal injury, severe product and/or property damage, including voiding of the Lippert limited warranty.

WARNING

The "WARNING" symbol above is a sign that a procedure has a safety risk involved and may cause death or serious personal injury if not performed safely and within the parameters set forth in this manual.

WARNING

Failure to follow instructions provided in this manual may result in death, serious personal injury and/or severe product and property damage, including voiding of the component warranty.

WARNING

Lifting all wheels off the ground may result in serious personal injury or death.

WARNING

Your coach should be supported at both front and rear axles with jack stands before working underneath. Failure to do so may result in personal injury or death.

CAUTION

The "CAUTION" symbol above is a sign that a safety risk is involved and may cause personal injury and/or product or property damage if not safely adhered to and within the parameters set forth in this manual.

CAUTION

Always wear eye protection when performing service, maintenance or installation procedures. Other safety equipment to consider would be hearing protection, gloves and possibly a full face shield, depending on the nature of the task.

System Features

- Automatic extension of jacks from full retract position (with automatic ground detection).
- Automatic leveling of jacks.
- Manual leveling of jacks
- Automatic retraction of jacks (with automatic full retract detection).
- Emergency retract/User alarm mode (jacks not retracted and park brake disengaged).
- Automatic jack error detection and error mode.
- Configurations mode for Leveling Zero Point.
- Remote operation.

Fluid Recommendation

The Lippert Electronic Leveling System is pre-filled, primed and ready to operate direct from the manufacturer. Type "A" Automatic Transmission Fluid (ATF) is utilized and will work. ATF with Dexron III® or Mercon 5® or a blend of both is recommended by Lippert.

In colder temperatures (less than 10° F) the jacks may extend and retract slowly due to the fluid's molecular nature. For cold weather operation, fluid specially formulated for low temperatures may be desirable. For a list of approved fluid specifications, see [TI-188](#).

Component Description

The Lippert Electronic Leveling System consists of the following major components:

- Lippert jacks are rated at a lifting capacity appropriate for your coach. Each jack has a 9" diameter (63.5 Square inch) shoe on a ball swivel for maximum surface contact on all surfaces. (12" Dia. - 113 Sq. In. shoe also available).
- Each jack is powered from a central 12V DC (Fig.1) motor/pump assembly, which also includes the hydraulic oil reservoir tank, control valve manifold, and solenoid valves.
- The Lippert Electronic Leveling System is controlled electronically from the driver's seat of the coach. The touchpad is mounted in the dash. The system can be operated in a manual mode or a fully automatic mode.

Fig. 1

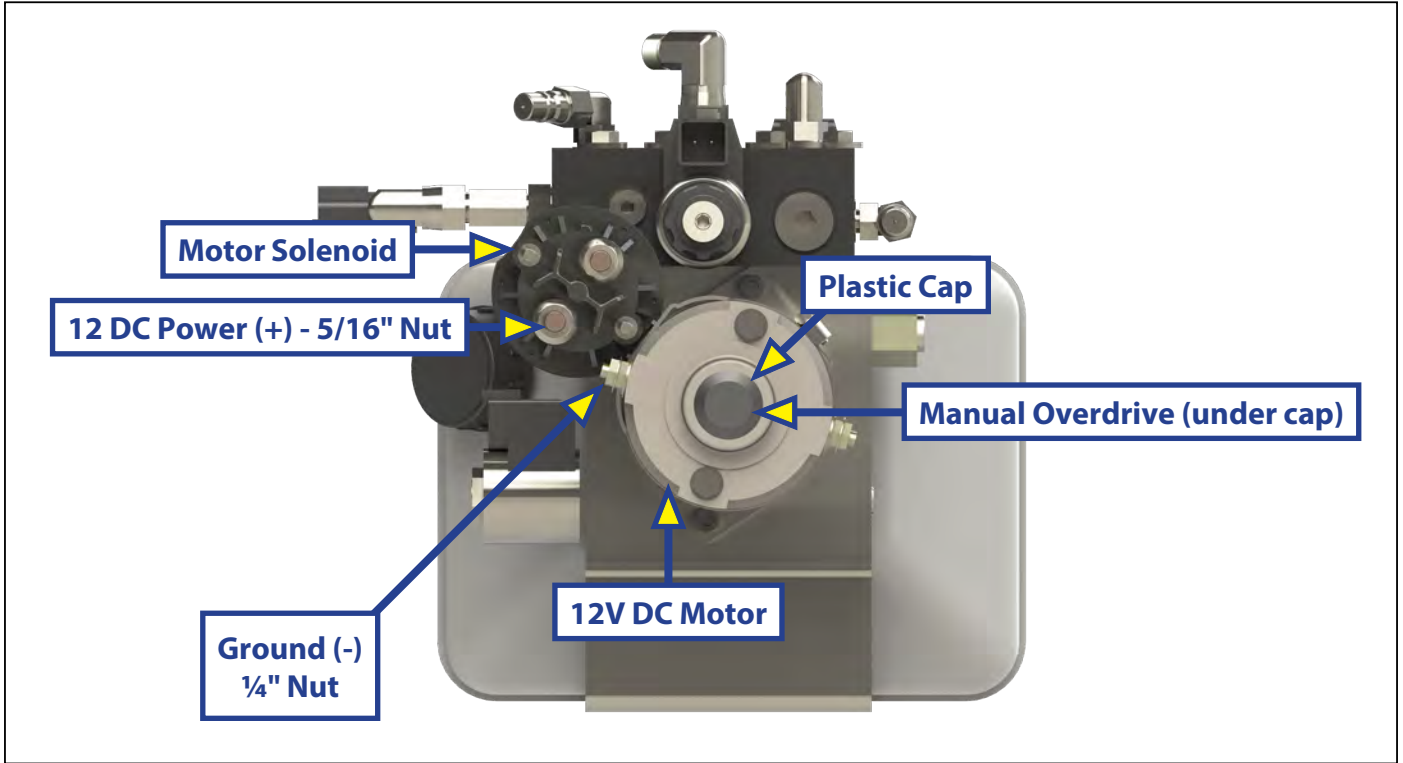

Leveling Only

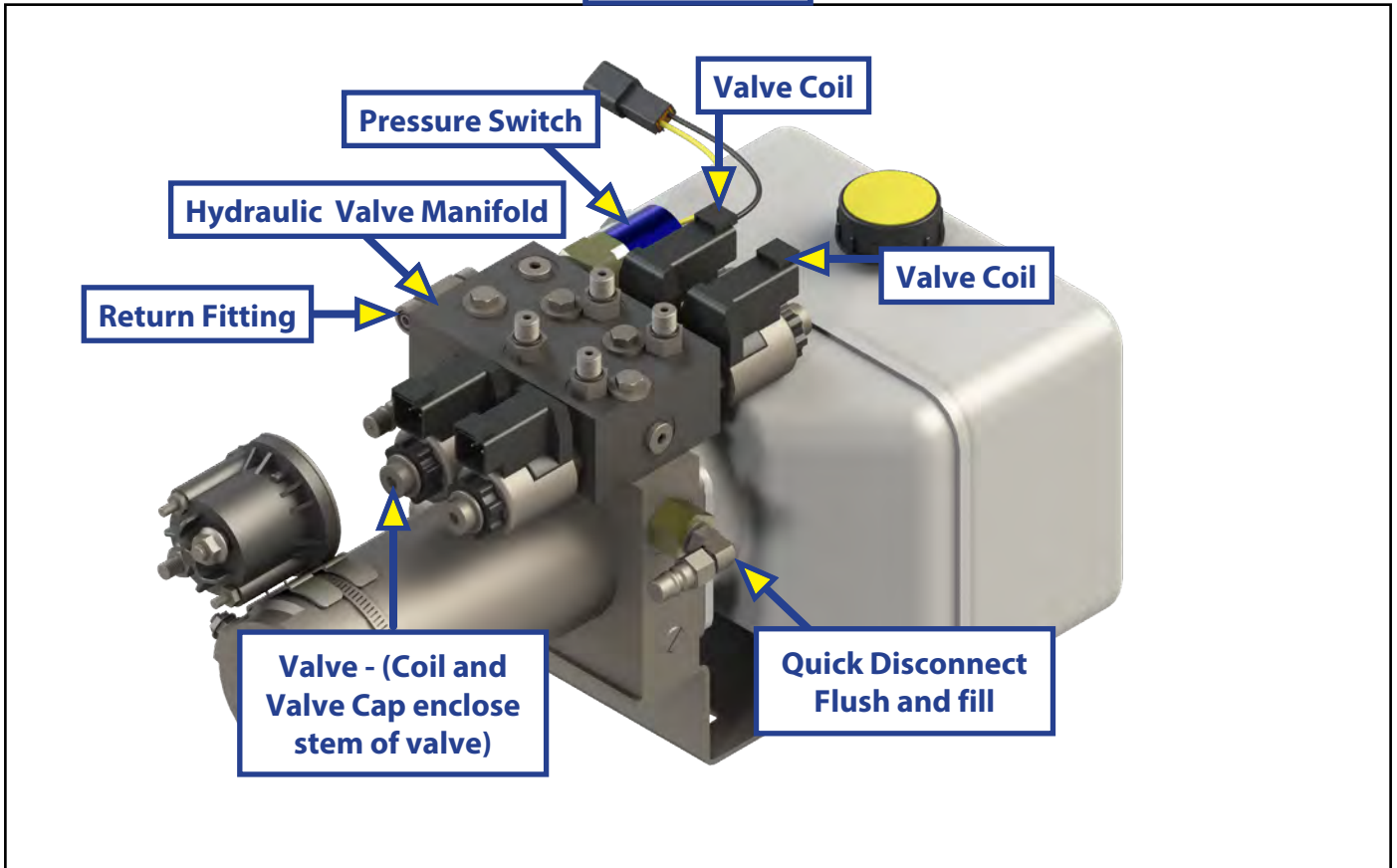

Prior to Operation

The leveling system shall only be operated under the following conditions:

1. The coach is parked on a reasonably level surface, engine running.
2. The coach "parking brake" is engaged.
3. All jack landing locations are cleared of debris and obstructions.
4. The coach transmission should be in the park position.
5. Locations should also be free of depressions.

NOTE: When parking the coach on extremely soft surfaces, utilize load distribution pads under each jack.

6. People and pets should be clear of coach while operating leveling system.
7. Be sure to keep hands and other body parts clear of fluid leaks. Oil leaks in the Lippert Leveling System may be under high pressure and can cause serious skin penetrating injuries.
8. Never lift the coach completely off the ground. Lifting the coach so the wheels are not touching ground will create an unstable and unsafe condition.

Operation

Selecting a Site

When the coach is parked on an excessive slope, the leveling requirements may exceed the jack lift stroke capability. If the coach is parked on an excessive slope, the coach should be moved to a more level surface before the leveling system is deployed.

- Make sure jacks are retracted before attempting to auto level. (The System will perform full retract automatically if jacks are not down on the request of an auto cycle).
- System will refuse any operation when a low voltage condition is present.
- System will automatically alarm and retract if park brake is disengaged and jacks are not retracted with any change in sensor readings.

When in alarm mode, the only available feature is to retract all jacks.

- The LEDs blink differently when in special controller modes (error, alarm and configuration). Learning how to recognize these modes is important.
- Excess slope LED blinks whenever the Y axis (vehicle length) is over 5 degrees from programmed level point.

Fig. 2

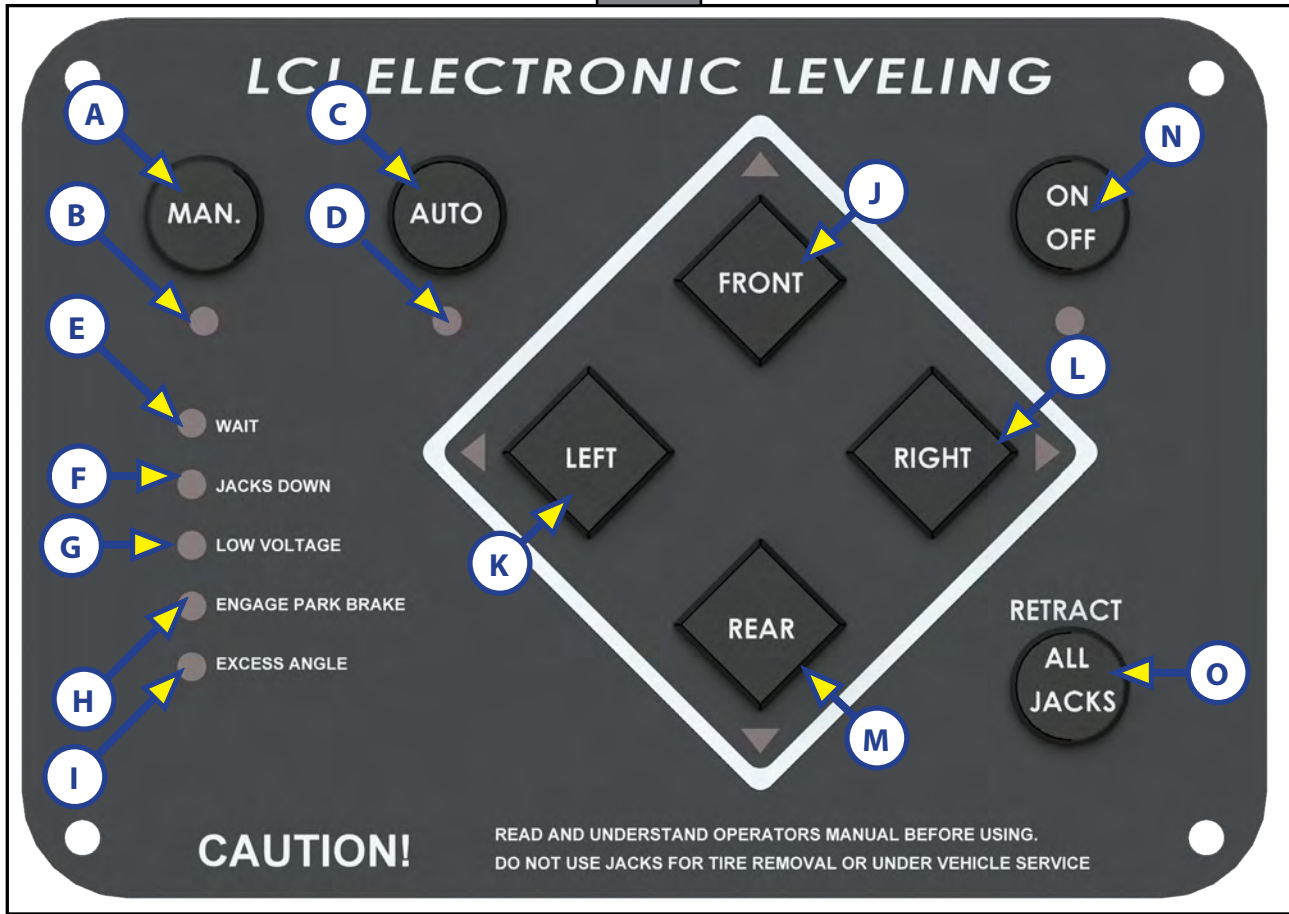

Callout	Description
A	Manual Operation - Places touchpad in manual operation mode.
B	Manual Operation LED - Indicates touchpad in manual operation mode.
C	Automatic Operation - Places touchpad in automatic operation mode.
D	Automatic Operation LED - Indicates touchpad in automatic operation mode.
E	Wait LED - Indicates to the operator to pause operation until the LED turns off.
F	Jacks Down LED - Indicates jacks are not fully retracted.
G	Low Voltage LED - Indicates voltage has dropped below safe operable level. Solid LED indicates voltage is too low to operate system.
H	Engage Park Brake LED - Flashes when park brake is disengaged; off when park brake has been engaged.
I	Excess Angle LED - Coach may not be able to level in current location and must be moved to a more level location.
J	Front Button - Controls operation of both front jacks.
K	Left Button - Controls operation of both left jacks.
L	Right Button - Controls operation of both right jacks.
M	Rear Button - Controls operation of both rear jacks.
N	Power Button - Turns system on and off.
O	Retract All Jacks - Retracts all jacks automatically.

Automatic Leveling Procedure

Refer to (Fig. 2) for questions regarding location and functions of the Lippert Electronic Leveling System. Coach must be running and parking brake must be engaged for LCI Electronic Leveling System to operate.

1. Push ON/OFF (Fig. 2N) button on touchpad. The system is now operational and the electronic level lights will become active.
2. Check to see that the touchpad ENGAGE PARK BRAKE (Fig. 2H) light is not flashing.
3. Push the AUTO (Fig. 2C) button to begin the automatic leveling cycle.

NOTE: After starting the automatic leveling cycle it is very important that you do not move around in the coach until the coach is level. This could have an affect on the performance of the leveling system.

4. If further adjustments are necessary, refer to the Manual Leveling Procedures section.
5. Push power button to turn off the system.
6. Visually inspect all jacks to ensure all shoes are touching ground. Should one of the rear jack shoes not be touching the ground. Push the corresponding LEFT (Fig. 2K) or RIGHT (Fig. 2L) buttons to lower the corresponding jack to the ground.

Manual Leveling Procedures

When leveling your coach, the coach should be leveled from front to rear first. When the coach is level from front to rear, then level the coach from left to right. Coach must be running for LCI Electronic Leveling System to operate.

1. Push ON/OFF (Fig. 2N) button on touchpad. The system is now operational, ON/OFF light will be lit.
2. Push and hold MAN (Fig. 2A) button for 5 seconds.
3. Push FRONT (Fig. 2J) button until jacks contact the ground and lift the front of the coach 1-2 inches.
4. Push REAR (Fig. 2M) button until jacks contact the ground and lift rear of coach.
5. Press FRONT (Fig. 2J) or REAR (Fig. 2M) button; if light is on at the FRONT button press the FRONT (Fig. 2J) button; if the light is on at REAR button press the REAR (Fig. 2M) button. Continue to hold until the light goes out.
6. Push LEFT (Fig. 2K) or RIGHT (Fig. 2L) button: If light is on at RIGHT button, push RIGHT button; if the light is on at LEFT button push LEFT button. Continue to hold until the light goes out.
7. The right and left jacks are used to level the coach side to side. Pushing the LEFT button on the touchpad will extend both left jacks. Pushing the RIGHT button on the touchpad will extend both right jacks. Jacks always work in pairs, both front jacks; both right side jacks, etc.
8. Repeat steps 2 through 6 if needed.
9. Turn power off to leveling system by pushing ON/OFF (Fig. 2N) button.
10. Visually inspect all jacks to ensure all shoes are touching ground. Should one of the rear jack shoes not be touching the ground, press the corresponding LEFT (Fig. 2K) or RIGHT (Fig. 2L) rear jack buttons to lower the corresponding jack to the ground.

⚠ WARNING

Lifting all wheels off the ground may result in serious personal injury or death.

Fig. 3

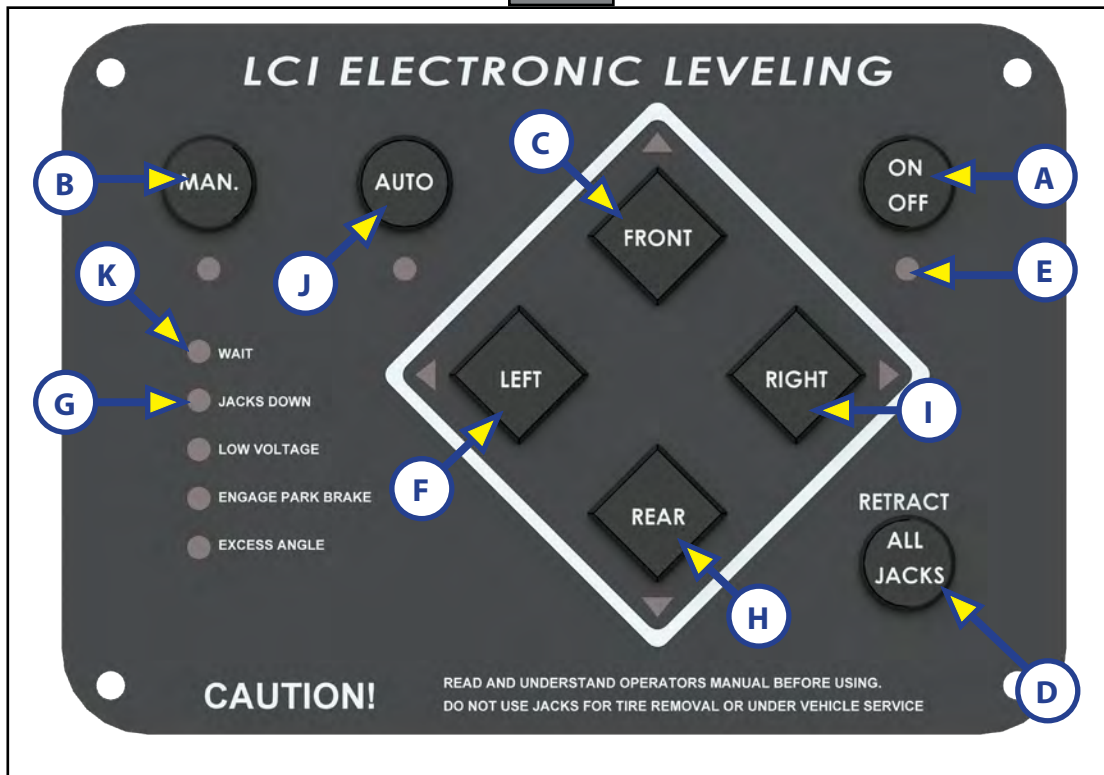

Jack Retract Procedures

1. Energize the system by pushing ON/OFF (Fig. 3A) button on touchpad. The ON/OFF light (Fig. 3E) will be lit.
2. Push the RETRACT ALL JACKS (Fig. 3D) button. All the jacks will start to retract and return to the full retract position. When jacks return to full retract position the JACKS DOWN (Fig. 3G) light will go out.
If you wish to stop the jacks from retracting, turn the system off and back on again by pushing the ON/OFF button twice. You can then re-level the coach by following steps 1-6 again.
3. When the JACKS DOWN (Fig. 3G) light goes out, push the ON/OFF (Fig. 3A) button on the touchpad to de-energize the system. After a brief visual inspection around the coach to verify the jacks are fully retracted, you may proceed to travel.

When in the MANUAL mode, if the RETRACT button is pushed the jacks will only retract as long as the RETRACT button is depressed. In AUTOMATIC mode, the RETRACT button need only be pressed once and released for the jacks to fully retract.

Troubleshooting

Automatic Safety Shutoff

If the touchpad is left on and inactive for four minutes it will shut off automatically. To reset the system the coach ignition must be turned off, then back on and the ON/OFF button must again be pushed.

Drive Away Protection System

If the ignition is in the "RUN" position, jacks are down, and the operator releases the parking brake, all indicator lights will flash and the alarm beeper will activate. The system will then automatically retract the jacks until the jacks are fully retracted or the operator resets the parking brake. The power unit will also operate to keep the jacks retracted in the event the leveling system loses pressure as the coach is being driven.

Error Mode

If any problem is detected with the jacks, the system will enter Error Mode. Error mode may be recognized by the blinking of Left, Center LCI and Right LEDs. The following errors are detected by this system:

- Jack over current/short circuit.
- Jack under current/ open circuit.
- Jack extending too long (ground not detected after 2 minutes).
- Jack retracting too long (fully retracted not detected after 2 minutes).
- Out of stroke detection during auto cycle (if enabled).

The user must respond by pressing On/Off switch, which resets operation. All normal features are disabled in Error Mode. If panel loses communication with the controller for more than 5 seconds, the panel will blink the Jacks Down, Park Brake and ON/OFF (if included) LEDs.

Level Zero Point Calibration

The Zero Point is the programmed point that the coach will return to each time the Auto Level feature is used. The Zero Point must be programmed prior to using the Auto Level feature to ensure the proper operation of the system. To set the zero point, the control module must be fully secured in the production intent location. Activate the Level Zero point configuration mode by following the steps below:

1. Turn system on by pressing the "ON/OFF" (Fig. 3A). The "ON/OFF" indicator light (Fig. 3E) will illuminate.
2. Press the "MAN" (Fig. 3B) and hold for 2-3 seconds. The indicator light below the "MAN" button will then illuminate. This will put the system into "MANUAL" mode.
3. Level the coach in "MANUAL" mode by using a carpenter's level on the floor. Level front to rear and then left to right.
 - A. Push the "FRONT" (Fig. 3C) button until both front jacks contact the ground and lift the front of the coach 1-2 inches.
 - B. Push "REAR" (Fig. 3H) button until both rear jacks contact the ground and lift rear of coach. Keep button depressed until the carpenter's level bubble is centered.
 - C. Push "LEFT" (Fig. 3F) and "RIGHT" (Fig. 3I) buttons as needed to raise the left and right sides of the coach respectively until level bubble is centered.
4. Turn Touch Pad "OFF" (Fig. 3A) to exit "MANUAL" mode; then turn it on again.
5. Now that the coach is leveled, press "FRONT" (Fig. 3C) 5 times.
6. Press "REAR" (Fig. 3H) 5 times. At this time all lights on the touch pad will flash with the exception of the ON/OFF indicator (Fig. 3E), it will remain solidly lit.
7. The touch pad is now in zero mode.
8. With the coach in level condition, simultaneously press the "RETRACT ALL JACKS" (Fig. 3D) button and the "AUTO" (Fig. 3J) button to store this as the Zero Level Point reference.
9. The "WAIT" light (Fig. 3K) will flash for approximately 5 seconds. After this, the control will emit an audible beep and revert back to normal operation mode. Zero Point calibration is now complete.

NOTE: You may also enter zero mode per above at anytime the system is in IDLE mode. The user then has control to extend any pair of jacks while in zero mode in order to position the vehicle properly prior to setting the zero point.

Manual Override - Jacks

In the event that the jacks will not extend or retract, the valves can be manually overridden by using a $\frac{5}{32}$ " or $\frac{5}{64}$ " hex wrench to turn the manual override clockwise on the valve. (Fig. 4). The leveling jacks can then be extended or retracted. Remember to turn the manual override completely counterclockwise (Fig. 5) until it will no longer turn, to close the valve after the jacks have been completely extended or retracted.

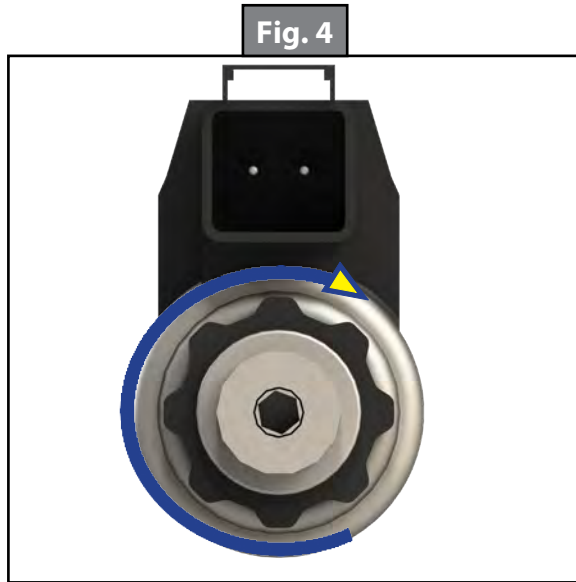

Clockwise for manual override

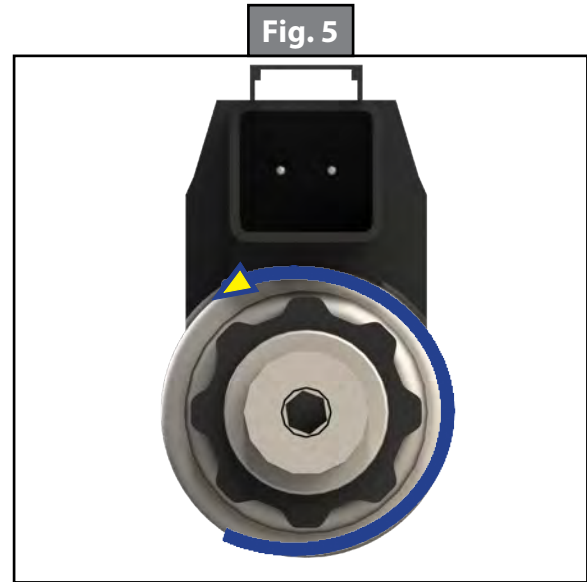

Counter-clockwise for normal operation

Manual Override - Power System

The Lippert Electronic Leveling System can be run with auxiliary power devices like electric drills, ratchet wrenches or cordless screwdrivers. In the event of electrical or system failure, this manual method of extending and retracting the jacks can be used. A standard handheld drill is all that is required.

1. Remove plastic cap (Fig. 6A).
2. Disconnect power cables on the motor.
3. Using a $\frac{1}{2}$ " socket, insert into auxiliary drive device, i.e. cordless or power drill. Insert socket onto coupler found under plastic cap (Fig. 7A).
4. Run drill in reverse or counterclockwise to retract jacks.

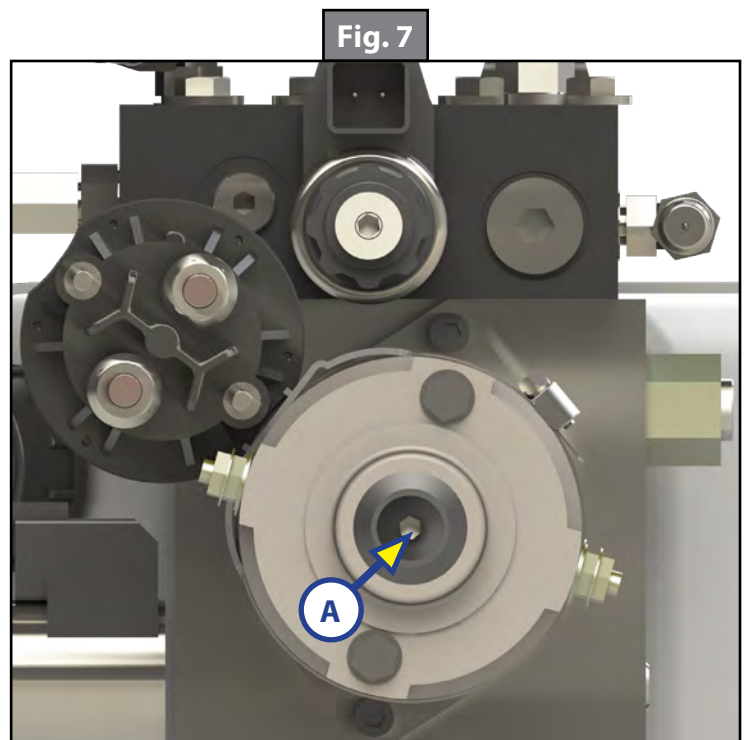
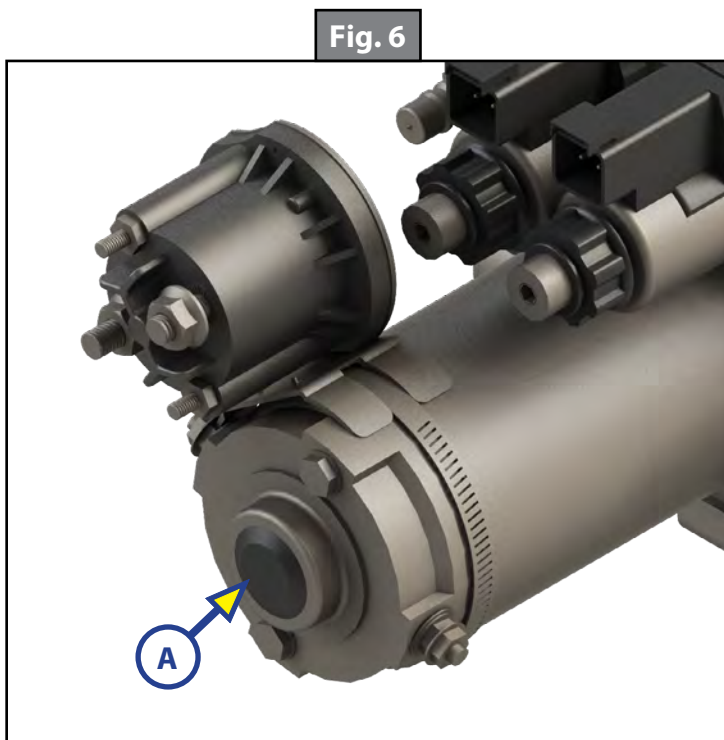

"Jacks Down" Alarm

The Lippert Electronic Leveling System is designed to sound an alarm and illuminate the control panel in the event of two (2) possible scenarios:

- A.** A "RETRACT" hose leaks.
- B.** The pressure holding the jacks in the retracted position falls to approximately 1500 psi to sound the alarm.

If the alarm sounds and the touchpad illuminates and flash while driving the vehicle:

- 1.** Immediately find an area to safely pull the vehicle off of the roadway.
- 2.** Set the PARKING BRAKE.
- 3.** Inspect all jacks hoses and check valve for leaks.

If no leaks are observed;

- 1.** Turn touchpad "ON."
- 2.** Push "RETRACT ALL JACKS" button.
- 3.** Wait until "JACKS DOWN" light and alarm are off.
- 4.** Inspect jacks. If jacks are retracted and no leaks are observed, vehicle can be driven.

If system is leaking or alarm does not subside after applying the above procedure, disconnect wires from pressure switch and proceed immediately to a service center. For prolonged travel to the service center, be sure to stop and check the disposition of the leveling jacks periodically to make sure they are not extending.

User Alarm Mode

If the alarm system detects that the park brake has been disengaged while at least one jack is not fully retracted and the sensor value changes in any axis more than a predefined amount, the panel will signal this error to the user. When in alarm mode, all LEDs will flash and the buzzer will beep. The status LEDs will show the system status. The system performs an automatic retract. No other features are available in this mode.

Low Voltage Signal

If LOW VOLTAGE light is on solid, it is an indication of a charging system problem. Turn ignition OFF and then back ON to reset system. If LOW VOLTAGE light persists, test battery under load at battery and at the motor solenoid on the pump unit. Check all power and ground connections at the battery, alternator and chassis.

Preventative Maintenance Procedures

1. Change fluid in RESERVOIR ONLY when contaminated.
 - A. Check fluid only when jacks are fully retracted.
 - B. Always fill the reservoir with the jacks in the fully retracted position. Filling reservoir when jacks are extended will cause reservoir to overflow into its compartment when jacks are retracted.
 - C. When checking fluid level, fluid should be within $\frac{1}{4}$ " of fill spout lip.
2. Check the fluid level every month.
3. Inspect and clean all Pump Unit electrical connections every 12 months. If corrosion is evident, spray unit with WD-40 or equivalent.
4. Remove dirt and road debris from jacks as needed.
5. If jacks are down for extended periods, it is recommended to spray exposed leveling jack rods with a silicone lubricant every three months for protection. If your coach is located in a salty environment, it is recommended to spray the rods every 4 to 6 weeks.

Latched Out Warning

⚠ WARNING

Your coach should be supported at both front and rear axles with jack stands before working underneath. Failure to do so may result in personal injury or death.

LATCHED ERROR mode is "Wait", "Jacks Down", "Park Brake", "Excess Slope" and "Low Voltage" lights flashing.

1. Battery voltage below 10.0V DC.
2. Retract time over 67 seconds in auto retract.
3. This is the only LATCHED ERROR mode.
4. To RESET, push all 4 diamond-shaped jack buttons at the same time (Fig. 8A).

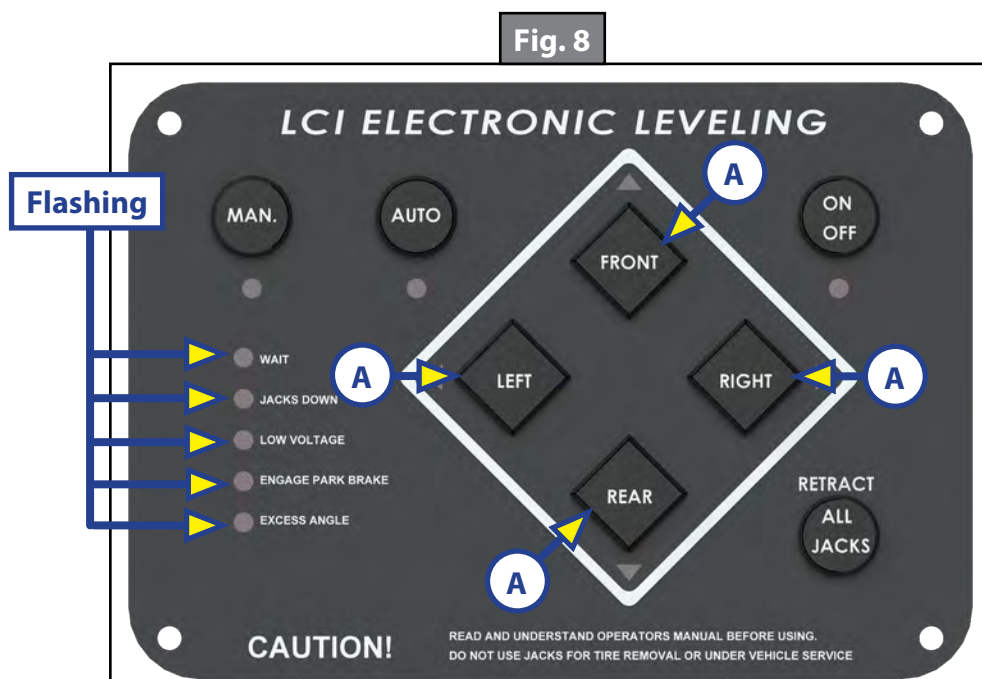

Troubleshooting Chart

What Is Happening?	Why?	What Should Be Done?
System will not turn on and ON/OFF indicator light does not illuminate.	Coach ignition not in RUN position.	Turn ignition to RUN position.
	Parking brake not set.	Set parking brake.
	Controls have been on for more than four minutes and have timed out.	Turn ignition off and then back on.
Touchpad turns on, but turns off when jack button is pushed.	Low voltage on battery.	Start coach to charge battery.
Touchpad turns on, coach will not auto level, JACKS DOWN light is on, jacks are retracted.	Faulty pressure switch or low pressure in system.	Press RETRACT ALL JACKS button on touchpad. If JACKS DOWN light remains on, contact Lippert Customer Care.
Jacks will not extend to ground, pump is running.	Little or no fluid in reservoir.	Fill reservoir with recommended ATF.
	Jack valve is inoperative.	Clean, repair or replace.
	Electronic signal is lost between controller and jack valves.	Trace wires for voltage drop or loss of signal. Repair or replace necessary wires or replace controller.
Any one or two jacks will not retract.	Hose damaged or disconnected.	Replace with new hose or reconnect hose.
	Return valve inoperative.	Replace inoperative return valve.
	Electronic signal is lost between controller and solenoid.	Test for voltage drop between controller and jack valve. Repair bad wiring or replace defective controller or valve.
JACKS DOWN light does not go out when all jacks are retracted.	Insufficient pressure in system.	Contact Lippert Customer Care.
	Retract pressure switch inoperable.	Check connection or replace.
Alarm sounds and JACKS DOWN light starts flashing while traveling; jacks are fully retracted.	Loss of pressure in leveling system.	Contact Lippert Customer Care.
	Retract pressure switch inoperable.	Check connection or replace.
Jack bleeds down after being extended.	Valve Manual Override open.	Close override.
Touchpad powers up; LOW VOLTAGE light flashes.	Engine not running.	Start coach engine.
Low voltage light on solid.	Charging system faulty.	Turn key OFF, then back ON again to reset. Check power and ground connections on battery, alternator and chassis.
No power to touchpad.	Tripped circuit breaker.	Reset breaker.
	Ignition not on.	Turn on.

Plumbing Diagram

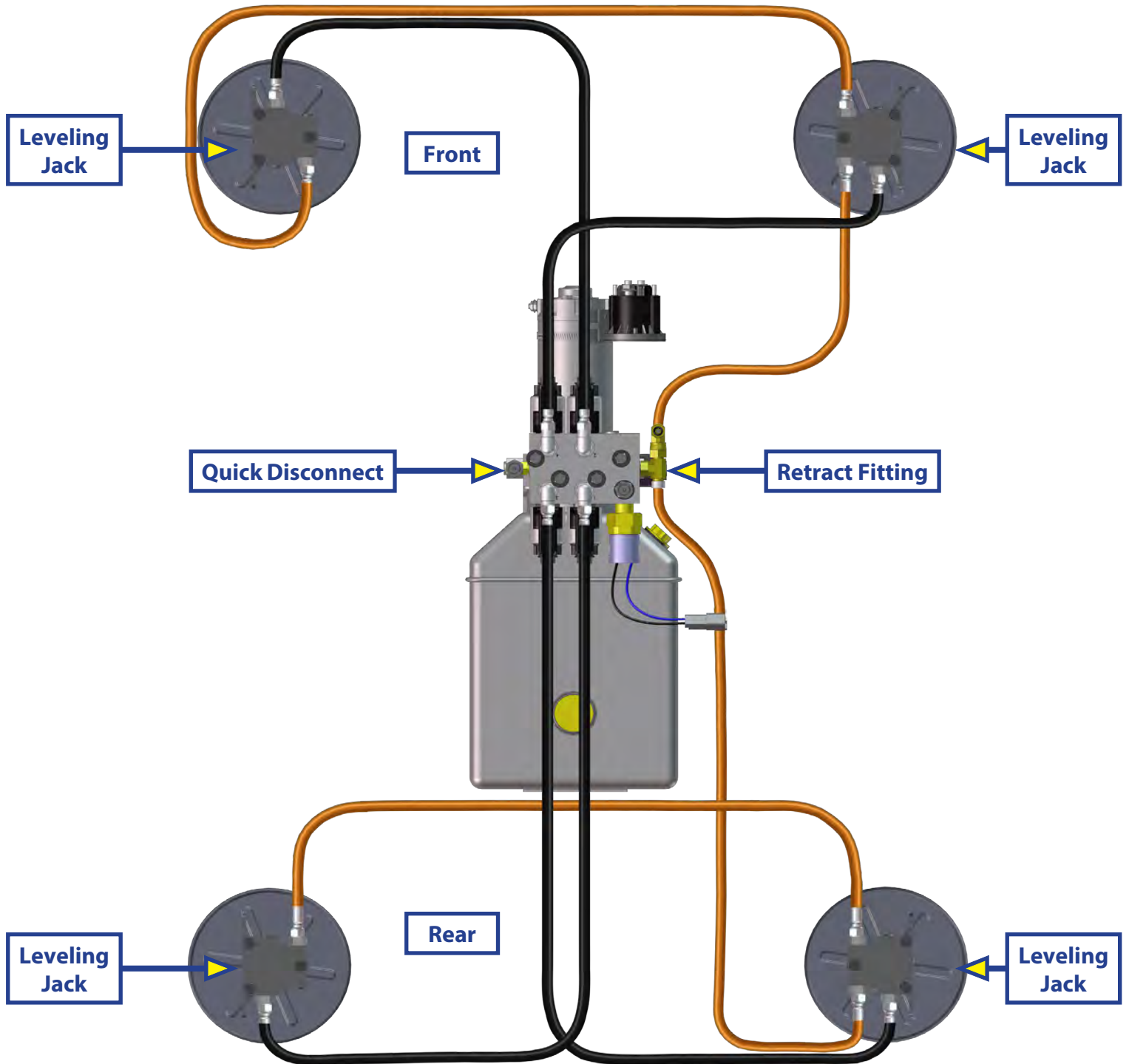

- Hoses will vary in length by coach model.
- Measure hose and consult Lippert Service. Hose Specs. 3000 p.s.i.; ½" in. I.D.
- Curbside Front - Black Hose - PURPLE Label & Wire
- Roadside Front - Black Hose - GREEN Label & Wire
- Curbside Rear - Black Hose - RED Label & Wire
- Roadside Rear - Black Hose - BLUE Label & Wire
- Return - Orange Hose
- PSI Switch - Yellow Wire into Blue PSI Wire

Wiring Diagrams

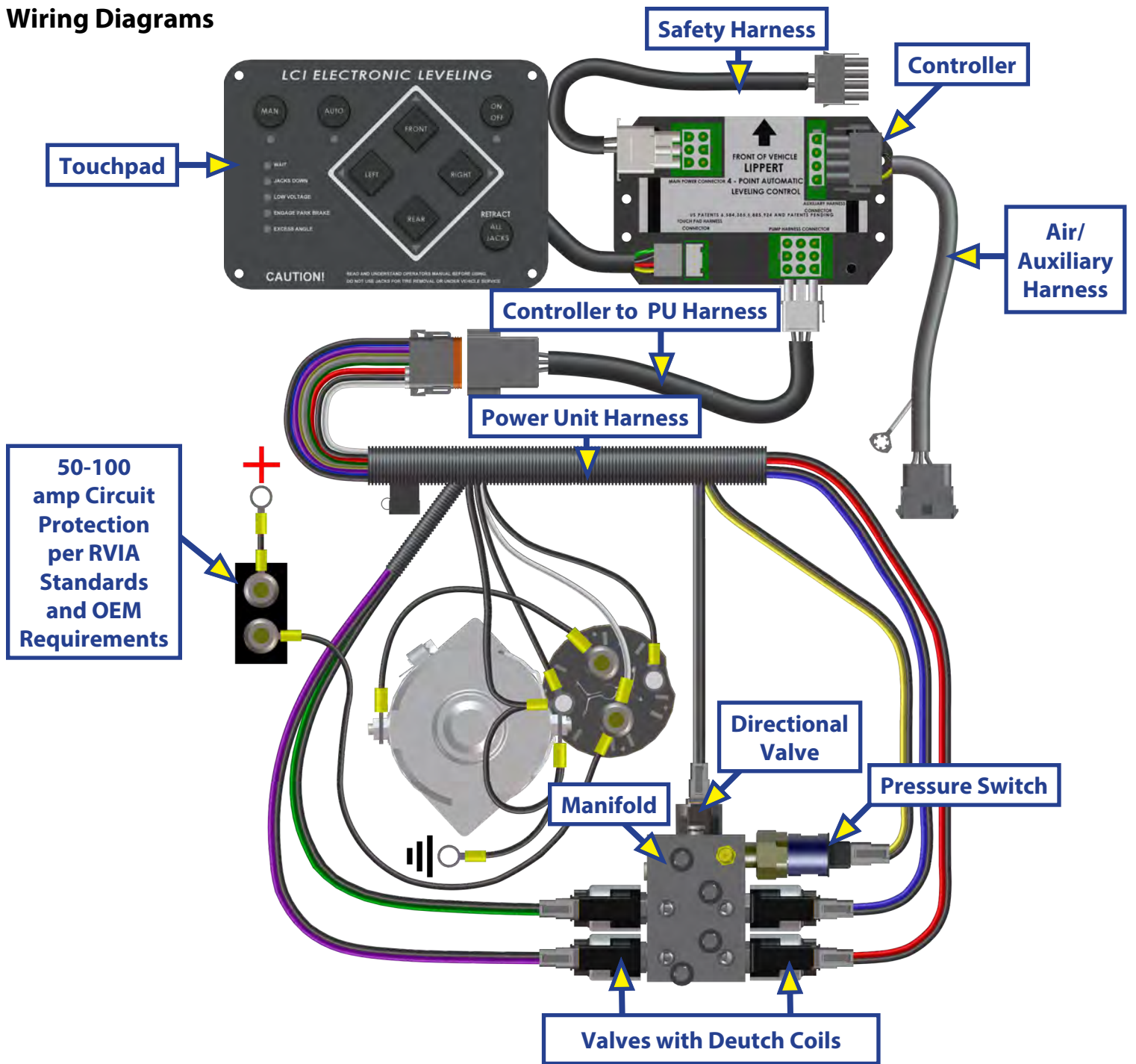

12-Pin Wire Harness

1. White (Chassis Power)
2. Black w/ White (Pump Solenoid)
3. Red (Curbside Rear Valve)
4. Green (Roadside Front Valve)
5. Yellow (PSI Switch)
6. Blue (Roadside Rear Valve)
7. Black (Ground)
8. Purple (Curbside Front Valve)
9. Gray (Pump Solenoid)
10. Aux
11. Aux
12. Aux

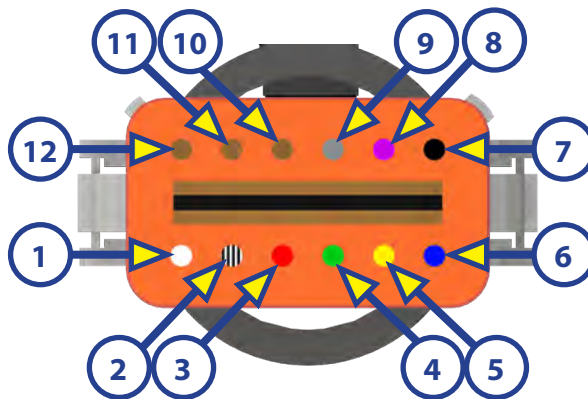



TITAN LEVELING SYSTEMS™
(4 VALVE/4 JACK)
OWNER'S MANUAL

TABLE OF CONTENTS

Introduction	2
Safety	3
Prior to Operation	4
LED Touchpad Controller Operation	4
Troubleshooting	8
Manual Override - Jacks.....	8
Manual Override - Power System.....	8
Audible Alarm Modes.....	9
Preventative Maintenance Procedures.....	9
Fluid Recommendation.....	9
Level Zero Point Calibration.....	10
Solutions to Possible System Errors.....	13
Optional Crossbar Lights Wiring Diagram	14
Hydraulic Plumbing Diagram (Sprinter)	15
Hydraulic Plumbing Diagram (Transit, E450, Chevy 5500)	16
LED Wiring Diagram	17

Introduction

The Titan Leveling System™ is a hydraulic leveling system which includes four points of contact utilizing four jacks and a four-valve hydraulic system. A 12V DC electric motor drives a hydraulic pump that moves fluid through a system of hoses, fittings and jacks to level and stabilize the coach. Mechanical portions of the hydraulic leveling system are replaceable. This system is compatible with the Sprinter, Transit, and E450 Chassis. Contact Lippert to obtain replacement parts.

Additional information about this product can be obtained from lci1.com/support or by downloading the free LippertNOW app. The app is available on Apple App Store® for iPhone® and iPad® and also on Google Play™ for Android™ users.

Apple App Store®, iPhone®, and iPad® are registered trademarks of Apple Inc.

Google Play™ and Android™ are trademarks of Google Inc.

For information on the assembly or individual components of this product, please visit:

<https://support.lci1.com/lippert-motorized-titan-leveling-system>

NOTE: Images used in this document are for reference only when assembling, installing and/or operating this product. Actual appearance of provided and/or purchased parts and assemblies may differ.

Safety

Read and understand all instructions before installing or operating this product. Adhere to all safety labels.

This manual provides general instructions. Many variables can change the circumstances of the instructions, i.e., the degree of difficulty, operation and ability of the individual performing the instructions. This manual cannot begin to plot out instructions for every possibility, but provides the general instructions, as necessary, for effectively interfacing with the device, product or system. Failure to correctly follow the provided instructions may result in death, serious personal injury, severe product and/or property damage, including voiding of the Lippert limited warranty.

WARNING

The "WARNING" symbol above is a sign that a procedure has a safety risk involved and may cause death or serious personal injury if not performed safely and within the parameters set forth in this manual.

WARNING

Failure to follow instructions provided in this manual may result in death, serious personal injury and/or severe product and property damage, including voiding of the component warranty.

WARNING

During servicing make sure that the coach is supported according to the manufacturer's recommendation. Lift the coach by the frame and never the axle or suspension. Do not go under the coach unless it is properly supported. Unsupported coaches can fall causing death or personal injury or product or property. Use proper personal protective equipment damage.

CAUTION

The "CAUTION" symbol above is a sign that a safety risk is involved and may cause personal injury and/or product or property damage if not safely adhered to and within the parameters set forth in this manual.

CAUTION

Always wear eye protection when performing service, maintenance or installation procedures. Other safety equipment to consider would be hearing protection, gloves and possibly a full face shield, depending on the nature of the task.

CAUTION

Moving parts can pinch, crush, or cut. Keep clear and use caution

Prior to Operation

The leveling system shall only be operated under the following conditions:

1. The coach is parked on a reasonably level surface, engine running.
2. The coach "parking brake" is engaged.
3. The coach transmission should be in the park position.
4. Be sure to keep hands and other body parts clear of fluid leaks. Oil leaks in the Lippert Leveling System may be under high pressure and can cause serious skin penetrating injuries.
5. Never lift the coach completely off the ground. Lifting the coach so the wheels are not touching ground will create an unstable and unsafe condition.

⚠ WARNING

Lifting all wheels off the ground may result in serious personal injury or death.

LED Touchpad Controller Operation

NOTE: The LED Touchpad Controller is only ON while the coach ignition is ON, no operation of leveling will be allowed without ignition source. Parking Brake **MUST** be engaged for the system to operate.

1. Figure 1 is the default screen when coach ignition is ON and assigned to the "Home" icon (Fig. 1A).
2. Figure 2 is assigned to "Menu" icon (Fig. 2A).
 - A. (Fig. 2B) MANUAL MODE ability to extend jacks in pairs.
 - B. (Fig. 2C) CONNECT APP with phone Bluetooth on, click button to search on phone for "Auto Level, Titan Leveling Systems" or similar.
 - C. (Fig. 2D) CALIBRATION is a required step to program the control's orientation and define a level plane. Initial calibration will be set by OEM but operator may perform calibration again at a later date to ensure the system is at a level plane.
 - D. (Fig. 2E) JACK LIGHTS on/off button, turns on all LED lights located on the front and rear crossbars, close to each of the jacks. Lights are optional and this button may not be used.

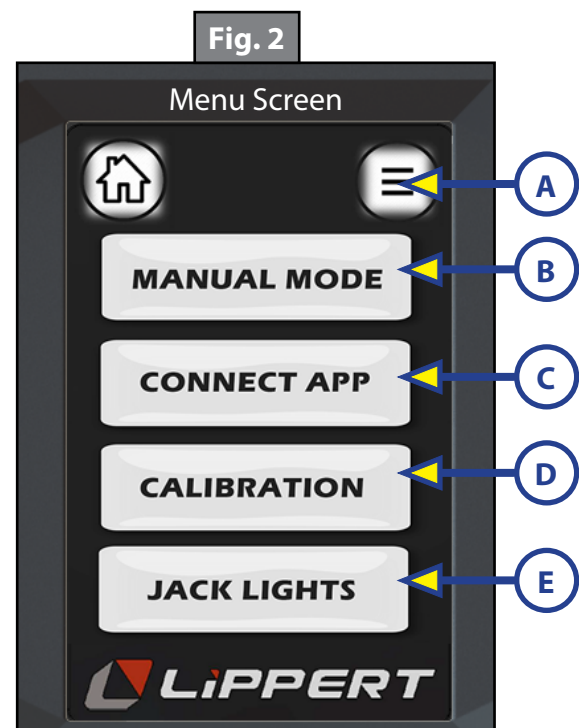
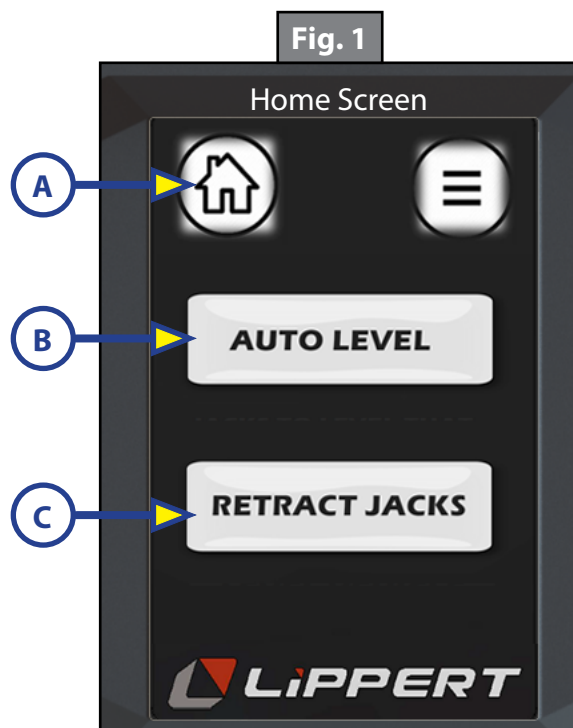

- Figure 4 is assigned to "Manual Mode" button from menu screen (Fig. 2B). Each button, ex. Extend Front (Fig. 4A) is a button that operates both front jacks. Each button is a pair of jacks and only extends the jacks.
- Figure 3 is the screen displayed during the leveling process.

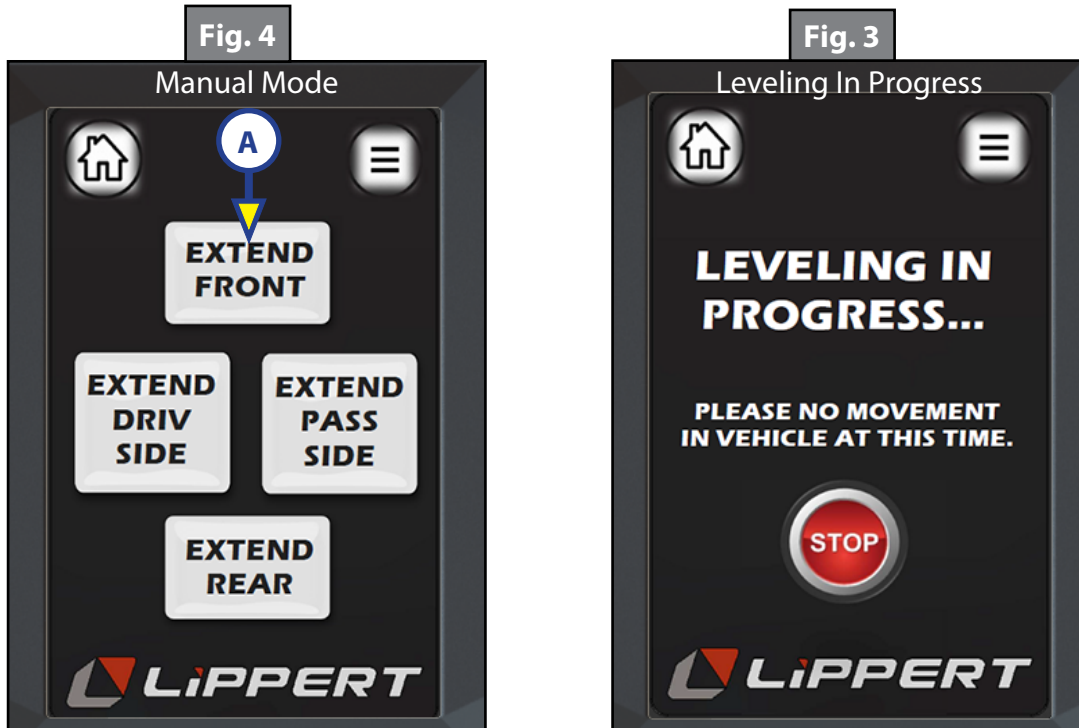

- During the, "Auto Level" process, (Fig. 1B), control sensed movement in the coach during leveling process, too much time has passed or if control was calling to extend pair of jacks but saw zero movement (angle change) meaning the cylinders have reached full stroke, or coach is parked on too great of an incline (typically over 6 degrees) and cannot complete level process. The "Leveling Error" screen (Fig. 5) will appear. Press Home (Fig. 5A) or Menu (Fig. 5B) icons to get out of this page.
- During the, "Retract Jacks" (Fig. 1C), or in "Manual Mode", (Fig. 2B), Figure 6, "Jacks Are Retracting" screen is displayed.

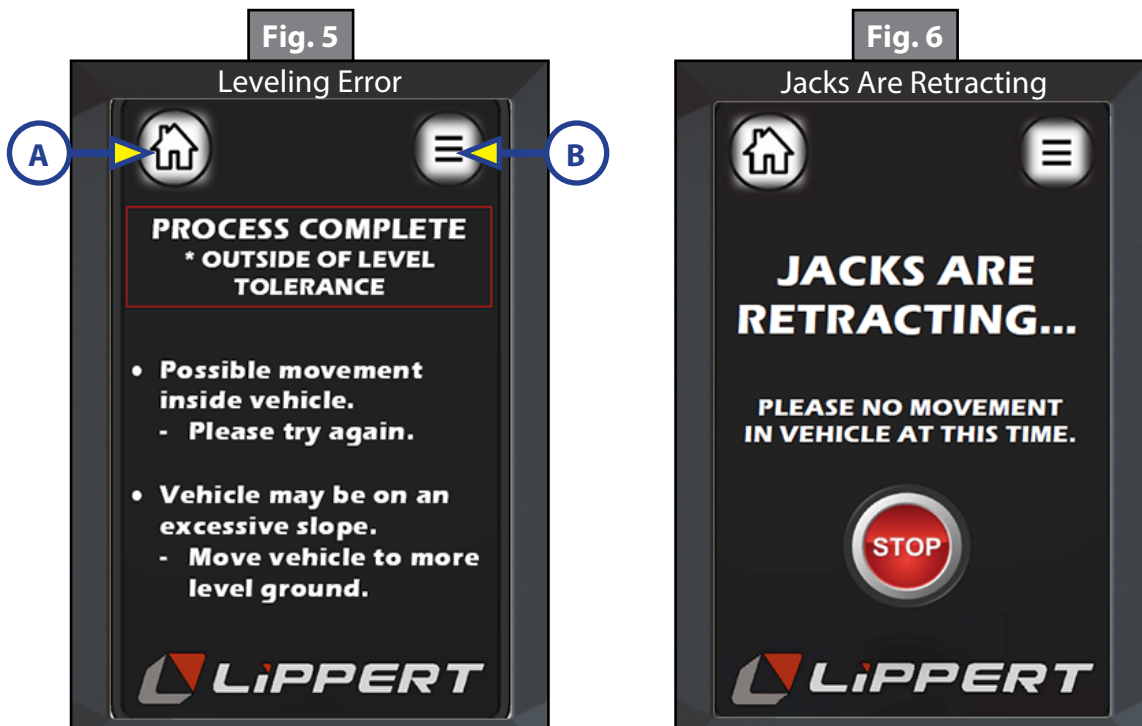

7. Figure 7, "Parking Brake Error", will appear when no parking brake signal is received and there is no pressure switch signal indicating jacks are still retracted. Screen prompted before auto level and manual mode functions. Screen prompted for five seconds, then returns to home screen (Fig. 1). If jacks are extended and parking brake signal is lost, jacks will automatically retract.
8. Figure 8, "Insufficient Voltage", screen may be prompted before or during "Auto Level", "Retract Jacks" or "Manual Mode" functions. This screen is prompted when the control is receiving less than 10.7 volts.

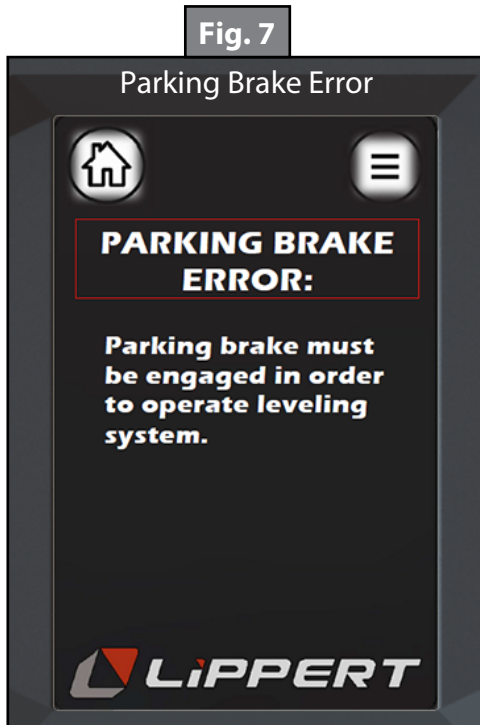

9. "Retract Error" screen (Fig. 9) will appear with ignition on and touchpad on or in "sleep" mode (display off, power to control still on). If the control receives signal from the pressure switch (meaning the internal pressure of the hydraulic system has dropped below 2,150 psi, connection lost from pressure switch to control) the control enters retract all mode. If pressure switch does not open back up after 10 seconds, the audible alarm may be prompted (2 seconds on, two seconds off, 70-85 decibels), jacks will stop retracting and this screen will be displayed. Alarm will run until coach ignition is off or pressure switch opens up indicating that optimal pressure is reached. Home (Fig. 9A) or Menu (Fig. 9B) icons can be pressed to silence the alarm. **DO NOT** ignore this alarm. There may be a jack down or component failure, possibly making it dangerous to drive. Operator can use the home or menu icon and reach "retract jacks" function.

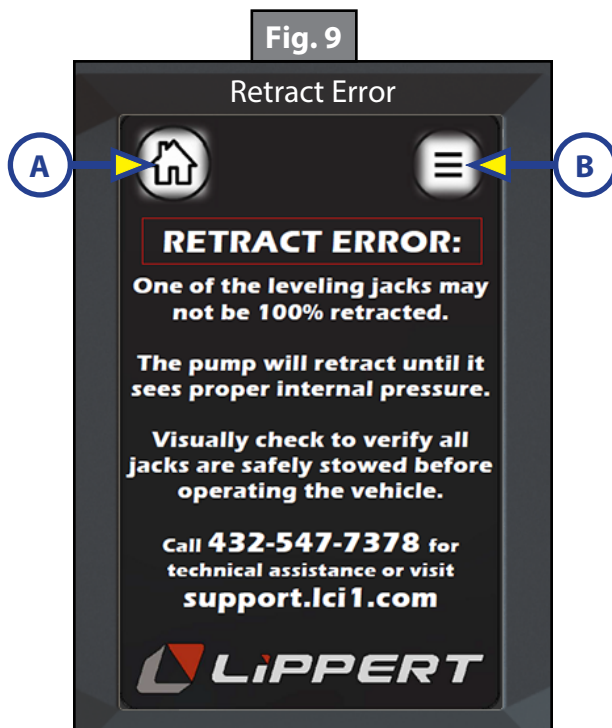

10. Figure 10, "Level Success!" screen is prompted after auto level feature has successfully completed. Accompanied by an audible chime (3 seconds long). Screen stays active for 5-10 seconds, then returns to home screen (Fig. 1).

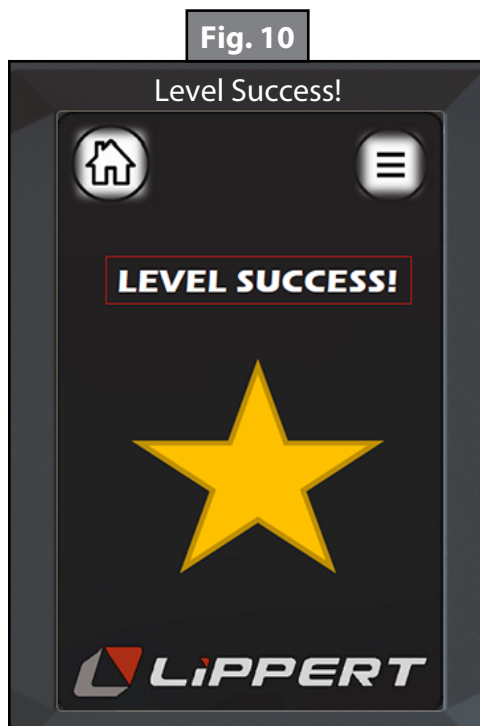

Troubleshooting

Manual Override - Jacks

In the event that the jacks will not extend or retract, the valves can be manually overridden by using a $\frac{5}{32}$ " or $\frac{5}{64}$ " hex wrench to turn the manual override clockwise on the valve (Fig. 11). The leveling jacks can then be extended or retracted. Remember to turn the manual override completely counterclockwise (Fig. 12) until it will no longer turn to close the valve after the jacks have been completely extended or retracted.

Fig. 11

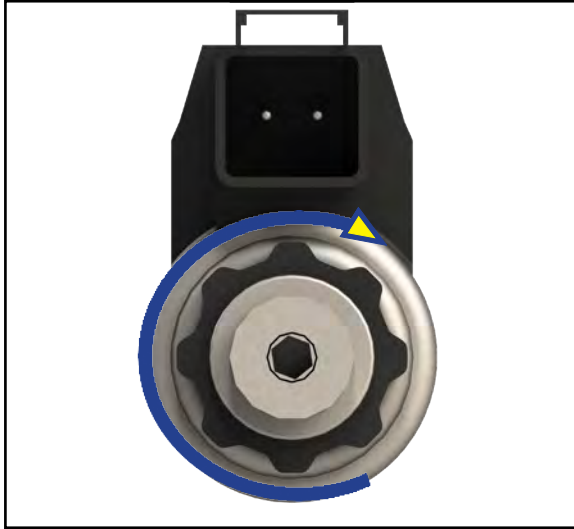

Clockwise for manual override

Fig. 12

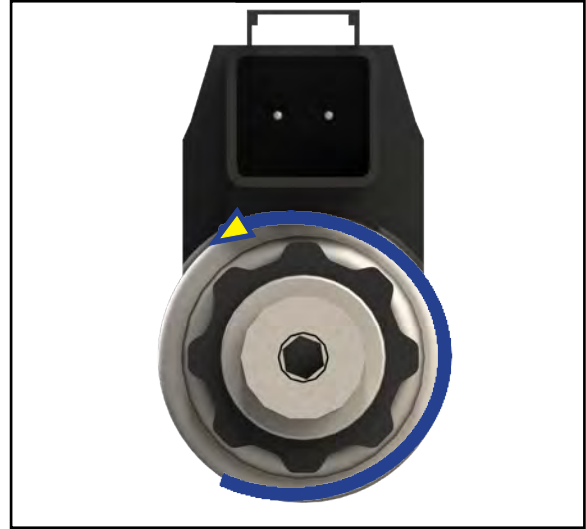

Counter-clockwise for normal operation

Manual Override - Power System

The Lippert Electronic Leveling System can be run with auxiliary power devices including electric drills, ratchet wrenches or cordless screwdrivers. In the event of electrical or system failure, this manual method of extending and retracting the jacks can be used. A standard handheld drill is all that is required.

1. Remove plastic cap (Fig. 13A).
2. Disconnect power cables on the motor.
3. Using a $\frac{1}{2}$ " socket, insert into auxiliary drive device, i.e. cordless or power drill. Insert socket onto coupler found under plastic cap (Fig. 14A).
4. Run drill in reverse or counterclockwise to retract jacks.

Fig. 13

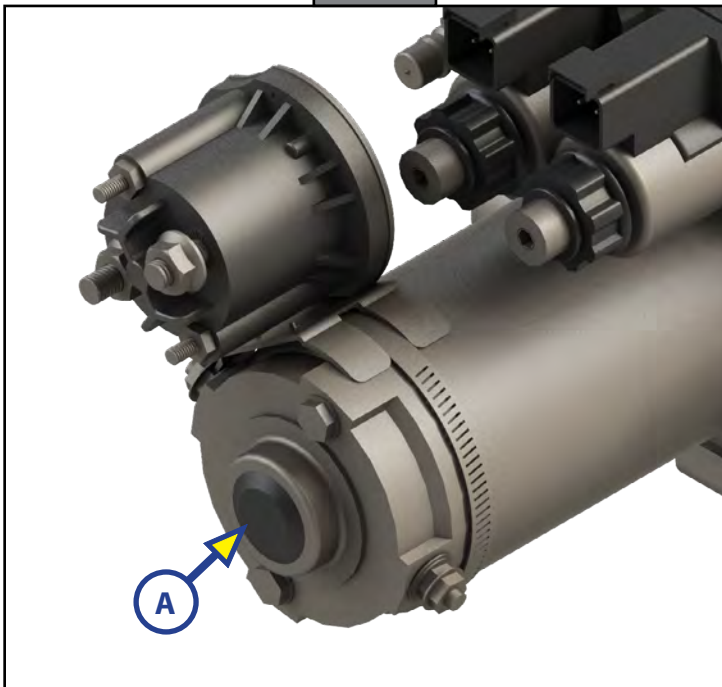
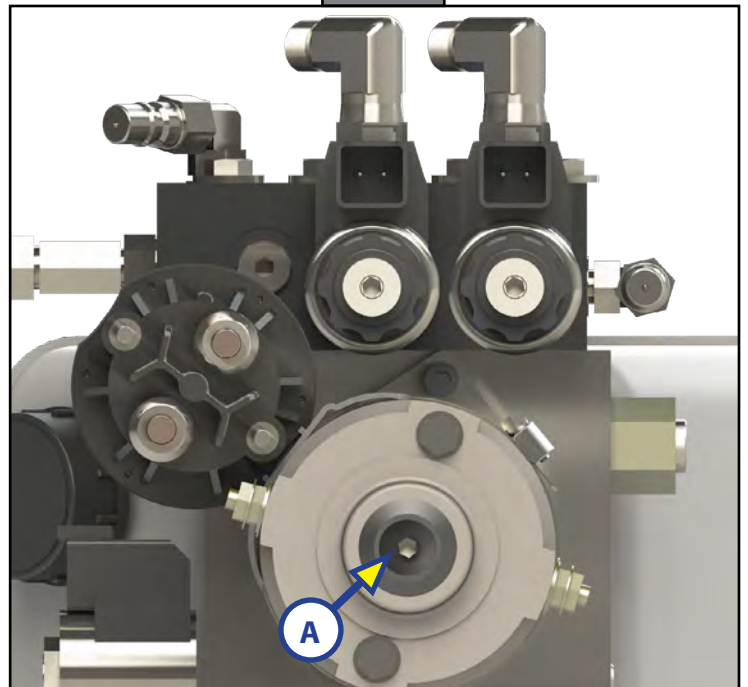

Fig. 14



Audible Alarm Modes

- Parking brake alarm, enabled from software while ignition is on, display is in sleep mode or on, related to loss of signal from parking brake (user dis-engages parking brake) while pressure switch signal is received (jacks are down). Alarm to sound two seconds ON, two seconds OFF, repeat until ignition off or signal is received from parking brake or signal is lost from pressure switch (indicating jacks retracted) for software to shut off alarm.
- Leveling complete chime, small collection of chimes or light beeps to indicate to user that leveling has successfully completed, can be tied to "Leveling Success!" screen. Only few seconds long.

Preventative Maintenance Procedures

1. Change fluid in RESERVOIR ONLY when contaminated.
 - A. Check fluid only when jacks are fully retracted.
 - B. Always fill the reservoir with the jacks in the fully retracted position. Filling reservoir when jacks are extended will cause reservoir to overflow into its compartment when jacks are retracted.
 - C. When checking fluid level, fluid should be within $\frac{1}{4}$ " of fill spout lip.
2. Check the fluid level every month.
3. Inspect and clean all pump electrical connections every 12 months. If corrosion is evident, spray coach with WD-40 or equivalent.
4. Remove dirt and road debris from jacks as needed.
5. If jacks are down for extended periods, it is recommended to spray exposed leveling jack rods with a silicone lubricant every three months for protection. If your coach is located in a salty environment, it is recommended to spray the rods every 4 to 6 weeks.

Fluid Recommendation

ATF with Dexron III® or Mercon 5® or a blend of both is recommended by Lippert.

Type "A" Automatic Transmission Fluid (ATF) is utilized and approved.

Hydraulic system operation in climates at or below 40 degrees F (4 degrees C) may result in the following:

- Slow operation during extension/retraction
- Incomplete retraction of jacks during Auto Retract procedure

For a list of approved fluid specifications, see [TI-188](#).

Level Zero Point Calibration

The Zero Point Calibration has been set by the RV manufacturer and verified by the RV dealer. If a new zero point is desired, proceed with this section. The "Zero Point" is the programmed point that the trailer will return to each time the Auto Level feature is used. The "Zero Point" must be programmed prior to using the Auto Level feature to ensure the proper operation of the system. This mode is enabled by performing the following sequence:

NOTE: Parking brake **MUST** be **ON** in order to operate the leveling system.

NOTE: The LED touchpad controller is only ON while the coach ignition is ON, no operation of leveling is allowed without the ignition source. Once power is on, the LED touchpad controller will illuminate.

1. Go to the Menu button (Fig. 15A) and select the Calibration button (Fig. 15B).
2. Select the arrow on the touchpad that is the direction of the display of the touchscreen is facing related to the coach (Fig. 16).

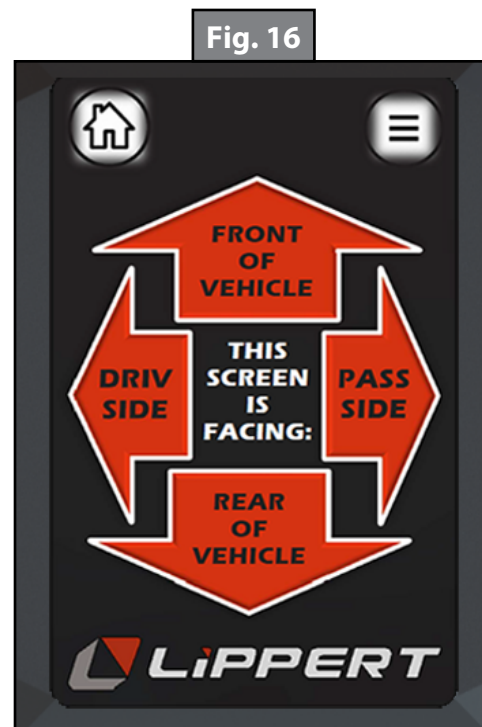
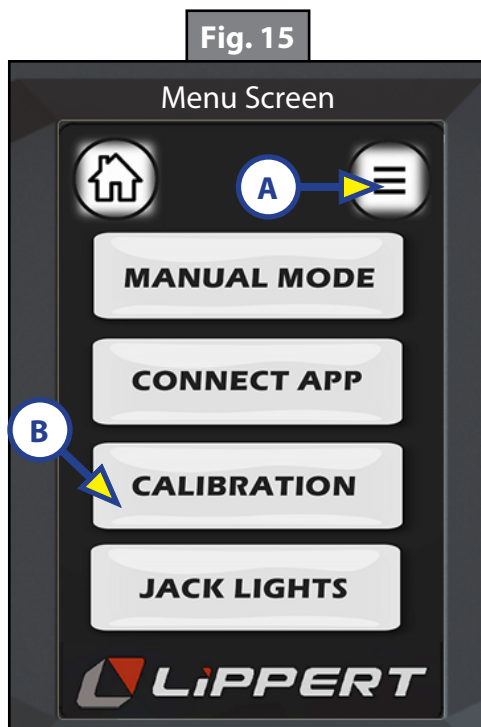

3. Follow the directions on the next screen (Fig. 17) to calibrate the LED touchpad controller. Place a level on the floor of the coach to ensure a level reference point in the coach. Press "LEVEL VEHICLE" on the touchpad.

Fig. 17

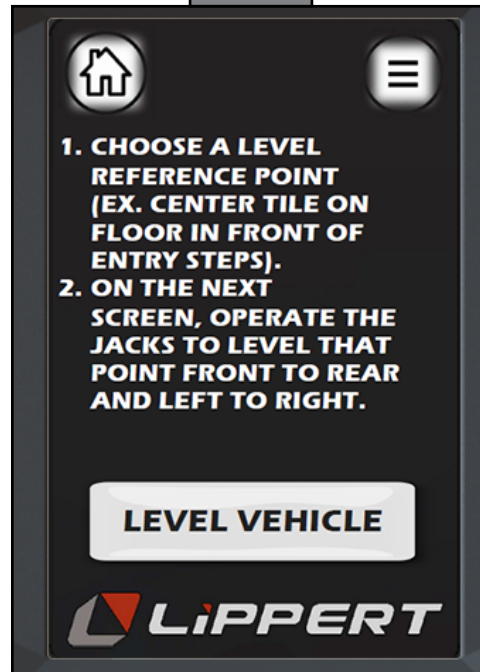

4. The next screen that follows (Fig. 18) shows four extend buttons that activate each pair of valves, directional control valve and solenoid. The "CONFIRM LEVEL" button is a latching button that zeros out the control accelerometer and stores that exact position as level. After the initial calibration, when the user presses "AUTO LEVEL", the control recognizes that position as level and will bring the coach to that position.
5. Level the coach in the manual "CALIBRATION" mode by using a carpenter's level on the floor. Level front to rear and then left to right.
 - A. Push the "EXTEND FRONT" (Fig. 18A) button until jacks contact the ground and lift the front of the coach 1-2 inches.

Fig. 18

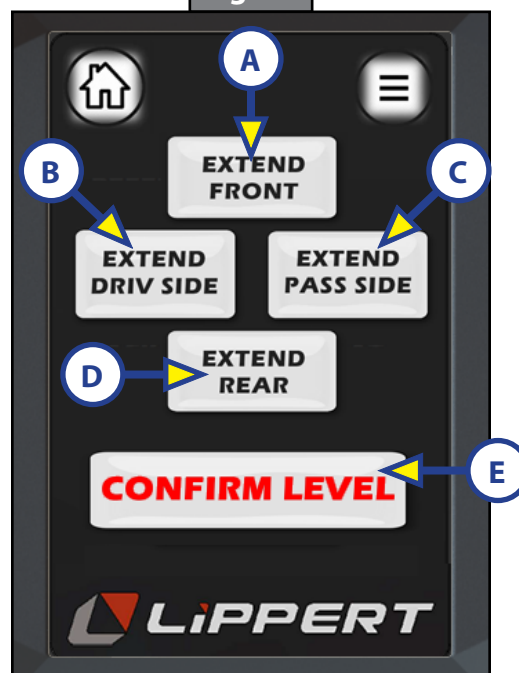

- A. Push "EXTEND REAR" (Fig. 18D) button until jacks contact the ground and lift rear of coach. Continue to use EXTEND REAR and EXTEND FRONT buttons until the carpenter's level bubble is centered.
- B. Push "EXTEND DRIV SIDE" (Fig. 18B) and "EXTEND PASS SIDE" (Fig. 18C) buttons until level bubble is centered.

NOTE: Wait 10 seconds after operating jacks to ensure vehicle is completely still before pressing CONFIRM LEVEL.

6. With the coach leveled, press "CONFIRM LEVEL" (Fig. 18E).
7. The touchpad is now in zero mode. If the coach has come out of its level condition, it can be reset into level condition by following the procedure outlined in step 3.

NOTE: During the "auto level" process, if too much time has passed (180 seconds) or if control was calling to extend a pair of jacks but saw zero movement (angle change) meaning the cylinders have reached full stroke, or coach is parked on too great of an incline (typically over 6 degrees) and cannot complete level process. A "LEVELING ERROR" screen (Fig. 19) will appear. Press Home (Fig. 19A) or Menu (Fig. 19B) icons to get out of this page.

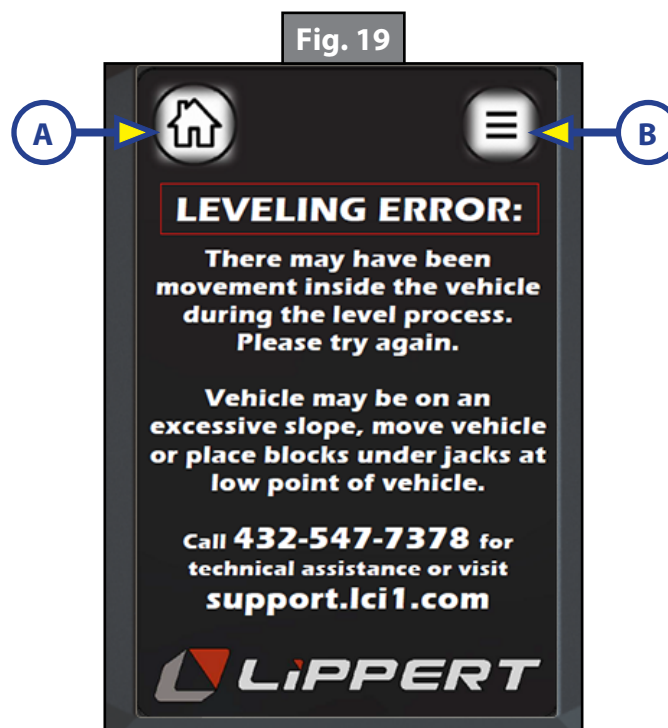

Solutions to Possible System Errors

What Is Happening?	Why?	What Should Be Done?
System will not turn on.	Coach ignition not in RUN position.	Turn ignition to RUN position.
	Parking brake not set.	Set parking brake.
	Controls have been on for more than four minutes and have timed out.	Tap screen or turn ignition off and then back on.
Touchpad turns on, but turns off when a jack button is pushed.	Low voltage on battery.	Start coach to begin charging battery.
		Plug vehicle in to charge house battery.
Touchpad turns on, coach will not auto level.	Faulty pressure switch or low pressure in system.	Check parking brake is engaged.
		Re-calibrate level position.
Jacks will not extend to ground, pump is running.	Little or no fluid in reservoir.	Fill reservoir with recommended ATF.
	Jack valve is inoperative.	Clean, repair or replace.
	Electronic signal is lost between controller and jack valves.	Trace wires for voltage drop or loss of signal. Repair or replace necessary wires or replace controller.
Any one or two jacks will not retract.	Hose damaged or disconnected.	Replace with new hose or reconnect hose.
	Return valve inoperative.	Replace inoperative return valve.
	Electronic signal is lost between controller and solenoid.	Test for voltage drop between controller and jack valve. Repair bad wiring or replace defective controller or valve.
Jack bleeds down after being extended.	Valve manual override open.	Close override.
No power to touchpad.	Tripped circuit breaker.	Reset breaker.
	Ignition not on.	Turn on.

Optional Crossbar Lights Wiring Diagram

Fig. 20

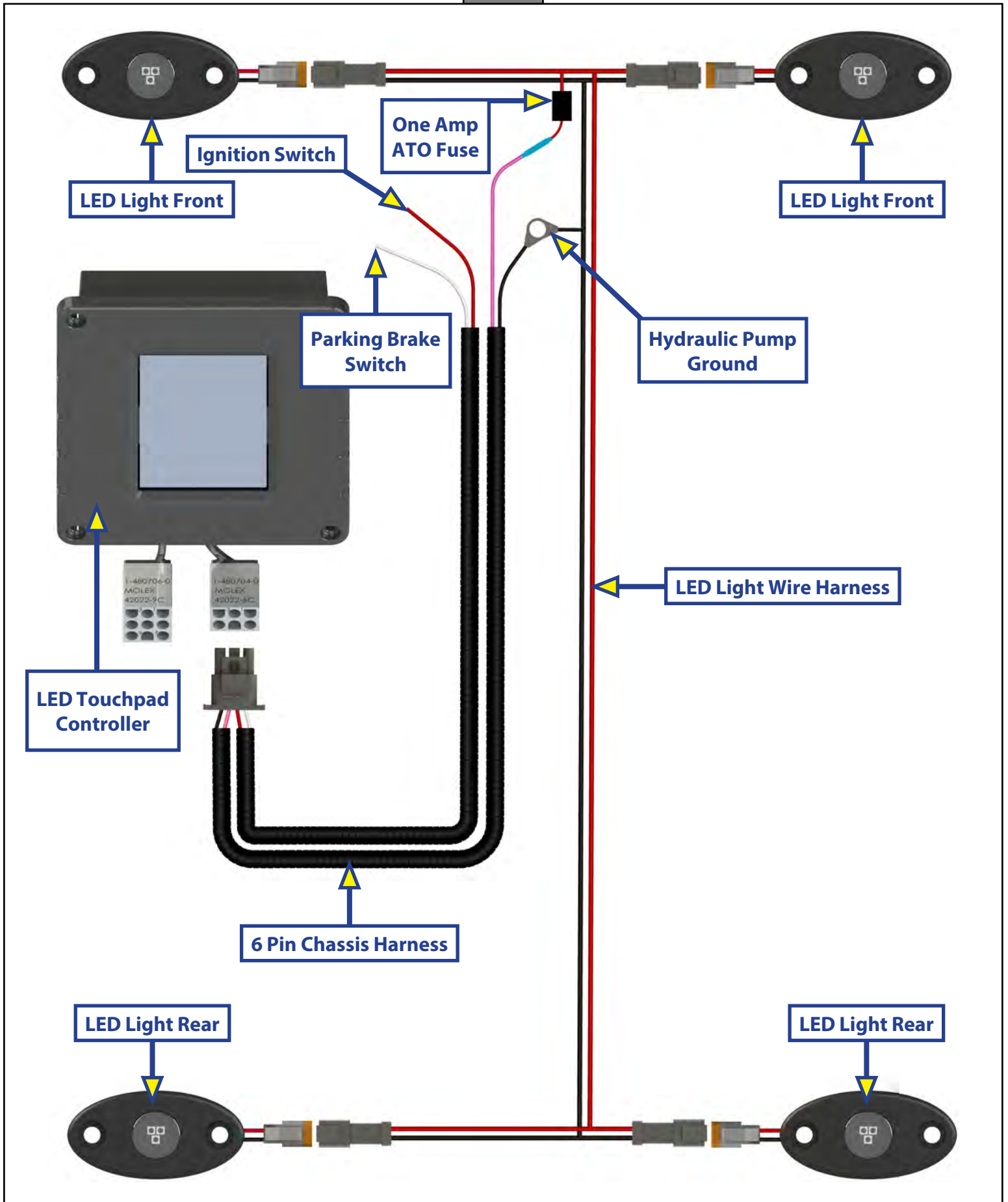

Hydraulic Plumbing Diagram (Sprinter)

Fig. 21

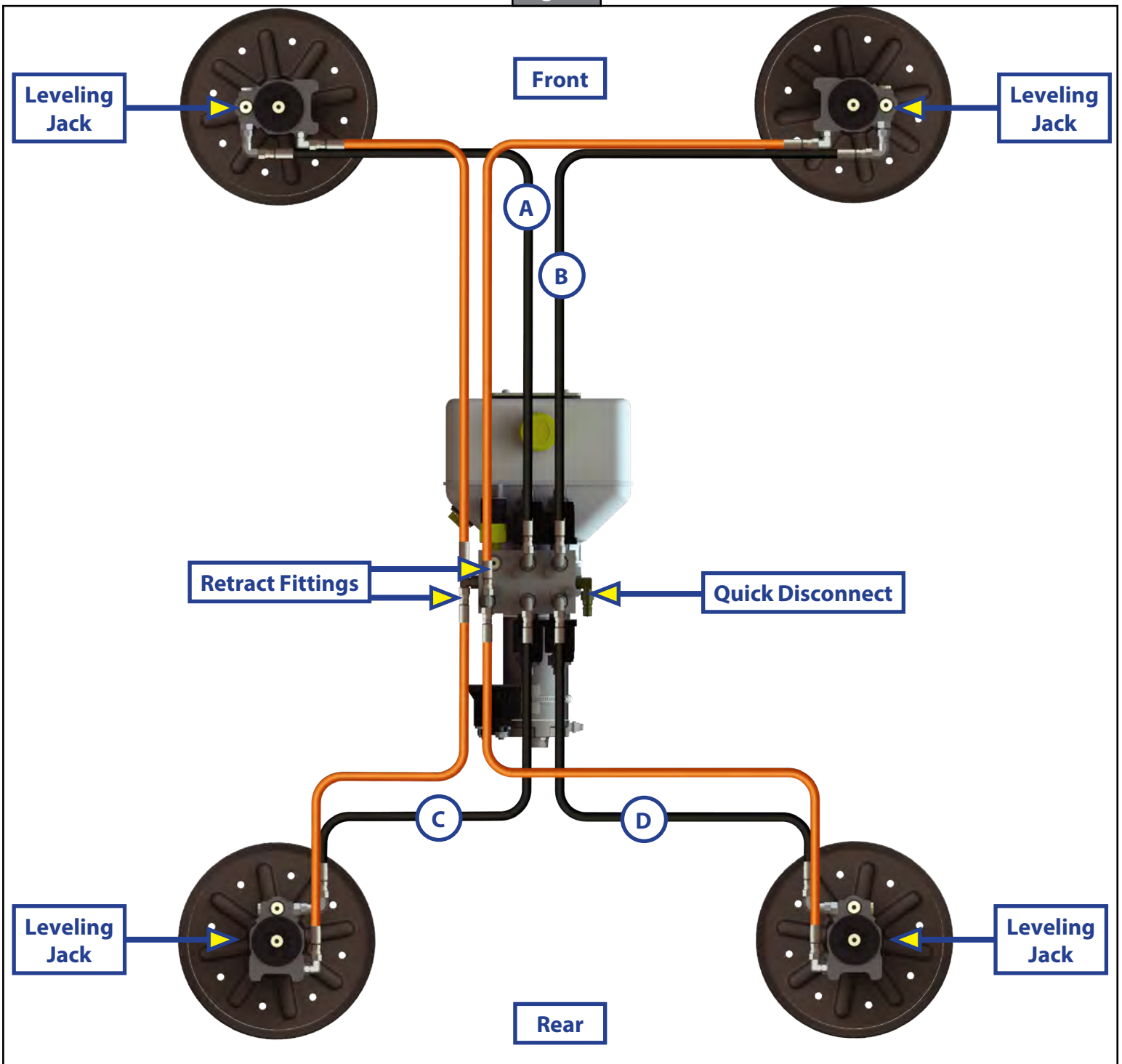

- Hoses will vary in length by coach model.
- Measure hose and consult Lippert Service. Hose Specs. 3000 p.s.i.; 1/4" in. I.D.
- Curbside Front (Fig. 21B) - Black Hose - PURPLE Label & Wire
- Roadside Front (Fig. 21A) - Black Hose - GREEN Label & Wire
- Curbside Rear (Fig. 21D) - Black Hose - RED Label & Wire
- Roadside Rear (Fig. 21C) - Black Hose - BLUE Label & Wire
- Return/Retract - Orange Hose
- PSI Switch - Yellow Wire into Blue PSI Wire

Hydraulic Plumbing Diagram (Transit, E450, Chevy 5500)

Fig. 22

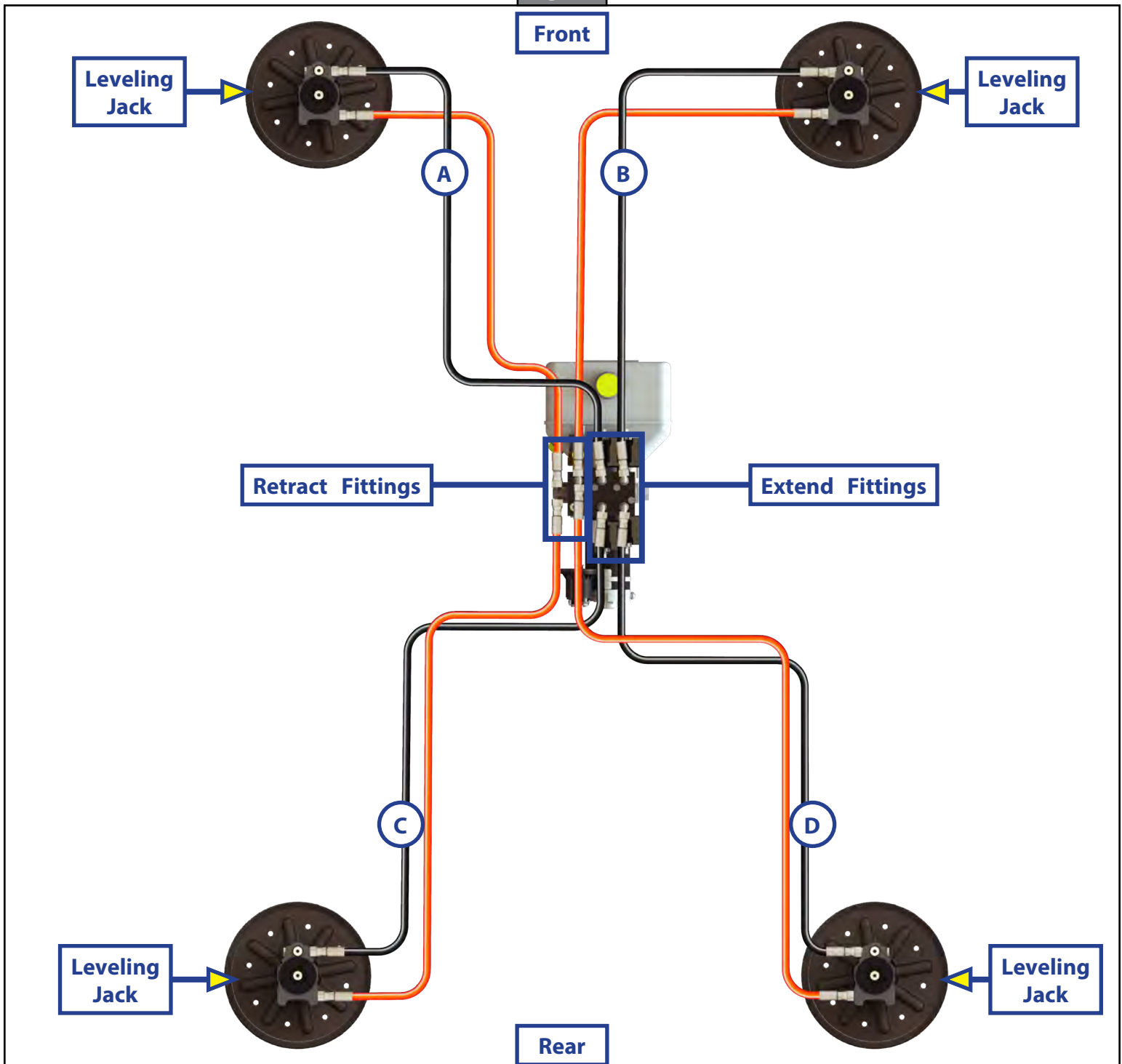

- Hoses will vary in length by coach model.
- Measure hose and consult Lippert Service. Hose Specs. 3000 p.s.i.; 1/4" in. I.D.
- Curbside Front (Fig. 22B) - Black Hose - PURPLE Label & Wire
- Roadside Front (Fig. 22A) - Black Hose - GREEN Label & Wire
- Curbside Rear (Fig. 22D) - Black Hose - RED Label & Wire
- Roadside Rear (Fig. 22C) - Black Hose - BLUE Label & Wire
- Return/Retract - Orange Hose
- PSI Switch - Yellow Wire into Blue PSI Wire

LED Wiring Diagram

Fig. 23

6-Pin Chassis Harness

- 1. White (Parking Brake Ground)
- 2. Pink (LED Power)
- 3. Black (LED Ground)
- 4. AUX
- 5. Red (Ignition Source 12V)
- 6. AUX

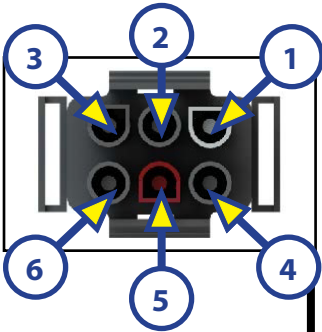

9-Pin Power Unit Wire Harness

- 1. White (Control 12V Power)
- 2. Black w/ White (Pump Solenoid)
- 3. Red (Curbside Rear Valve)
- 4. Green (Roadside Front Valve)
- 5. Yellow (PSI Switch)
- 6. Blue (Roadside Rear Jack Valve)
- 7. Brown (Ground)
- 8. Purple (Curbside Front Jack Valve)
- 9. Gray (Directional Valve)

12-Pin Power Unit Wire Harness

- 1. White (Chassis Power)
- 2. Black w/ White (Pump Solenoid)
- 3. Red (Curbside Rear Valve)
- 4. Green (Roadside Front Valve)
- 5. Yellow (PSI Switch)
- 6. Blue (Roadside Rear Jack Valve)
- 7. Black (Ground)
- 8. Purple (Curbside Front Jack Valve)
- 9. Gray (Directional Valve)
- 10. Aux
- 11. Aux
- 12. Aux

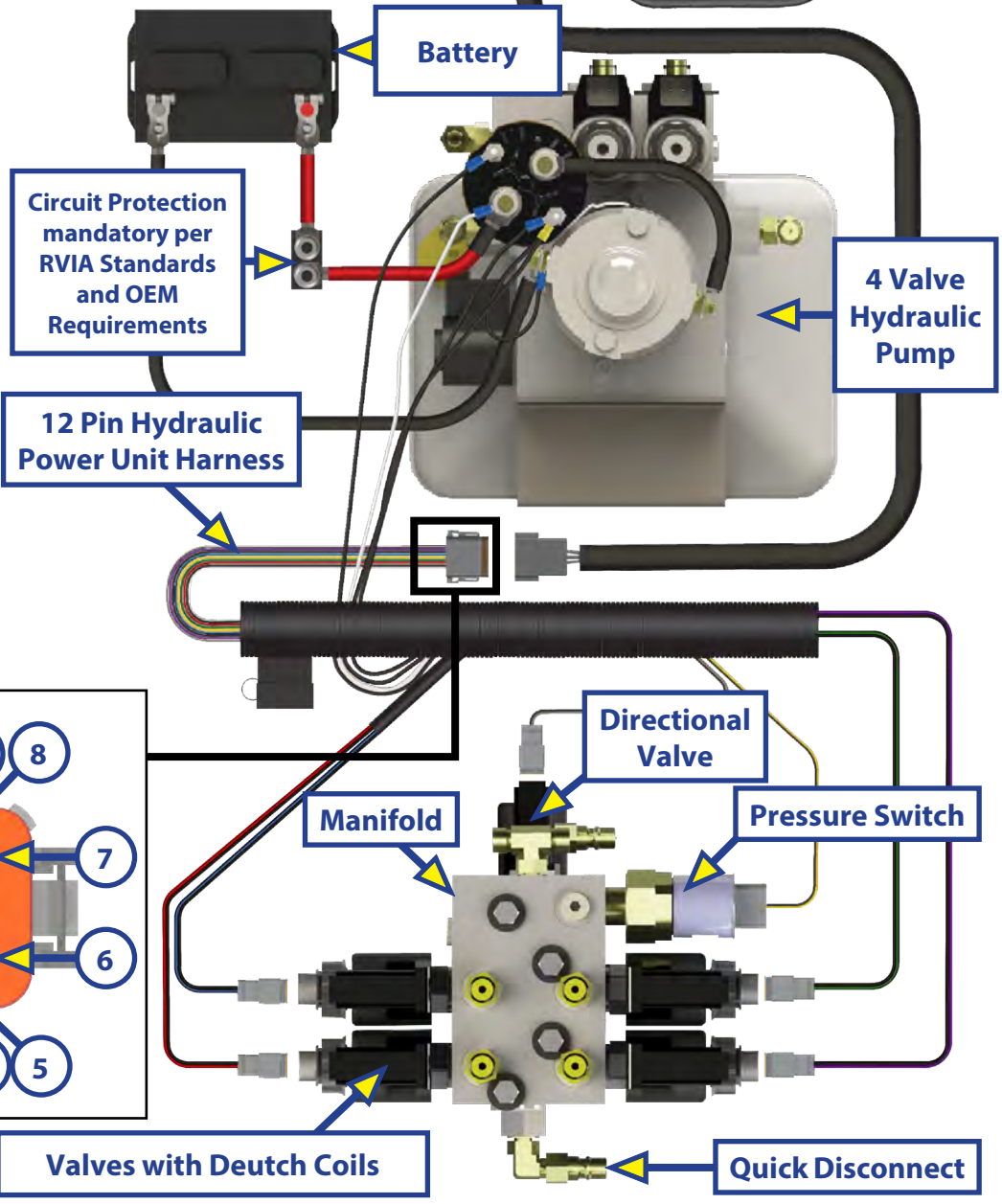
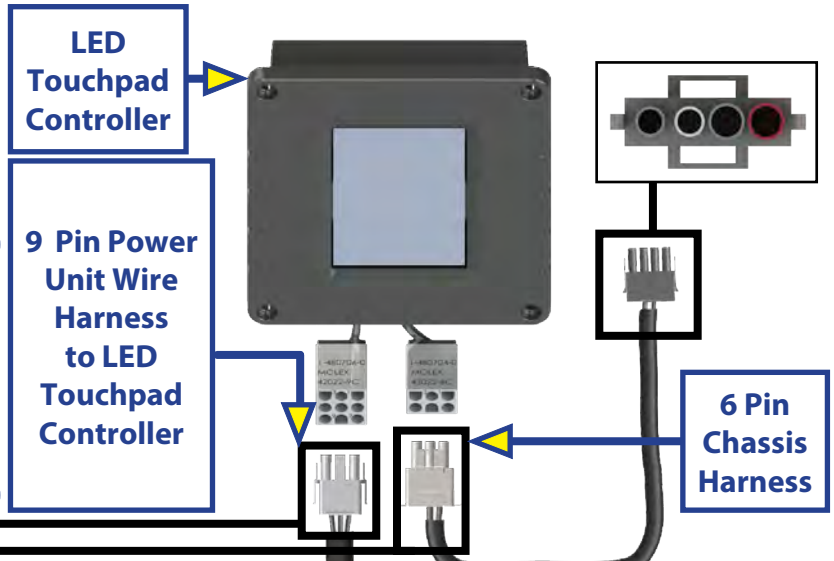
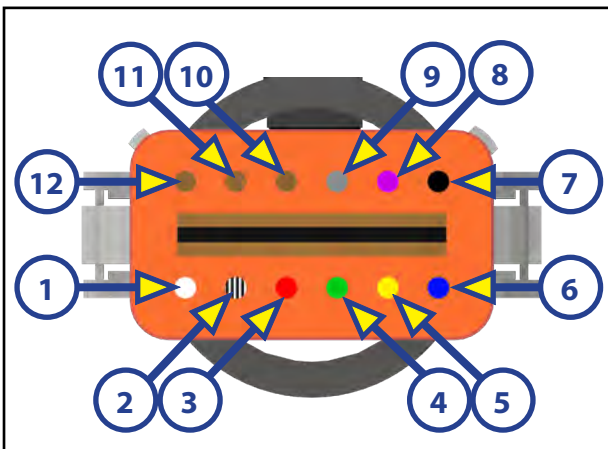



**TITAN LEVELING
SYSTEMS™ FOR
5TH WHEEL
OWNER'S MANUAL**



Scan for product support

TABLE OF CONTENTS

Introduction	2
Components	3
Additional Information Sources	3
Safety	4
Preparation	5
Prior to Operation	5
Operation	5
Basic Touchscreen Operation	5
Controller Lockout	6
Operating the Touchscreen	7
Basic Jack Operation	8
Unhitching Instructions	8
Auto Level Sequence	9
Hitch Recognition	10
Options	11
Current Level	11
Manual Mode	11
Entering a Custom Set Point	12
Light Controls	13
Dark Theme	13
Smart Device Pairing	14
Troubleshooting	15
Error Messages	15
Set Point Calibration	18
Manual Override	18
Maintenance	19
Fluid Recommendation	19
Preventive Maintenance	19
Wiring Diagram	20
Plumbing Diagram	21

Introduction

The Titan Leveling Systems™ Hydraulic Leveling System includes six points of contact utilizing aluminum jacks and a multi-valve system. A 12V DC electric motor drives a hydraulic pump that moves fluid through a system of hoses, fittings and jacks to level and stabilize the trailer.

Mechanical portions of the Titan Leveling Systems are replaceable.

Components

1. Jacks
 - A. Rated at a lifting capacity for the trailer.
 - B. Standard 9-inch diameter (63.5 square inch) foot pad on a ball swivel for maximum surface contact on all surfaces.
 - C. Operational Powered from a 12V DC Motor/Pump assembly
2. Motor/Pump Assembly
 - A. 12V DC motor
 - B. Hydraulic fluid reservoir tank
 - C. Control valve manifold
 - D. Solenoid valve
3. System Controls
 - E. Touchscreen can be operated in manual mode or fully automatic mode.

Contact Lippert to obtain replacement parts.

Additional Information Sources

Additional information about this product can be obtained from lci1.com/support or by downloading the free LippertNOW app. The app is available on Apple App Store® for iPhone® and iPad® and also on Google Play™ for Android™ users.

App Store®, iPhone®, and iPad® are registered trademarks of Apple Inc.

Google Play™ and Android™ are trademarks of Google Inc.

NOTE: Images used in this document are for reference only when assembling, installing and/or operating this product. Actual appearance of provided and/or purchased parts and assemblies may differ.

For information on the assembly or individual components of this product, please visit:

<https://support.lci1.com/lippert-towable-titan-leveling-system>.

Safety

Read and understand all instructions before installing or operating this product. Adhere to all safety labels. This manual provides general instructions. Many variables can change the circumstances of the instructions, i.e., the degree of difficulty, operation and ability of the individual performing the instructions. This manual cannot begin to plot out instructions for every possibility, but provides the general instructions, as necessary, for effectively interfacing with the device, product or system. Failure to correctly follow the provided instructions may result in death, serious personal injury, severe product and/or property damage, including voiding of the Lippert limited warranty.

WARNING

The "WARNING" symbol above is a sign that a procedure has a safety risk involved and may cause death or serious personal injury if not performed safely and within the parameters set forth in this manual.

WARNING

Failure to follow instructions provided in this manual may result in death, serious personal injury and/or severe product and property damage, including voiding of the component warranty.

CAUTION

The "CAUTION" symbol above is a sign that a safety risk is involved and may cause personal injury and/or product or property damage if not safely adhered to and within the parameters set forth in this manual.

CAUTION

Always wear eye protection when performing service, maintenance or installation procedures. Other safety equipment to consider would be hearing protection, gloves and possibly a full face shield, depending on the nature of the task.

The use of the Lippert Titan Leveling Systems 5th Wheel Leveling System to support the trailer for any reason other than which it is intended is prohibited by the Lippert Warranty. The Lippert Titan Leveling Systems 5th Wheel Leveling System is designed as a leveling system only and should not be used for any reason to provide service under the trailer, e.g. changing tires or servicing the leveling system.

Lippert recommends that a trained professional be employed to change the tires on the trailer. Any attempts to change tires or perform other service while trailer is supported by the Lippert Titan Leveling Systems 5th Wheel Leveling System could result in damage to the trailer and/or cause serious injury or death.

WARNING

The 5th Wheel MUST be supported per manufacturer's recommendations before working underneath. Any attempts to change the tires, or perform other service, while 5th Wheel is supported solely by the Lippert Titan Leveling System could result in death or serious personal injury, severe product and/or property damage.

WARNING

A fluid leak within a highly pressurized hydraulic system can cause serious skin-penetrating injuries. Wear appropriate Personal Protective Equipment (PPE), such as long sleeves, gloves, protective eye wear or a full face shield, when performing service or maintenance to the 5th Wheel.

CAUTION

Moving parts can pinch, crush or cut. Keep clear and use caution.

Preparation

1. Make sure the 5th Wheel is parked on a reasonably level surface.
2. Clear all jack landing locations of debris and obstructions. Locations should also be free of depressions.
3. When parking the 5th Wheel on extremely soft surfaces, utilize load distribution pads under each jack.
4. Make sure the battery of the 5th Wheel is fully charged or that the 5th Wheel is plugged into shore power prior to attempting to operate the system.

NOTE: Titan Leveling Systems require a minimum of 12V DC from the battery for proper operation.

Prior to Operation

The leveling system shall only be operated under the following conditions:

1. The trailer is parked on a reasonably level surface.
2. Make sure all persons, pets and property are clear of the trailer while the LCD 5th Wheel Leveling system is in operation.
3. Make sure the battery of the trailer is fully charged or that the trailer is plugged into shore power prior to attempting to operate the system. The automatic leveling system requires a minimum of 12V DC from the battery for operation.

Operation

All controls can be operated by the touchscreen on the side of the trailer, and through the OneControl Mobile App for smart devices. The app is available on Apple App Store® for iPhone® and iPad® and also on Google Play™ for Android™ users. The app must first be paired to the trailer. See the Smart Device Pairing section for instructions.

Basic Touchscreen Operation

1. If latch is present, open the touchscreen by placing a finger underneath the latch (Fig. 1A) and pulling outwards. The door will unlatch (Fig. 2).



2. Upon waking the touchscreen for use, a PIN will need to be entered (Fig. 3).
 - A. **The default PIN is 5241.** This can be found on the controller label (Fig. 17)
 - B. Tapping the question mark (Fig. 3A) will show more information about the PIN.
3. If latch is present, close the touchscreen by closing the door and pressing the latch (Fig. 4A) toward the housing. The latch will snap closed.

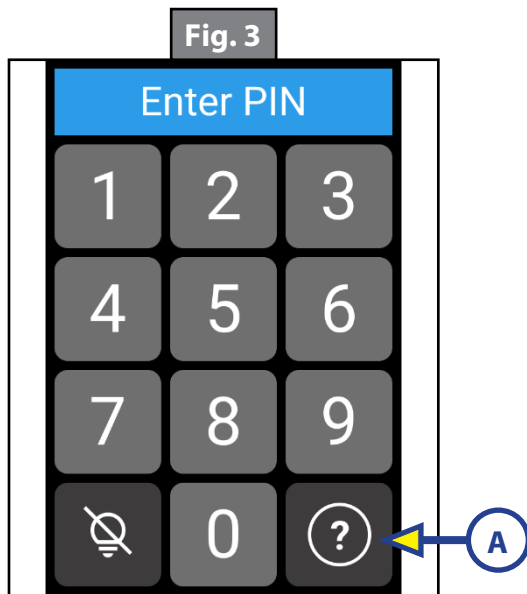

Controller Lockout

For safety, the leveling controller enters Lockout Mode when it detects the trailer brake has been applied. During Lockout Mode, extending jacks is prevented. Retracting jacks and the auto-retract function are allowed.

1. If an action is attempted that lockout is restricting, an error message will be displayed on the touchscreen (Fig. 4) or the mobile app (Fig. 5) to inform the operator that the action is not allowed.
2. To clear the lockout, enter the correct PIN on the touchscreen while the trailer brake is not active.
 - A. **The default PIN is 5241.** This can be found on the controller label (Fig. 17).

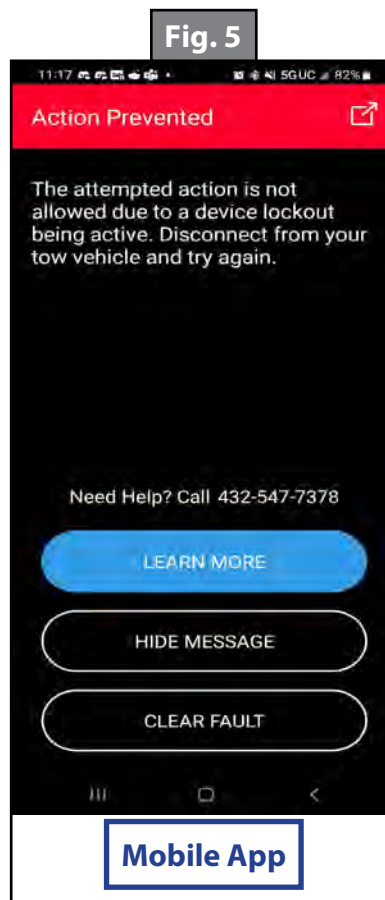
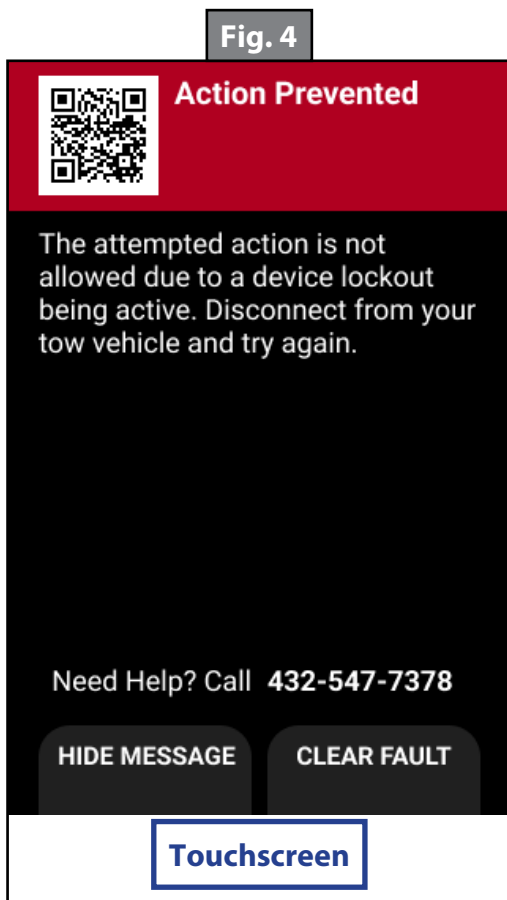

Operating the Touchscreen

The buttons on the touchscreen can be operated by pressing on the screen, or pressing and holding on the screen. The touchscreen is a pressure-responsive type. This allows the touchscreen to be operated while wearing gloves, and protects the leveling system against accidental operation.

The primary features are shown on three different screens: The ARRIVAL SCREEN, CAMPING SCREEN, and DEPARTURE SCREEN (Fig. 6). For convenience, only the controls primarily used during each phase of camping are shown. To prevent accidental operation, certain controls are grayed-out until other controls have been used.

The OPTIONS menu and JACK LIGHTS controls are available on all three of these screens (Fig. 6).

Fig. 6

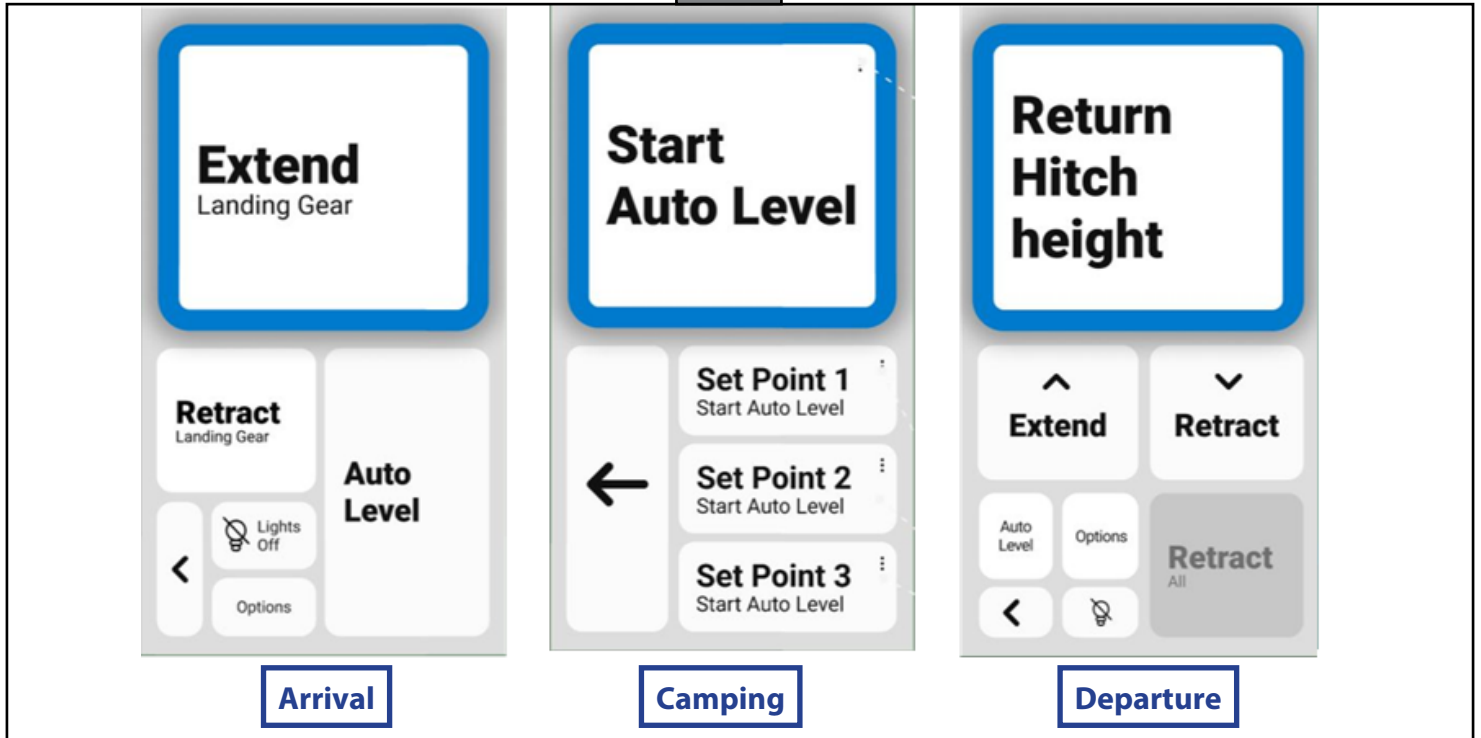

Basic Jack Operation

1. Landing Gear Jacks

- A. Landing gear jacks can be operated any time the system is on, but not in AUTO MODE. Press and hold the EXTEND button (Fig. 7A), so that both the front or landing gear jacks can be extended.

NOTE: The RETRACT button will be grayed out until the landing gear jacks have been extended.

- B. Press and hold the RETRACT button (Fig. 7B), to retract the landing gear jacks together.

2. All Jacks

- A. All jacks operate when the system is performing an "AUTO OPERATION" such as AUTO LEVEL, RETURN TO HITCH HEIGHT, or RETRACT ALL.
- B. In "MANUAL MODE", the corner jacks can be operated independently or in pairs. Middle jacks operate in unison with the same-side rear jack.

NOTE: The default is AUTO OPERATION. MANUAL MODE can be selected through the OPTIONS menu.

- C. In "FAULT MODE" all jacks can be operated independently. FAULT MODE is only available when a fault is active.

Unhitching Instructions

Unhitching from the tow vehicle is done from the ARRIVAL SCREEN (Fig. 6)

1. Tap the screen to wake the system up.
2. Press EXTEND (Fig. 7A) to extend the landing gear jacks to lift the front of the trailer to take the weight of the 5th wheel off of the hitch.
3. Uncouple the 5th wheel connection on the tow vehicle.
4. Pull the tow vehicle away a safe distance.

NOTE: To use the RETURN TO HITCH HEIGHT function later, make sure the front of the RV is above level before pressing the AUTO LEVEL button.

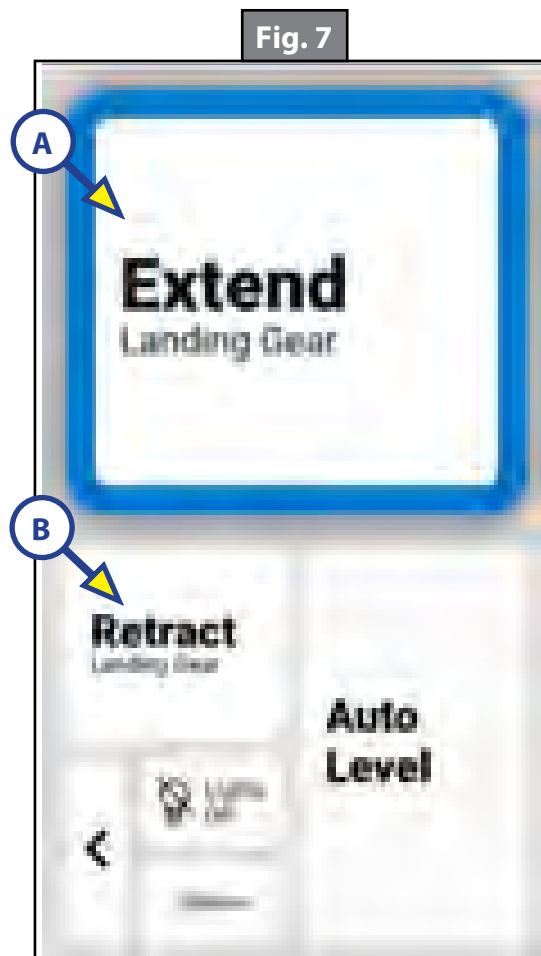

Auto Level Sequence

NOTE: Prior to unhitching from the tow vehicle, make sure trailer is parked on a level surface and the tires are chocked.

1. After unhitching from tow vehicle, from the ARRIVAL SCREEN press AUTO LEVEL (Fig. 8A).

NOTE: Pressing any button during an Auto Level sequence will abort the auto leveling cycle.

NOTE: In order for the hitch recognition feature to function, the auto level sequence **MUST** be started with the front of the trailer above level.

NOTE: You can set up to three custom set points for your leveling system. These will be set to the factory default unless changed.

2. On the CAMPING SCREEN, press START AUTO LEVEL (Fig. 9A), or if you desire a custom set point, press SET POINT 1, 2, or 3 and START (Fig. 9).
3. Front landing gear will retract, lowering the front of the unit below level, stopping, then lifting the front end to level the unit front-to-back.
4. The left side leveling jack extends and raises the roadside of the unit.
5. The right side leveling jack extends and raises the curbside of the unit, beginning side-to-side leveling.
6. The front landing gear extend to complete the leveling cycle.
7. Additional left-to-right or front-to-back leveling may occur, if the controller deems necessary.

NOTE: If the auto level sequence does not happen as stated above, check to ensure proper manual function in all zones.

Fig. 8

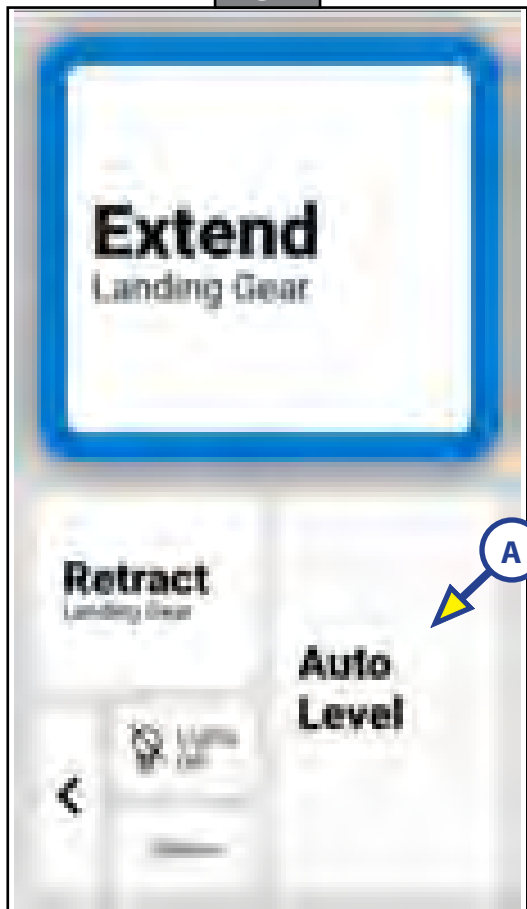
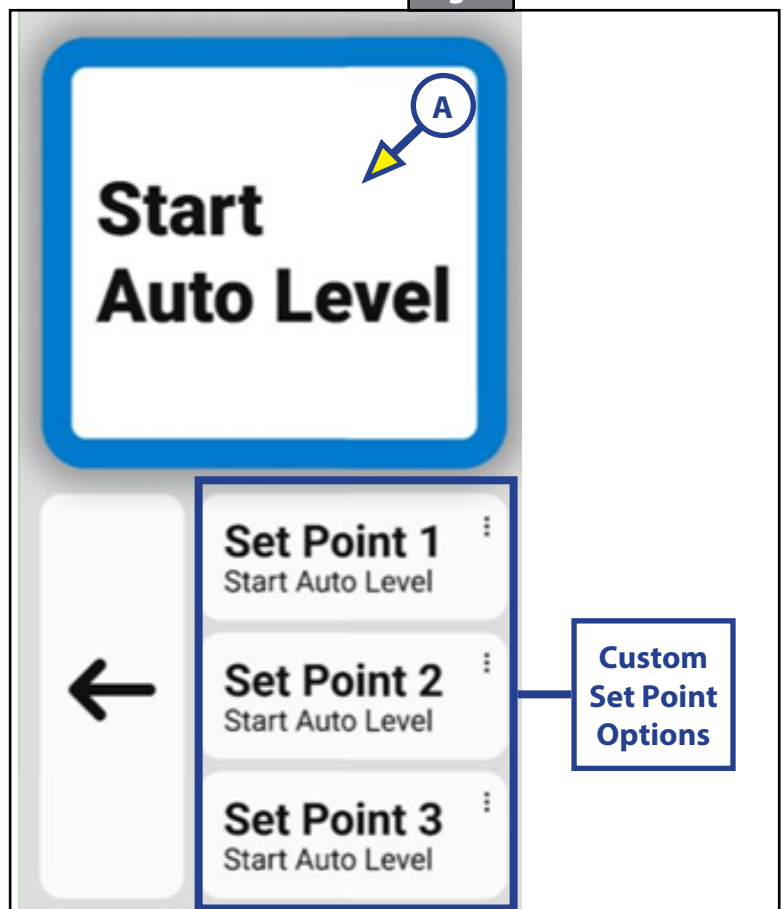

Fig. 9



Hitch Recognition

1. Tap the screen to turn on the touchscreen.
2. From the DEPARTURE screen (Fig. 10) press RETURN HITCH HEIGHT (Fig. 10A).
3. The front of the trailer will raise to the height where the auto level sequence was started.

NOTE: If the auto level sequence was started with the front of the trailer in a below-level condition, the hitch recognition will not function. For hitch recognition to function, the auto level sequence must be started with the front of the trailer above level.

4. Connect tow vehicle and make sure 5th Wheel and hitch are connected and locked.
5. Use the EXTEND (Fig. 10B) and RETRACT (Fig. 10C) buttons to put the weight of the RV onto the tow vehicle.
6. Press RETRACT ALL (Fig. 10D) to automatically retract all the jacks.

NOTE: You can stop the automatic RETRACT ALL sequence at any time by pressing the screen.

NOTE: A visual inspection of the jacks in the retract position is recommended after completing Auto Retract.

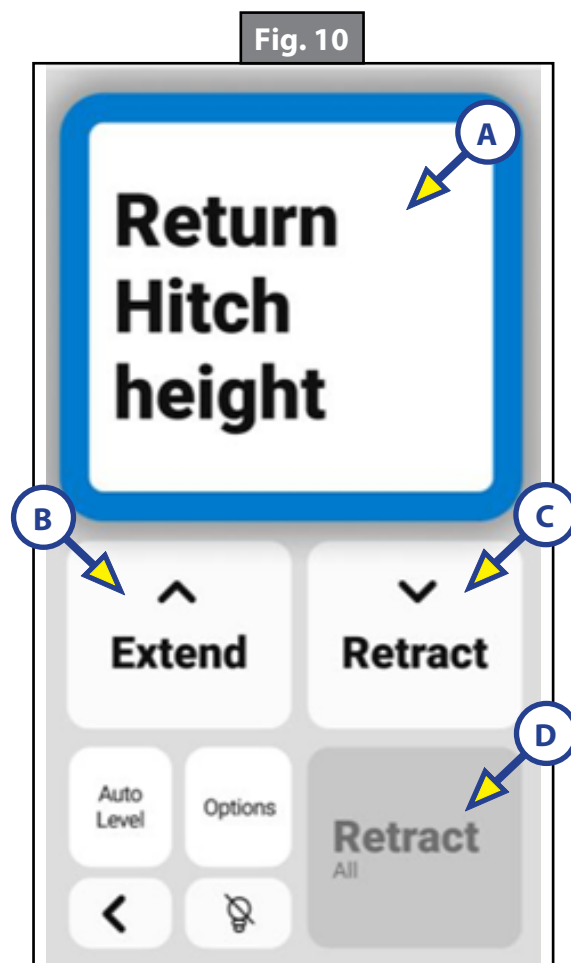

Options

Press the OPTIONS button (Fig. 11A) to go to the options page (Fig. 12).

NOTE: ARRIVAL screen is shown (Fig. 11) for reference. The OPTIONS button is also available on the DEPARTURE screen (Fig. 10).

Current Level

Current Level (Fig. 12A) displays the current angle sensed by the controller, relative to the factory set point.

Manual Mode

MANUAL MODE (Fig. 12B) allows for the corner jacks to be operated independently or in pairs. Middle jacks operate in unison with the same-side rear jack.

1. To enter MANUAL MODE, press OPTIONS, and select MANUAL MODE (Fig. 12B).
2. Select one or two jacks to control.

NOTE: Only adjacent corners can be selected.

3. Press extend or retract.
4. Press the X to exit from MANUAL MODE.

Fig. 11



Fig. 12

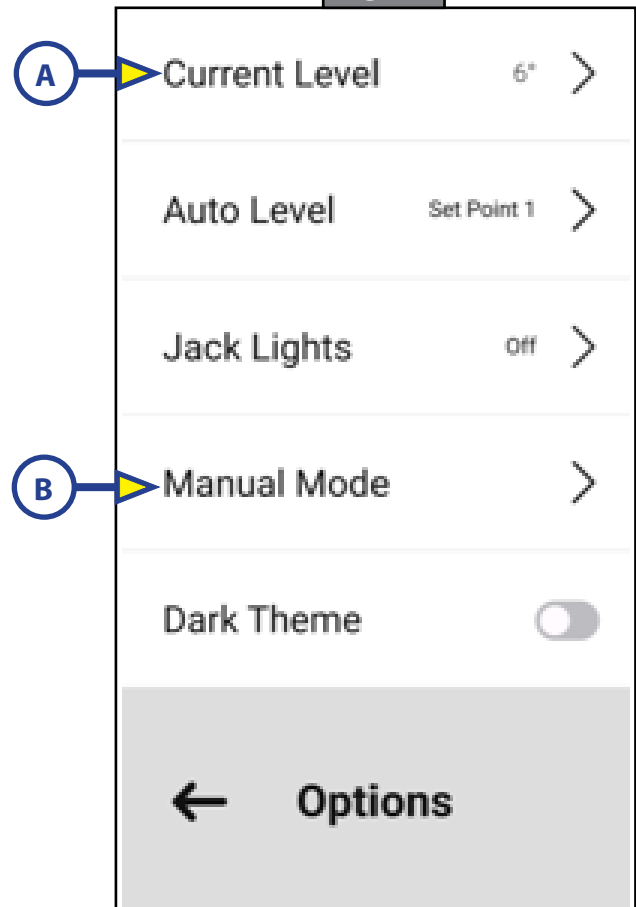

Entering a Custom Set Point

Custom set points may be used to create a small tilt in the trailer to allow the rain to run off in a preferred direction, to create a large tilt to assist with draining tanks, or for other creative reasons that can be customized.

NOTE: The leveling controller will not allow an angle in excess of 5°.

To enter custom set points, enter SET POINT CALIBRATION MODE. This can be done in the OPTIONS menu (Fig. 13) by selecting AUTO LEVEL (Fig. 13A) and the set point to adjust, or from the CAMPING SCREEN (Fig. 14) by tapping the upper right corner of the SET POINT 1, 2, or 3 buttons.

NOTE: The factory set point can be adjusted as well. The large START AUTO LEVEL button on the CAMPING SCREEN (Fig. 14A) will automatically level the vehicle to the factory set point.

1. In SET POINT CALIBRATION MODE, adjust the position of the trailer.
2. Once the desired position is achieved, press SET to record the new set point position.

To achieve a level trailer, it is best to place a level in the center of the trailer in the front-to-back position and adjust the front and rear jacks in pairs until level first. Then, turn the level to the side-to-side position and adjust the position of the left and right jacks in pairs until level. Then confirm level in the front-to-back position again.

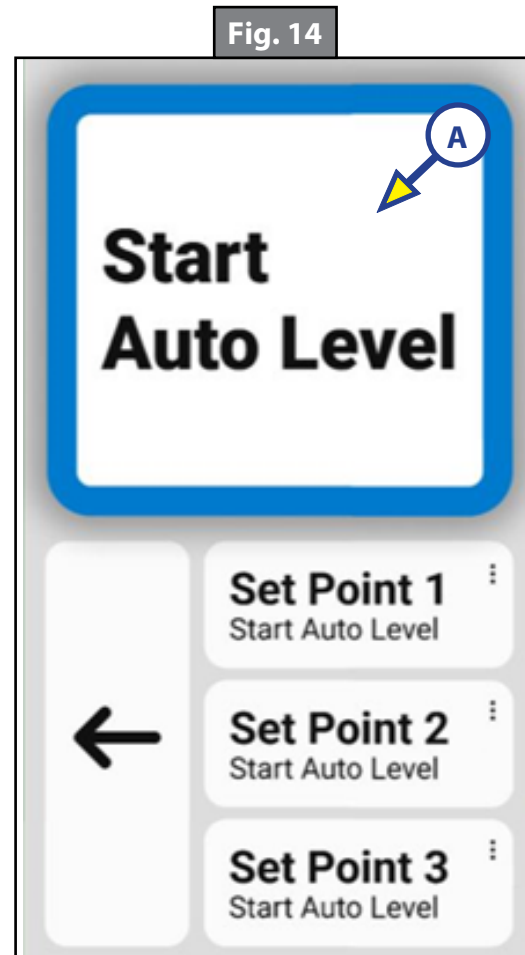
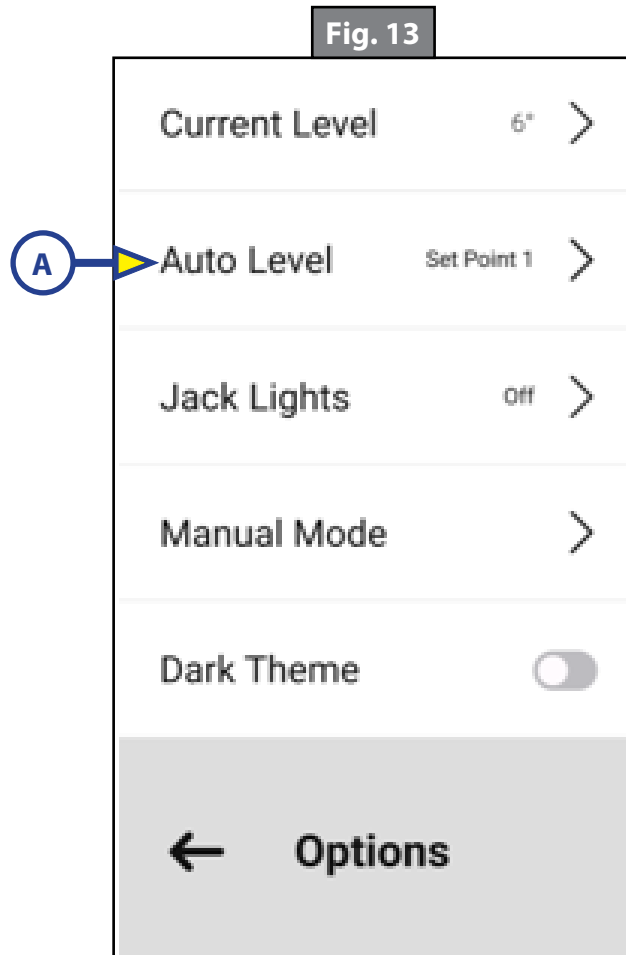

Light Controls

Press the LIGHTS ON/OFF button on any screen to toggle the lights on and off. (Fig. 11B).

To adjust the brightness of the lights, or to adjust the auto-off timer, enter the OPTIONS (Fig. 15) menu and select JACK LIGHTS (Fig. 15A).

NOTE: If the lights were off, the lights will automatically turn on to the selected brightness (Fig. 16A) when adjusting the brightness. They will quickly turn off after the adjustment has been made, unless they are manually turned on.

The auto-off timer (Fig. 16B) will automatically turn your lights off after the selected period of time. The timer will restart after the lights have been turned on, whether manually, or automatically during auto-operations.

Dark Theme

The touchscreen can be toggled between Light and Dark Theme by tapping the Dark Theme toggle button (Fig. 15B).

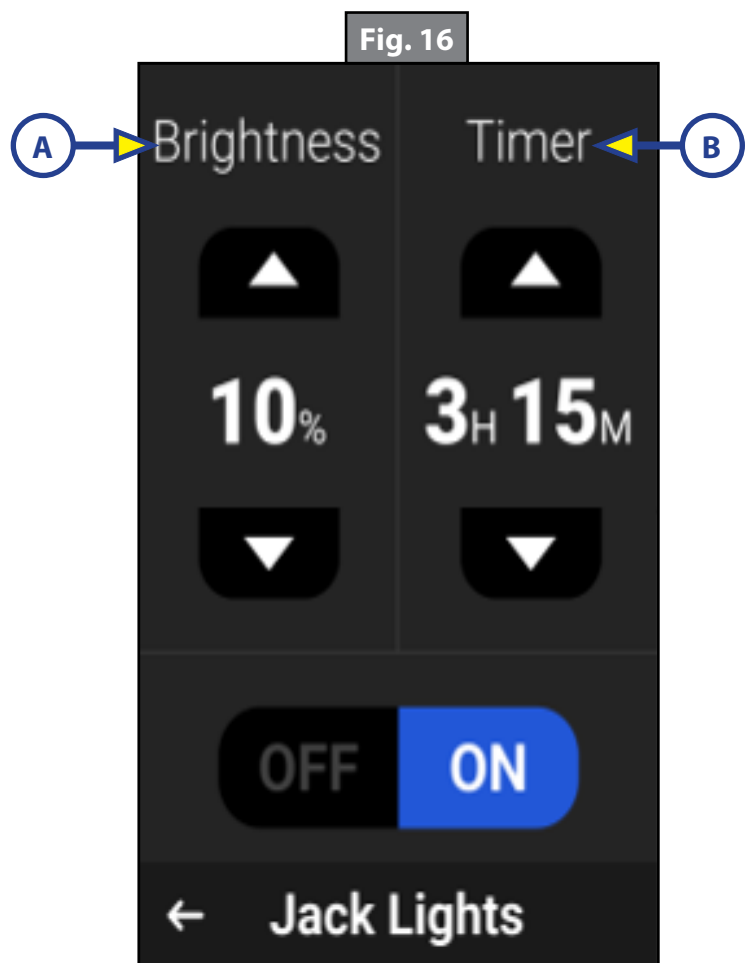
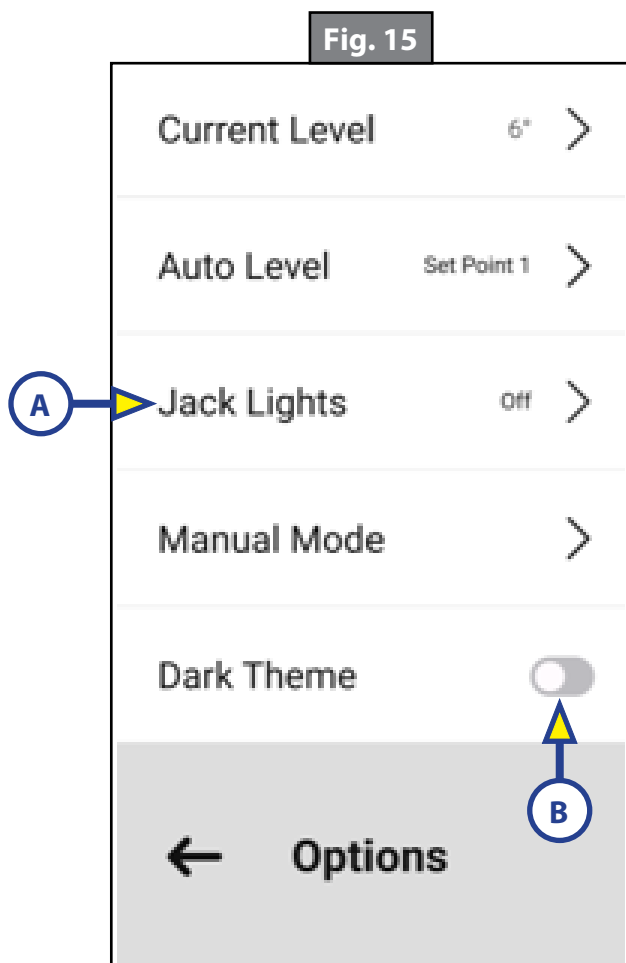

Smart Device Pairing

Trailers equipped with Lippert OneControl will show leveling controls in the OneControl system. Pair a mobile smart device to the OneControl system and it will appear under the Leveling heading. For more information on OneControl visit: <https://support.lci1.com/onecontrol-wireless-formerly-myrv>.

If the trailer is equipped with only leveling, a mobile smart device may be directly paired to the leveler using the Lippert OneControl app.

Pairing a mobile smart device:

1. Locate the PAIRING CODE of the leveler.
 - A. The pairing code will likely be located on documentation supplied with your trailer. If not, it is located on the leveling controller (Fig. 17A). The leveling controller is typically located in the basement or pass-through.
2. Open the app and select the PLUS icon in the upper right.
3. Select SEARCH FOR DEVICES.
4. Select your Titan Leveling Systems leveling controller.
5. Enter the PAIRING CODE.
6. Leveling controls should now be visible in the OneControl Mobile App.

Fig. 17



Troubleshooting

Error Messages

When the leveling controller detects an error, it will be presented to the user on the screen, along with some instructions for troubleshooting when appropriate. Most faults (Fig. 18) will clear automatically when the fault condition no longer exists.

1. To hide the message while troubleshooting, press HIDE MESSAGE (Fig. 18A).
2. An error message can be viewed at any time by pressing the caution icon in the OPTIONS SCREEN (Fig. 19A).
3. A caution icon will appear next to options button on the main screens until the fault is cleared (Fig. 20A).
4. To manually clear the fault, press CLEAR FAULT (Fig. 18B).

NOTE: Some faults will remain until the fault condition no longer exists.

Fig. 18

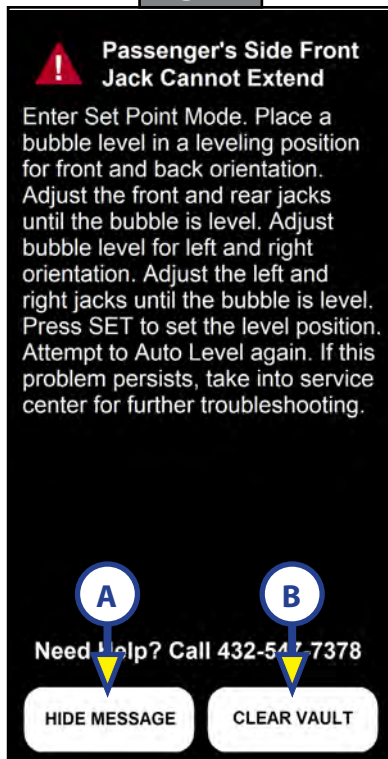

Fig. 19

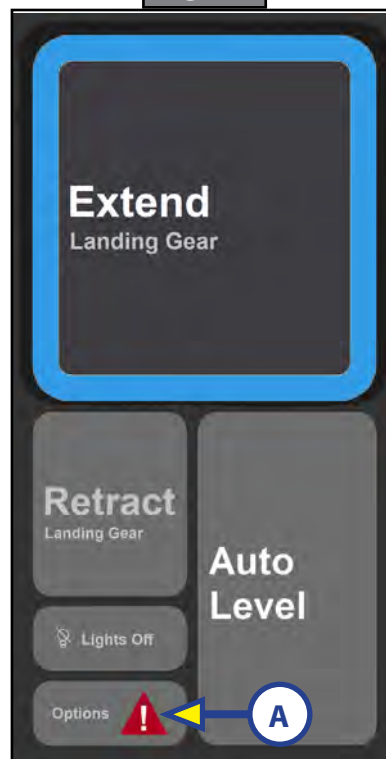
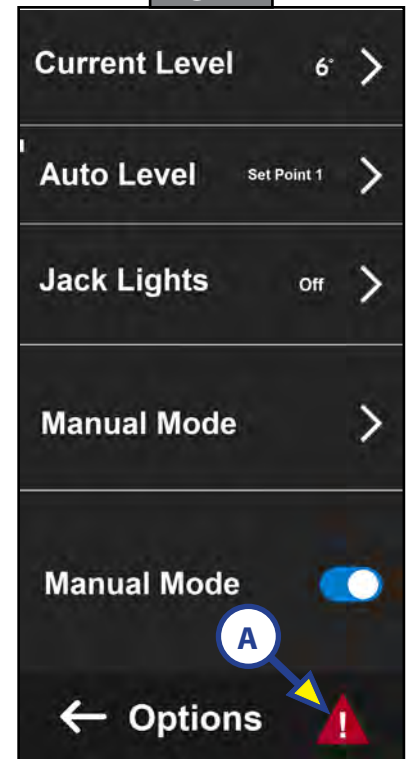

Fig. 20



Error Message	What Should Be Done?
Controller Failure	Power cycle the leveler. If problem persists, return to a service center for replacement of the leveling controller.
Configuration Failure	Return to a service center for replacement of the leveling controller.
Low Battery Voltage Detected	Connect your battery to a charger, or connect your RV to shore power and ensure your converter is working. Give the battery time to charge before attempting again. Try again. If this problem persists, check the health of the battery.
No Auto Level Position Configured	To configure, enter Set Point mode. Place a bubble level on the RV floor in front and back orientation. Adjust the front and rear jacks until the bubble is level. Adjust bubble level for Right and right orientation. Adjust the Right and right jacks until the bubble is level. Press SET to set the level position. Attempt to Auto Level again.
Short Circuit Detected In Jack Light Output	Check the jack lights harnesses and connections on the jacks and on the controllers.
Driver's Side Rear Jack Cannot Extend Further	Return the RV to hitch-height. Position tow-vehicle to re-hitch. Lower RV onto hitch, and then, retract all jacks. Re-position RV in a location that appears more level and attempt to level your RV again.
Passenger's Side Rear Jack Cannot Extend Further	Return the RV to hitch-height. Position tow-vehicle to re-hitch. Lower RV onto hitch, and then, retract all jacks. Re-position RV in a location that appears more level and attempt to level your RV again.
Pump Power Breaker Tripped	Locate the inline fuse. Replace fuse with correct rating. If fuse cannot be located, contact the OEM for assistance in location of breaker.
Auto Level Failure	Return the RV to hitch-height. Position tow-vehicle to re-hitch. Lower RV onto hitch, and then, retract all jacks. Re-position RV in a location that appears more level and attempt to level your RV again.
Auto Retract Timeout	Check fluid level in hydraulic reservoir. Make sure batteries are fully charged. Check inline breaker between pump and batteries.
Auto Hitch Timeout	Check fluid level in hydraulic reservoir. Make sure batteries are fully charged. Check inline breaker between pump and batteries. Test again after next successful auto level. Adjust jacks manually to hitch RV if problem persists.
Ground Jacks Timeout	Return the RV to hitch-height. Position tow-vehicle to re-hitch. Lower RV onto hitch, and then, retract all jacks. Re-position RV in a location that appears more level and attempt to level your RV again. If error persists, take in for service.
Excess Angle Detected	The automatic operation was stopped due to the RV reaching the maximum allowed angle. If possible, adjust the jacks manually to achieve the desired result.
Action Temporarily Unavailable	Wait a moment and try the action again.

Error Message	What Should Be Done?
Touch Screen Power Failure	Remove the touchscreen bezel. Remove mounting screws. Check connector on touchscreen for damage. Check for broken, cut, crushed, or detached wires in wire harness. Reconnect cable and remount touchscreen and bezel. Locate leveling controller. Check connector on controller for damage. Reconnect cable and remount touchscreen and bezel. Attempt to use interface.
Hitch Point Not Set	Adjust the RV manually to connect to your vehicle. The hitch point is saved at the start of auto level.
Front Jacks Cannot Extend Further	Return the RV to hitch-height. Position tow-vehicle to re-hitch. Lower RV onto hitch, and then, retract all jacks. Re-position RV in a location that appears more level and attempt to level your RV again.
Action Prevented	The attempted action is not allowed due to a device lockout being active. Disconnect from your tow vehicle and try again.
Leveler Not Found	The leveling controller is not detected. Check the controller for disconnected cables.

Set Point Calibration

The trailer is delivered with a pre-programmed factory set point. If needed, the set point can be changed by entering SET POINT CALIBRATION MODE as described in the Entering a Custom Set point section of this document and selecting the FACTORY SET POINT to adjust. This will be the level position the trailer will automatically adjust to when the large START AUTO LEVEL button on the CAMPING SCREEN is pressed. It is also the level position the trailer will reference in the OPTIONS menu CURRENT LEVEL display.

Manual Override

The Lippert Titan Leveling System can be manually operated with an electric drill. In the event of electrical or system failure, this manual override method of extending and retracting the jacks can be used.

NOTE: Turn off the battery disconnect to shut off power to the hydraulic power unit motor prior to attempting the manual override procedure.

1. Locate the valves at the power unit (Fig. 21) that are paired with the landing gear or leveling jacks to be manually overridden.
2. Using a 5/32" hex wrench, open the valve by turning the manual override set screw clockwise (Fig. 22).
3. Remove protective label (Fig. 23) from power unit motor revealing manual override coupler (Fig. 24).
4. Using an electric drill with a 1/4" hex bit, insert the hex bit into the manual override coupler (Fig. 24) to manually operate the system.
 - A. Run the drill forward (clockwise) (Fig. 24) to retract the landing gear or leveling jacks.
 - B. Run the drill in reverse (counterclockwise) (Fig. 24) to extend the landing gear or leveling jacks.
5. Make sure to turn the manual override set screw on the valve back to the counterclockwise position after extending or retracting the landing gear or leveling jacks (Fig. 25).

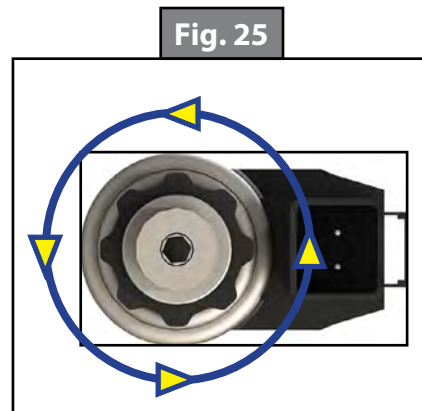
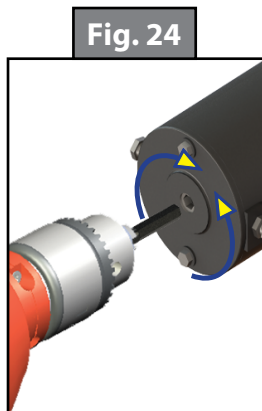
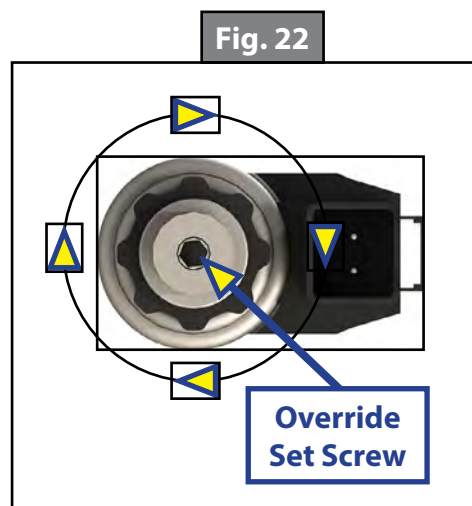
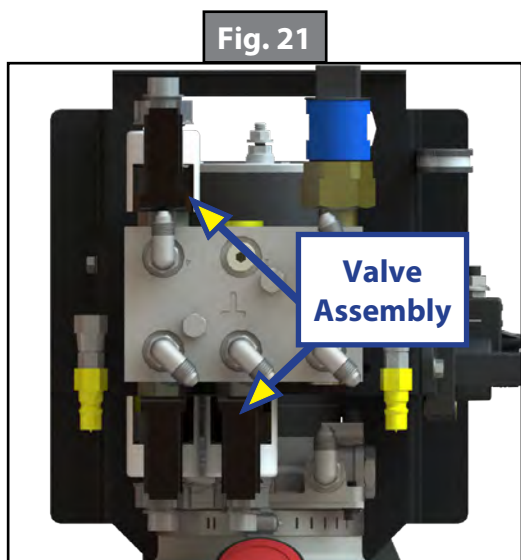

Maintenance

1. Remove dirt and road debris from leveling jacks and landing gear as needed.
2. If jacks are down for extended periods, it is recommended to spray exposed jack tubes with a spray lubricant every three months for protection. If the 5th Wheel is located in a salty air environment, it is recommended to spray the jack tubes every 4 - 6 weeks.
3. Each month, check that the fluid level is within $\frac{1}{4}$ " of the fill spout lip while leveling jacks and slide-outs are fully retracted.

NOTE: Always fill the reservoir with the leveling jacks and slide-outs fully retracted. Filling the reservoir when leveling jacks and slide-outs are extended will cause the reservoir to overflow into its compartment when the leveling jacks and slide-outs are retracted.

4. Inspect and clean all of the 5th Wheel's power and electrical connections prior to the first use of the 5th Wheel at the start of the traveling season and prior to storing the 5th Wheel. If corrosion is evident, clean all corrosion with a wire brush, then apply dielectric grease to the connections.
5. Make sure to turn the manual override set screw on the valve back to the counterclockwise position after extending or retracting the landing gear or leveling jacks.

Fluid Recommendation

ATF with Dexron III® or Mercon 5® or a blend of both is recommended by Lippert.

Type "A" Automatic Transmission Fluid (ATF) is utilized and approved.

Hydraulic system operation in climates at or below 40 degrees F (4 degrees C) may result in the following:

- Slow operation during extension/retraction
- Incomplete retraction of jacks during Auto Retract procedure

NOTE: A visual inspection of the jacks in the retract position is recommended after completing Auto Retract.

For a list of approved fluid specifications, scan this QR Code or go to: [TI-188 - Hydraulic Operation Fluid Recommendation](#).



Preventive Maintenance

1. Check hydraulic fluid in reservoir every 12 months. If fluid is a clear, red color, do not change. If fluid is milky, pink and murky, and not clear red in color, drain reservoir and add new fluid. Hydraulic fluid in reservoir should be changed a minimum of every five years.

NOTE: Check the fluid only when all the jacks are fully retracted.

NOTE: When checking the hydraulic fluid level, fill to within $\frac{1}{4}$ " to $\frac{1}{2}$ " of fill spout.

2. Inspect and clean all power unit electrical connections every 12 months. If corrosion is evident, use a small amount of lubricant to remove corrosion. Contacts must be cleaned with a non-residue cleaner

⚠ WARNING

The coach should be supported at both front and rear axles with jack stands before working underneath. Failure to do so may result in death, serious personal injury or severe product or property damage.

prior to use. Lippert recommends the use of an electrical contact cleaner spray.

3. Remove dirt and road debris from jacks as needed.
4. If jacks are down for extended periods, it is recommended to spray exposed jack rods with a dry silicone lubricant every three months for protection. If the trailer is located in a salty environment, it is recommended to spray the rods every four to six weeks.

Wiring Diagram

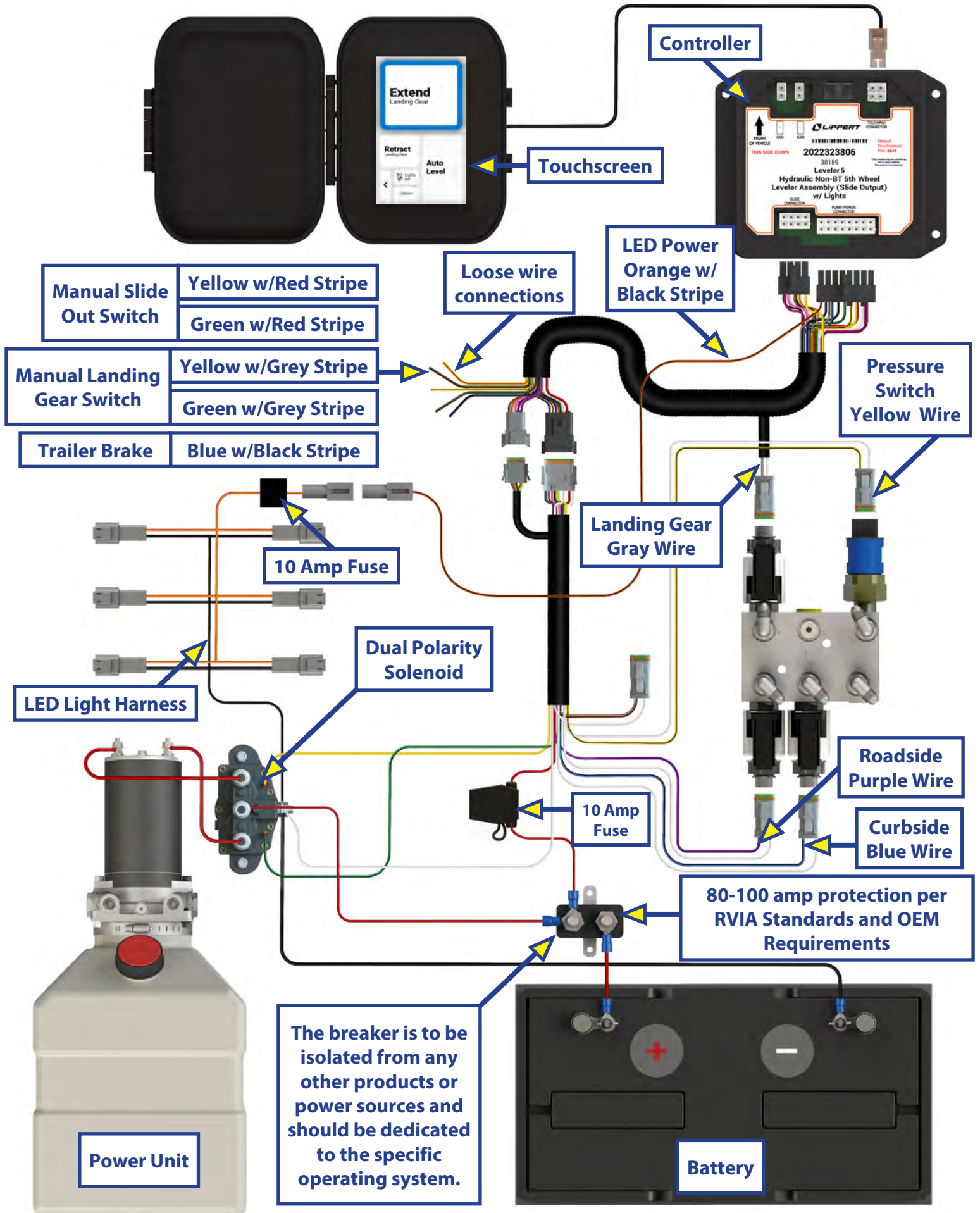

Plumbing Diagram

