

TOWING

Follow These Steps to Determine the Pin Box Replacement Model:

1. Look for the white sticker with a 4-digit number on it (ex. 1621 or 1716).
2. What is the gross vehicle weight rating (GVWR) of the unit?
3. Visually compare illustration to the mounting wing on the 5th wheel.
4. Measure length of box (front row of bolts to center of kingpin E).
5. Measure bolt pattern (all three dimensions A, B and C if needed).
6. Measure box width (G).

NOTE: Write in the measurements of the Pin Box in the Actual Dimensions area of the chart.

Two-Row Hole Pattern

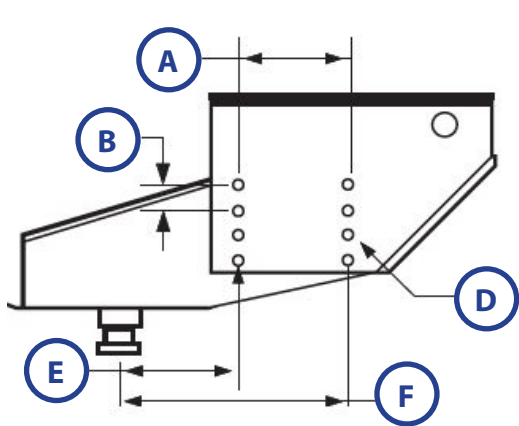

Three-Row Hole Pattern

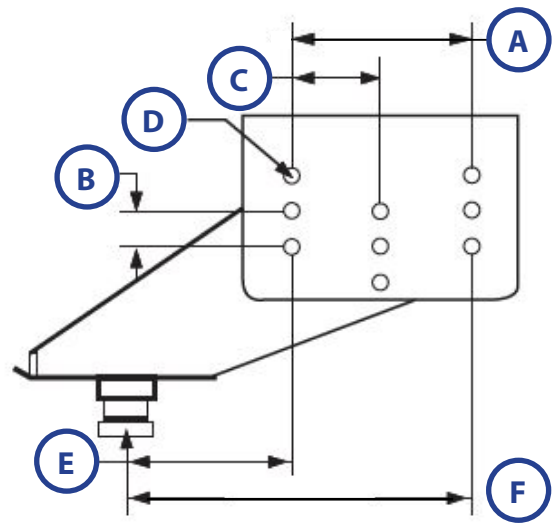

OEM Part No.	LCI Model	Bolt Pattern	Style	Horizontal Distance Between Bolt Pattern	Vertical Distance Between Bolt Pattern	Distance Between Rows	Bolt Size	Bolt Head Size	Front Row Bolts to Kingpin Center	Rear Row Bolts to Kingpin Center	Box Width
				A	B	C	D		E	F	G
1621	L05	2-row	Long	7-7/8"	2"	N/A	5/8"	15/16"	17-3/4"	25-5/8"	12"
0719	M15	2-row	Medium	7-7/8"	2"	N/A	5/8"	15/16"	9"	16-7/8"	12"
1716	L07	3-row	Long	8-3/4"	2-1/2"	4-3/8"	5/8"	15/16"	20-3/8"	29-1/8"	12-1/2"
1116	M19	3-row	Medium	8-3/4"	2-1/2"	4-3/8"	5/8"	15/16"	14-5/8"	23-1/4"	12-1/2"

Actual Dimensions

--	--	--	--	--	--	--	--	--	--	--	--

As a supplier of components to the RV industry, safety, education and customer satisfaction are our primary concerns. Should you have any questions, please do not hesitate to contact us at (574) 537-8900 or by email at customerservice@lci1.com. Self-help tips, technical documents, product videos and a training class schedule are available at lci1.com or by downloading the MyLCI app.