

AWNINGS

Purpose

This document outlines the removal and replacement of awning fabric.

Resources Required

- 1 to 3 People
- Cordless or Electric Drill or Screw Gun
- Appropriate Drive Bits
- Zip Ties
- Two Cotter Pins (manual awning only)
- Non-Permanent Marker

Safety

⚠ CAUTION

Moving parts can pinch, crush or cut. Keep clear and use caution.

NOTE: Previous awning versions had two (2) polycords and fabric stitching along the hem. The current awning model has one (1) polycord (see Fig. 1) and no fabric stitching. This should not be mistaken as defective.

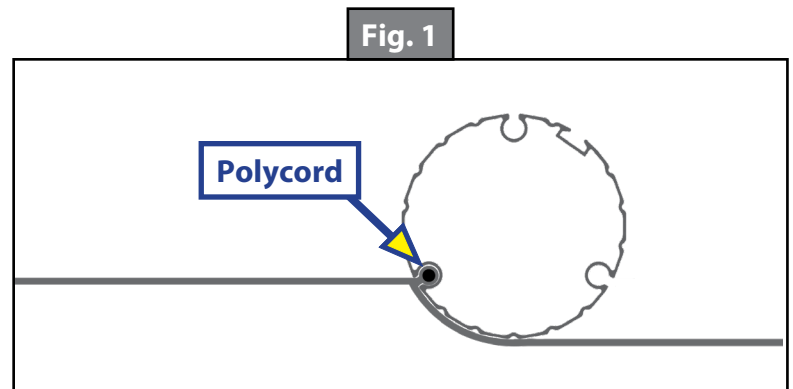

Manual Awning Fabric Replacement

Removal

1. Remove the drip cap (if equipped) from the end of the awning rail from which the fabric will be removed.
2. Extend the awning out approximately 12" and insert cotter pins through both end caps into the shafts on the head assemblies (Fig. 2).

NOTE: If the awning is 6' in length it will only need one cotter pin for the drive side end cap.

3. Secure both support arm assemblies by running a zip tie around the outer arm and around the pin on the top of the mount arm where the mount arm and inner arm connect (Fig. 3).

⚠ WARNING

If not properly secured, the support arms can kick out due to pressure from the gas strut, which may result in serious injury or property damage.

AWNINGS

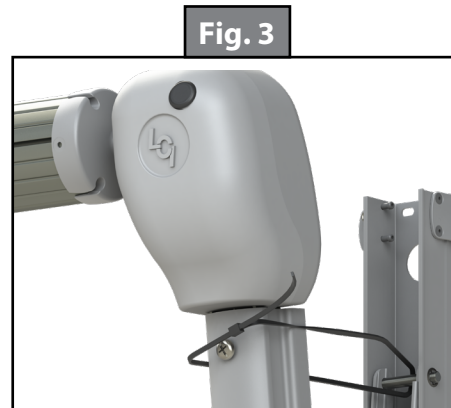
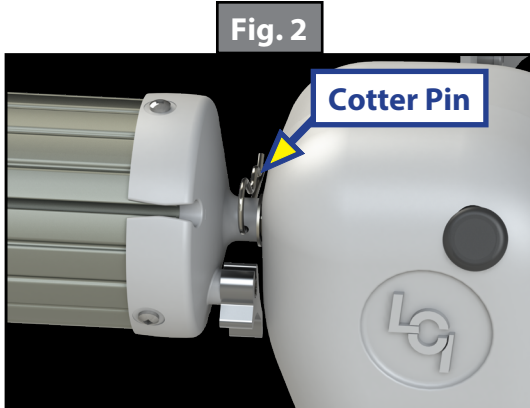

4. Remove the screws holding the polycord in place on the awning rail.
5. Remove the drive head assembly and idler head assembly retaining bolts from the outer arms to separate the components.
6. Working together, remove the roll tube assembly (which includes the drive/idler head assemblies) from the awning rail and support arms by sliding the assembly along the awning rail until clear.

⚠ WARNING

Failure to support the roll tube, fabric and drive/idler head assemblies during removal may result in serious injury or property damage.

7. Secure the idler head and the roll tube to a work bench.
8. Have someone hold both the roll tube and drive head assembly prior to removing the cotter pin.
9. While one person holds the roll tube, have another person slowly rotate the drive head assembly clockwise to release tension.

⚠ WARNING

Failure to maintain control of the roll tube, fabric and drive/idler head may result in serious injury or property damage.

10. Mark the cam lock position on the roll tube with a non-permanent marker.
11. Remove the three screws holding the drive head assembly end cap on the roll tube and set the drive head assembly aside.

NOTE: Awnings longer than 6' will also have tension that needs to be released in the idler head assembly prior to continuing the procedure. To release tension, remove the idler head cotter pin and slowly rotate the idler head in a counterclockwise motion to release tension in the idler head assembly's spring.

12. Place the roll tube and fabric on a clean, level surface that is free of any debris able to scratch or damage the roll tube and/or fabric.
13. With one person holding the awning rail end of the fabric, another can rotate the roll tube to unroll the fabric until only the polycord is left on the roll tube.
14. Remove the screws holding the polycord in place on the roll tube.
15. Mark the roll tube groove containing the polycord with a non-permanent marker prior to removing the fabric from the roll tube.
16. To remove the fabric, gently pull the roll tube from the idler end, while another person holds the fabric in place.

AWNINGS

Installation

1. Unroll the new fabric onto the old fabric to help keep fabric from getting damaged.
2. On a clean, level surface free of any debris able to scratch or damage the roll tube, gently slide the roll tube onto the polycord of the fabric, making sure that the non-printed side is touching the roll tube (Fig. 4).
3. Center the fabric on the roll tube.
4. Apply the screws that were holding the polycord in place on the roll tube. Install the screws no more than 1/4" from the edge of the fabric.
5. Roll the fabric onto the roll tube (Fig. 5). Make sure the fabric stays snug and flat to the roll tube with the printed side facing away.

Fig. 4

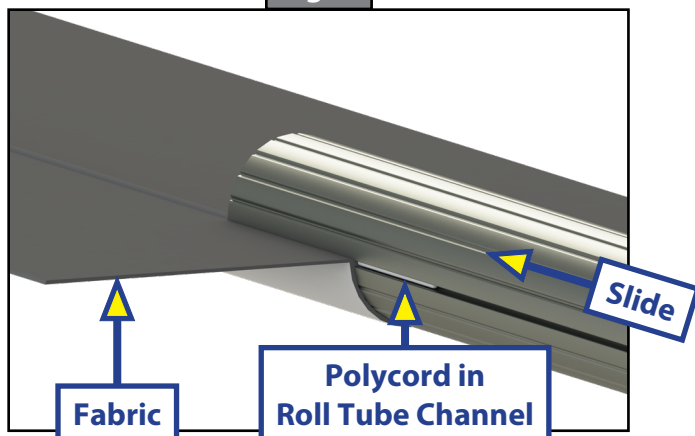
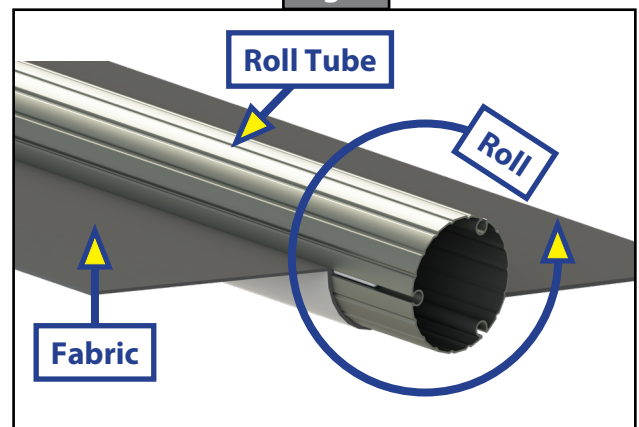

Fig. 5



6. Using the three screws previously removed from the drive head assembly end cap, attach the drive head to the roll tube, making sure the orientation is the same.

NOTE: Be sure the drive head assembly with the cam lock is on the right-hand side of the awning.

7. Secure the idler head and roll tube to the work bench.
8. Rotate the drive head assembly counterclockwise, proper turns according to the length of the awning (Fig. 6) and insert a cotter pin into the end cap into the shaft on the drive head assembly.

NOTE: If the awning is longer than 6' and the idler head assembly tension had previously been released, rotate the idler head assembly clockwise according to the length of the awning (Fig. 6) and insert a cotter pin into the end cap into the shaft on the idler head assembly. Be sure that both head assemblies are parallel once tension has been added.

Fig. 6

| Manual Awning Tensioning | |
|--------------------------|--------------------------------|
| Awning Length | Proper Tensioning (# of turns) |
| 6'* | 15 |
| 7'-16' | 9 |
| 17'-21' | 10 |
| 22'-28' | 11 |

NOTE: *6' Awnings only have one spring to tension on the drive side.

AWNINGS

⚠ WARNING

Failure to support the roll tube, fabric and drive/idler head assembly during installation may result in serious injury or property damage.

9. Working together, install the roll tube assembly (which includes the drive/idler head assemblies) to the awning rail and support arms by sliding the assembly along the awning rail. Make sure the awning fabric unrolls printed side up.
10. Install the previously removed drive/idler head assembly retaining bolts into the outer arms to secure.
NOTE: Make sure the cam lock is in the extended position, otherwise the awning will slam shut causing damage when cotter pins are removed.
11. Remove the cotter pins from both end caps and cut the zip ties from the support arm assemblies.
12. Secure the fabric with to the awning rail using **ONE** of the two options listed below. In option 1 the screw will go through the fabric and polycord, while in option 2, the screw will only go through the polycord.

NOTE: Before securing the fabric, extend and retract the room several times to ensure that the fabric is square on the roll tube.

Option 1

Secure the fabric (Fig. 7A) in the awning rail (Fig. 7B) no more than 1" inside the edge of the fabric on both ends using an OEM supplied #6 x 1/2" hex head screw (Fig. 7C). Install the screw (Fig. 7C) down through the awning rail (Fig. 7B) into the fabric (Fig. 7A) and the polycord (Fig. 7D).

Option 2

Secure the fabric (Fig. 7A) in the awning rail (Fig. 7B) no more than 1/4" outside the edge of the fabric on both ends using an OEM supplied #6 x 1/2" hex head screw (Fig. 7E). Install the screw (Fig. 7E) down through the awning rail (Fig. 7B) and polycord (Fig. 7D).

Fig. 7

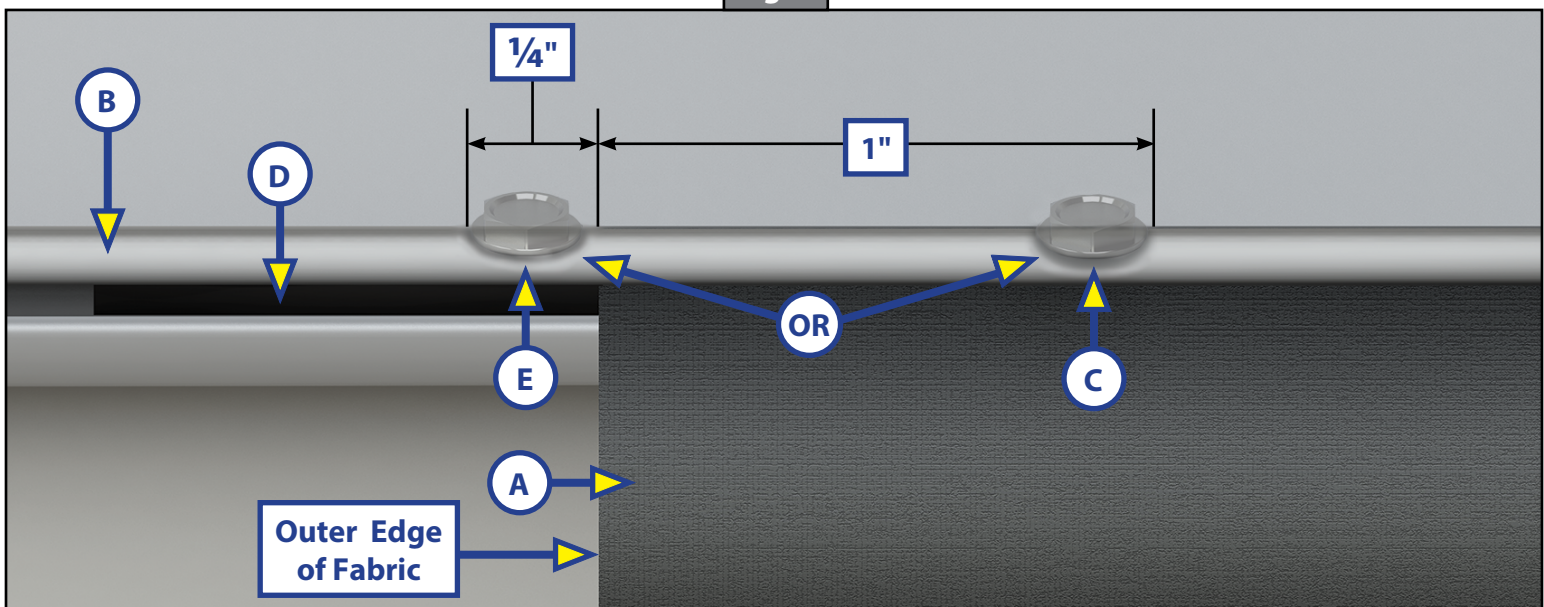

13. Reinstall the drip cap (if previously equipped).

AWNINGS

Power and Hybrid Awning Fabric Replacement

Resources Required

- 1 to 3 People (depending on task)
- Cordless or Electric Drill or Screw Gun
- Appropriate Drive Bits
- Zip Ties

Removal

1. Remove the drip cap (if equipped) from the end from which the fabric will be removed.
2. Fully extend the awning. Under power awning should only extend 8"-12".
3. Disconnect any fabric LED lights in the support arm assembly.
4. Secure both support arm assemblies by running a zip tie around the outer arm and around the pin on the top of the mount arm where the mount arm and inner arm connect (Fig. 8).
5. Remove the screws holding the polycord in place on the awning rail.
6. Remove the wax screws holding the end caps onto the drive and idler head shafts (Fig. 9).
7. Working together, remove the roll tube and fabric from the awning rail and support arm assemblies.
8. Place the roll tube and fabric on a clean, level surface that is free of any debris able to scratch or damage the roll tube and/or fabric.
9. Remove the end cap from the end of the roll tube from which the fabric will be removed.
10. With one person holding the end of the fabric that gets attached to the awning rail on the unit, another can rotate the roll tube to unroll the fabric until only the polycord is left on the roll tube.

Fig. 8



Fig. 9



⚠ WARNING

Failure to support the roll tube, fabric and drive/idler head assembly during installation may result in serious injury or property damage.

NOTE: If single polycord, the end cap does not need to be removed.

11. Remove the screws holding the polycord in place on the roll tube.
12. To remove the fabric, gently pull the roll tube from one end, while another person holds the fabric in place.

AWNINGS

Installation

1. Unroll the replacement fabric so that the cords are parallel with the roll tube.
2. On a clean, level surface free of any debris able to scratch or damage the roll tube, gently slide the roll tube onto the polycord of the fabric, making sure that the non-printed side is touching the roll tube (Fig. 10).
3. Center the fabric on the roll tube.
4. Install the screws that were holding the polycord in place on the roll tube. Install the screws no more than 1/4" from the edge of the fabric.
5. Put new fabric on top of the old fabric. Roll the fabric onto the roll tube (Fig. 11). Make sure the fabric stays snug and flat to the roll tube with the printed side facing away.

Fig. 10

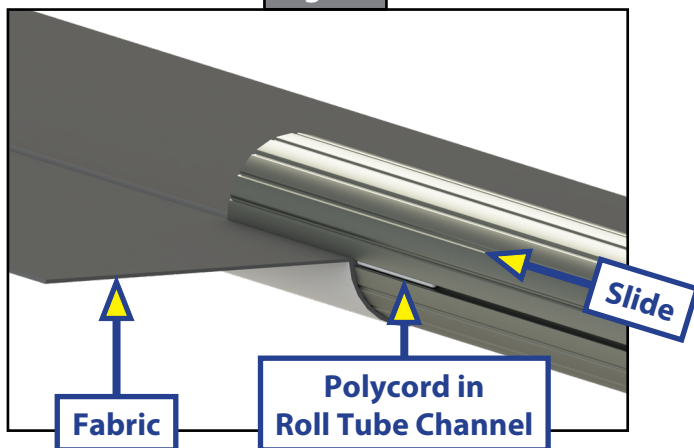
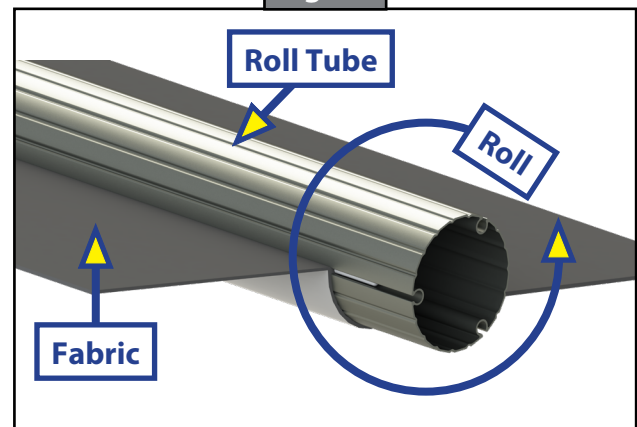

Fig. 11



6. Reinstall the end cap previously removed.
7. Working together, install the roll tube and fabric on the awning rail and support arms, making sure the awning will unroll with the printed side of the fabric up.

⚠ WARNING

Failure to support the roll tube, fabric and drive/idler head assembly during installation may result in serious injury or property damage.

8. Working together, slide the shaft on the head assembly into the end cap. Install the wax screws at each end to secure the roll tube end caps to the head assemblies.

NOTE: It is suggested to keep the head of the wax screw $\frac{1}{8}$ " from fastened so as not to compromise the structural integrity of the wax screw.

9. Remove zip ties, extend and retract the awning several times to ensure that the fabric is square on the rail.

AWNINGS

10. Secure the fabric with to the awning rail using **ONE** of the two options listed below. In option 1 the screw will go through the fabric and polycord, while in option 2, the screw will only go through the polycord.

NOTE: Before securing the fabric, extend and retract the room several times to ensure that the fabric is square on the roll tube.

Option 1

Secure the fabric (Fig. 12A) in the awning rail (Fig. 12B) no more than 1" inside the edge of the fabric on both ends using an OEM supplied #6 x 1/2" hex head screw (Fig. 12C). Install the screw (Fig. 12C) down through the awning rail (Fig. 12B) into the fabric (Fig. 12A) and the polycord (Fig. 12D).

Option 2

Secure the fabric (Fig. 12A) in the awning rail (Fig. 12B) no more than 1/4" outside the edge of the fabric on both ends using an OEM supplied #6 x 1/2" hex head screw (Fig. 12E). Install the screw (Fig. 12E) down through the awning rail (Fig. 12B) and polycord (Fig. 12D).

Fig. 12

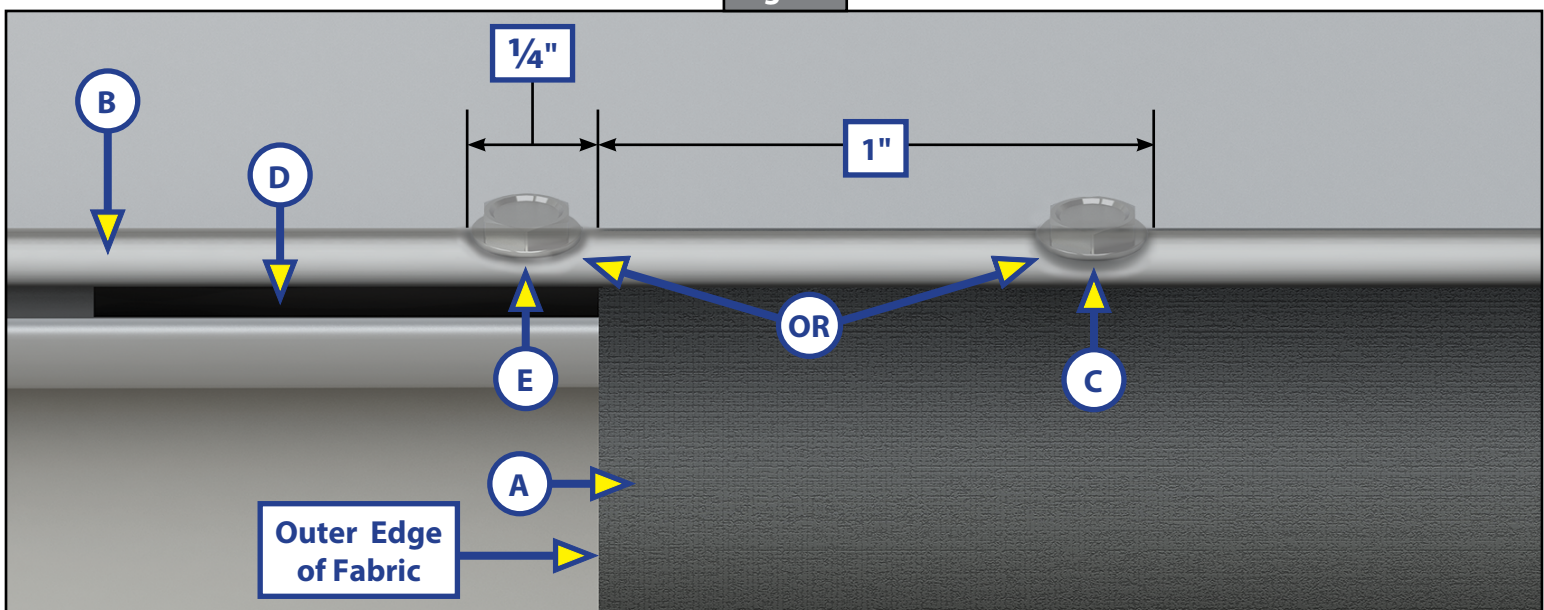

11. Reinstall the drip cap (if previously equipped).
12. Reconnect any light wiring as needed.

NOTE: The fabric LED light strip will need to be installed on the polycord of the fabric prior to connecting any wiring previously removed.