

AWNINGS

⚠ CAUTION

Moving parts can pinch, crush or cut. Keep clear and use caution.

⚠ WARNING

Always wear eye protection when performing service or maintenance to the coach. Other safety equipment to consider includes hearing protection, gloves and possibly a full face shield, depending on the nature of the service.

Removal of the Arm

1. Roll awning out approximately 1 ft.
2. Align the hole in the end cap with the hole in the shaft going from the head through the end cap.
3. Insert a cotter pin through the aligned end cap and head shaft holes on each end of the awning (Fig. 1).
4. Remove the screw holding the support arm to the head on the awning roll tube (Fig. 1).

⚠ CAUTION

Make sure the roll tube is adequately supported before removing the support arm assembly. Failure to do so may result in serious personal injury or property damage.

5. Remove the 2 screws securing the upper mounting bracket to the sidewall of the coach (Fig. 2).
6. Remove the support arm from the head and un-latch it from the bottom bracket (Fig. 3).

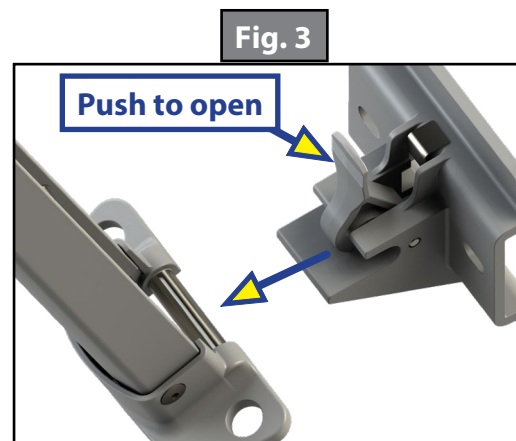
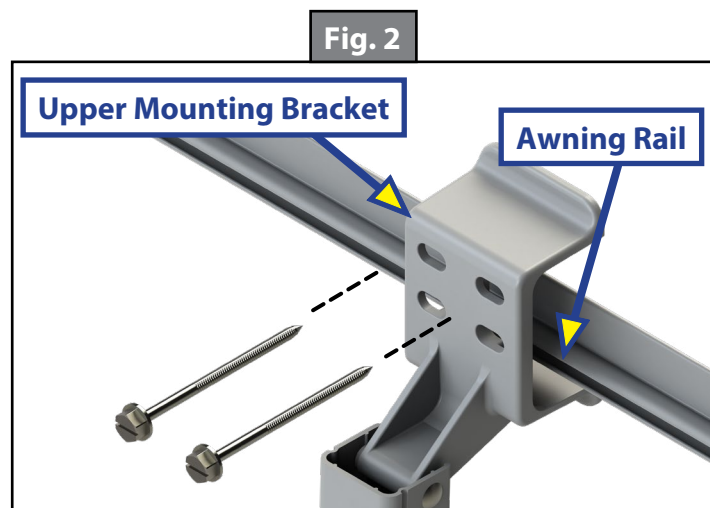
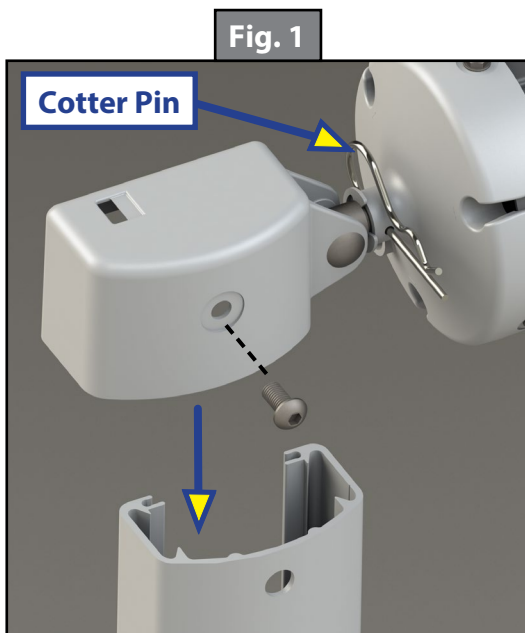

AWNINGS

Installation of the New Arm

1. Secure the support arm assembly in the lower mounting bracket (Fig. 4).
2. Place the upper bracket in place over the awning rail in the same position from which the old bracket was removed. Apply a liberal amount of sealant over the holes and attach the bracket using the ¼" x 3" lag screws provided (Fig. 5).
3. Slide the support arm assembly into the head assembly and secure with the screw that was previously removed (Fig. 6).
4. Ensure the locking lever is still in the roll out position and remove the cotter pin (Fig. 6) from the end cap and head shaft holes.

⚠ CAUTION

Firmly grasp the pull strap on the awning fabric before removing the cotter pins to prevent the awning from retracting on its own. Failure to do this may result in serious personal injury or property damage.

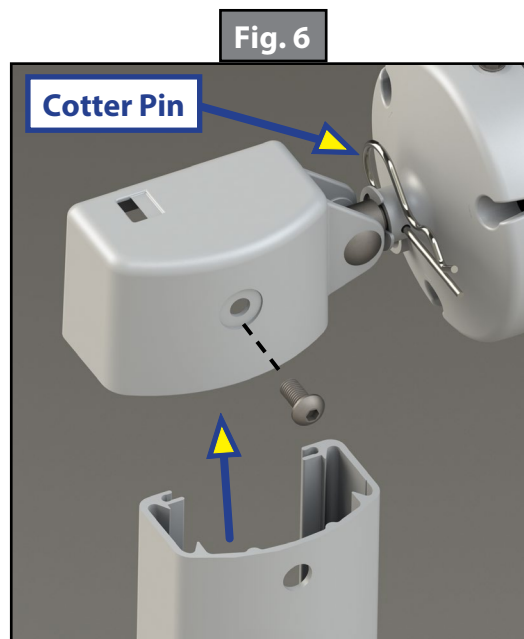
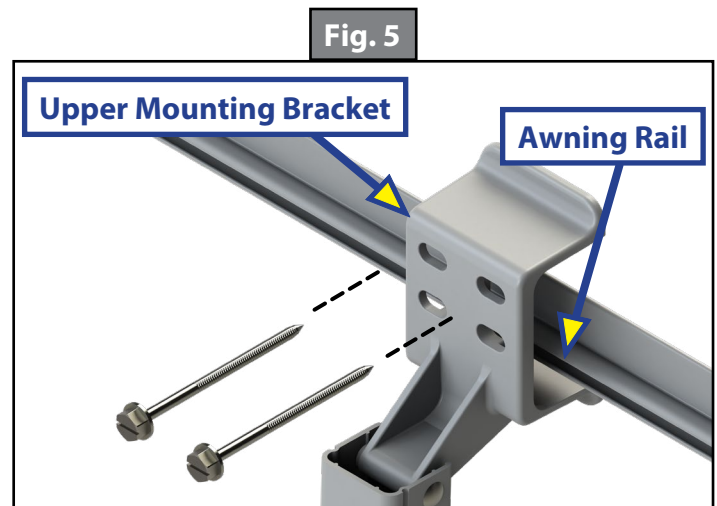
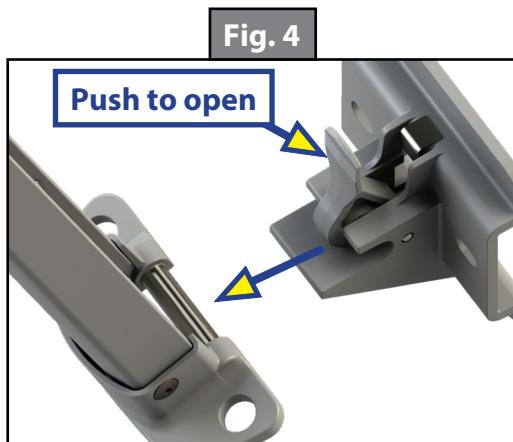

AWNINGS

Installing the Stop Bolt

1. Retract the awning.
2. Make sure the centerline of the roll tube is level with or slightly higher than the centerline of the awning rail. The bottom of the roll tube **MUST NOT** be higher than the awning rail.
3. Adjust support arm if necessary.
 - A. Open the support arm handle and slide the upper arm up or down as required. Close the handle and slide the lower channel until the locking pin clicks into the nearest positioning hole (Fig. 7).

NOTE: May have to flip cam level to extend in order for awning arm to be raised.

4. Mark the position of the stop hole that is directly below the upper channel.
5. From the inside of the channel, insert a $\frac{5}{16}$ " bolt and star washer through the hole. Secure with a $\frac{5}{16}$ " cap nut using $\frac{1}{2}$ " socket and wrench (Fig. 8).

NOTE: It may be necessary to lift the upper channel to tighten the cap nut.

6. Repeat steps 4 and 5 for the other support arm.

