

## WINDOWS

### Purpose

This document outlines the procedure for replacing the top hinge vent for Hehr windows.

### Safety

Read and understand all instructions before installing or operating this product. Adhere to all safety labels.

#### CAUTION

The "CAUTION" symbol above is a sign that a procedure has a safety risk involved and may cause personal injury, product and/or property damage if not performed safely and within the parameters set forth in this document.

#### CAUTION

Use appropriate personal protective equipment (PPE) for the procedure being performed.

#### CAUTION

Moving parts can pinch, crush or cut. Keep clear and use caution.

### Resources Required

- Cordless or electric drill or screw gun
- Phillips drive bit
- 3/16" Drill bit
- 3/32" Drill bit
- Pop rivet gun
- 3/32" Pop rivet
- Ladder



LIPPERT  
COMPONENTS

# TOP HINGE VENT REPLACEMENT FOR HEHR WINDOWS

TI-370

## WINDOWS

### Procedure

1. Remove the screw securing the handle, then remove handle from operator (Fig. 1A). Retain screw and handle for re-installation.
2. Remove the screen by slightly lifting and pulling on the bottom of the screen frame. Once the bottom screen springs are free, continue to slightly pull until the screen is free from the window. Gently remove the screen over operator body (Fig. 1B). Retain for re-installation.

Fig. 1

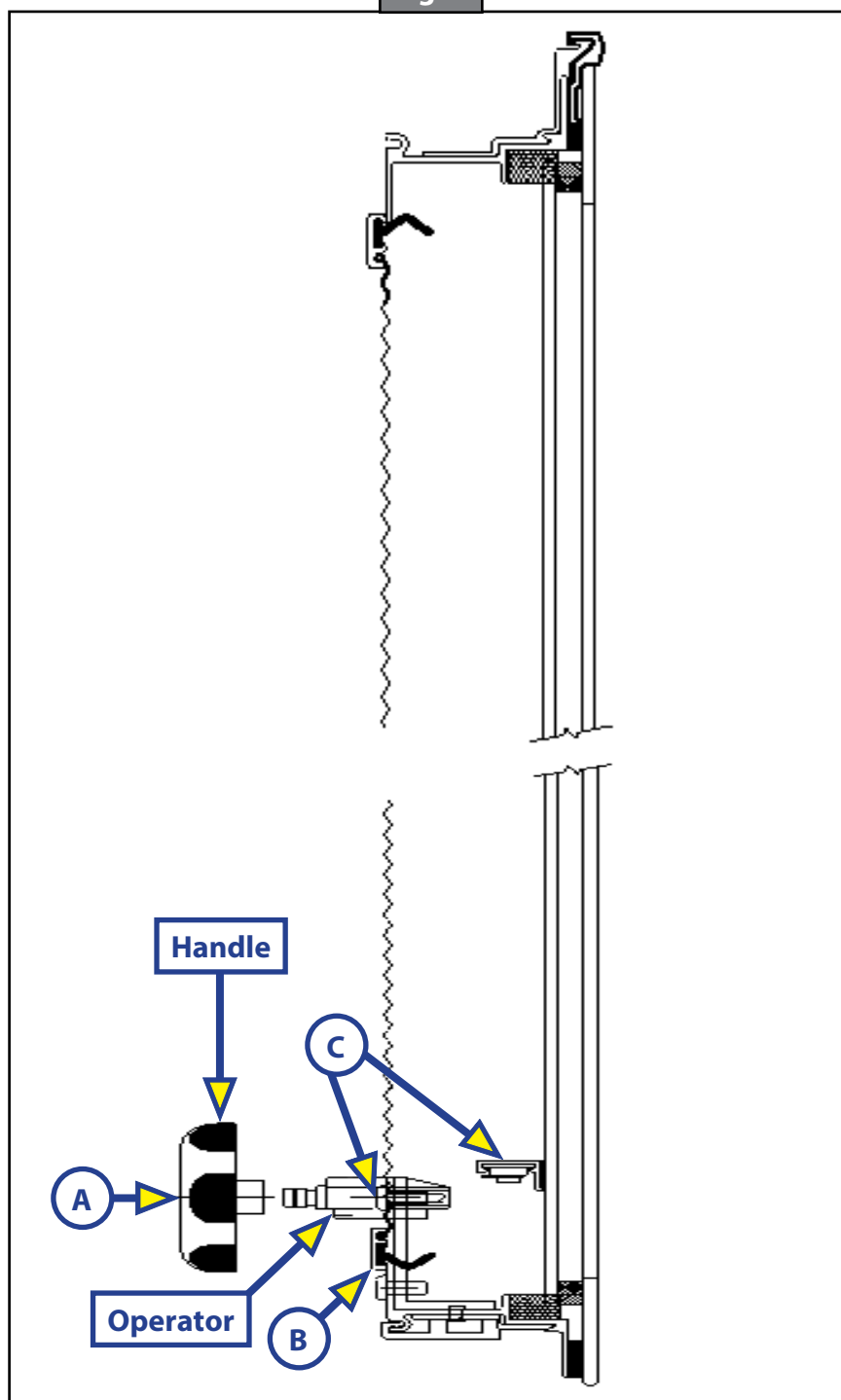



LIPPERT  
COMPONENTS

# TOP HINGE VENT REPLACEMENT FOR HEHR WINDOWS

TI-370

## WINDOWS

3. Remove operator using 3/16" drill bit. Drill out rivets, then lift and push operator from bracket and slide arms from the rail (Fig. 1C). Retain operator for re-installation.
4. Remove vent section by opening the vent section slightly past 90 degrees. Apply forward pressure at 90 degrees and the vent section will disengage and come out (Fig. 2A).
5. Replace the vent section. With the vent section at 90 degrees to the window, install the vent hinge portion into the window hinge (Fig. 2B). Pull slightly until the two hinges interlock then rotate the vent section to the closed position, making sure the glass is centered on the window.

Fig. 2

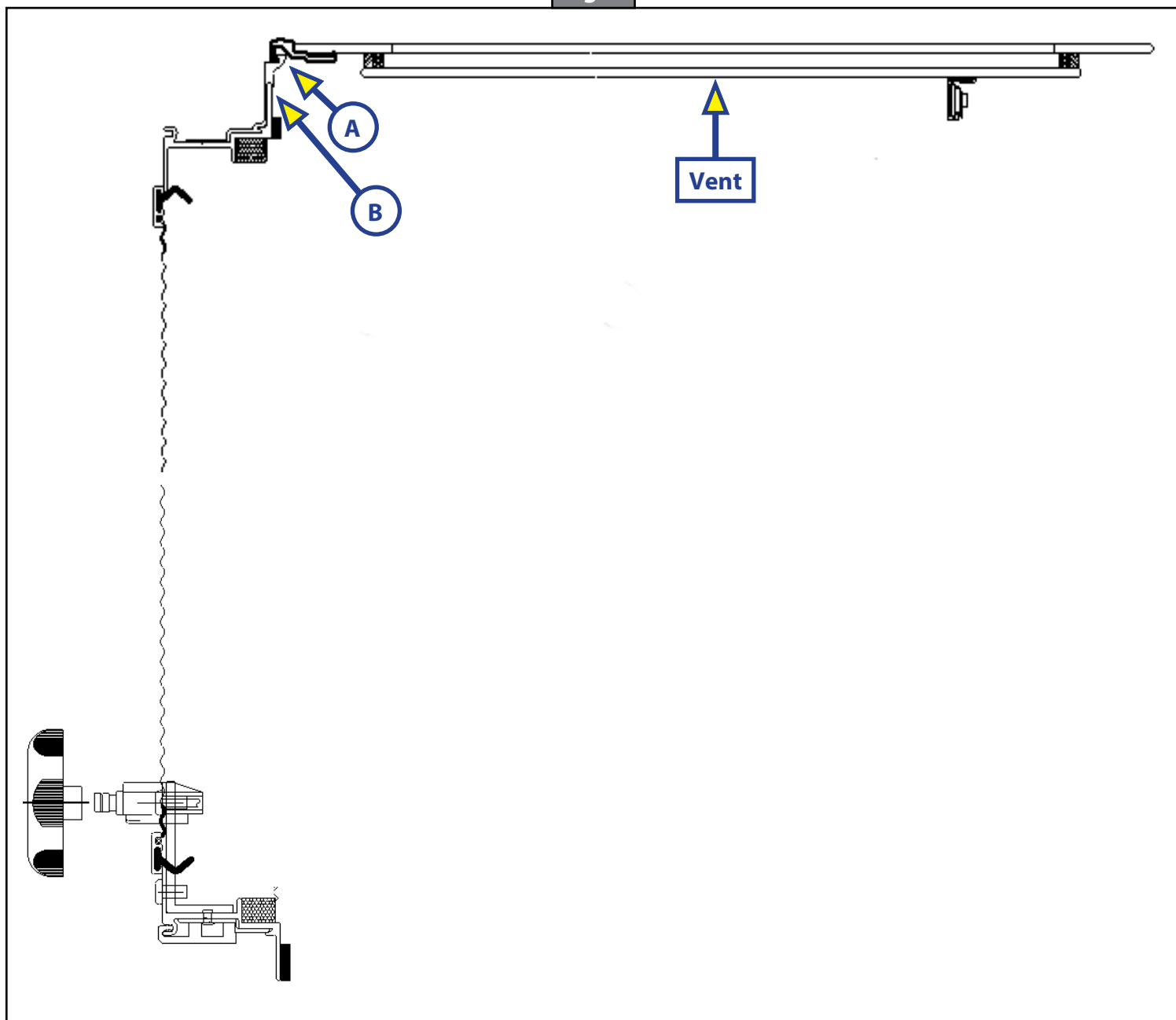



LIPPERT  
COMPONENTS

# TOP HINGE VENT REPLACEMENT FOR HEHR WINDOWS

TI-370

## WINDOWS

6. Install the operator and rivet into place.
7. Install screen.
8. Install handle and secure with screw.
9. Using the existing slots in the window hinge as a guide, drill a  $\frac{3}{32}$ " diameter hole through the window hinge, one on each side (Fig. 3). Remove any burrs from the drilled holes. Insert pop rivet(s) through holes and set.

Fig. 3

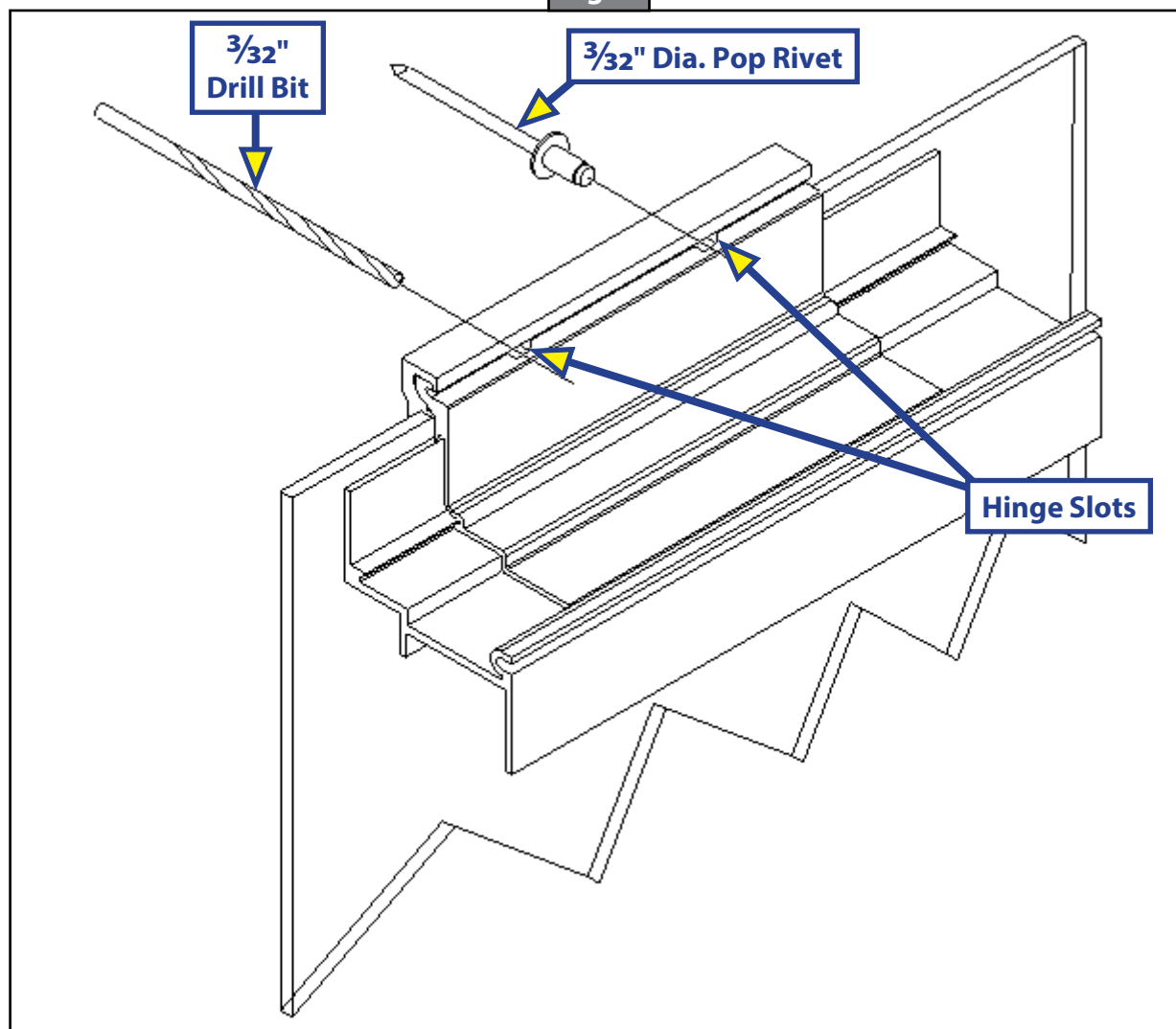

As a supplier of components to the RV industry, safety, education and customer satisfaction are our primary concerns. Should you have any questions, please do not hesitate to contact us at (574) 537-8900 or by email at [customerservice@lci1.com](mailto:customerservice@lci1.com). Self-help tips, technical documents, product videos and a training class schedule are available at [lci1.com](http://lci1.com) or by downloading the MyLCI app.